

2

**RECEIVED**  
 The Minnesota  
**State Register**  
 LEGISLATIVE PRINTING LIBRARY  
 POL. BLDG. 55155

Department of Administration—Print Communications Division

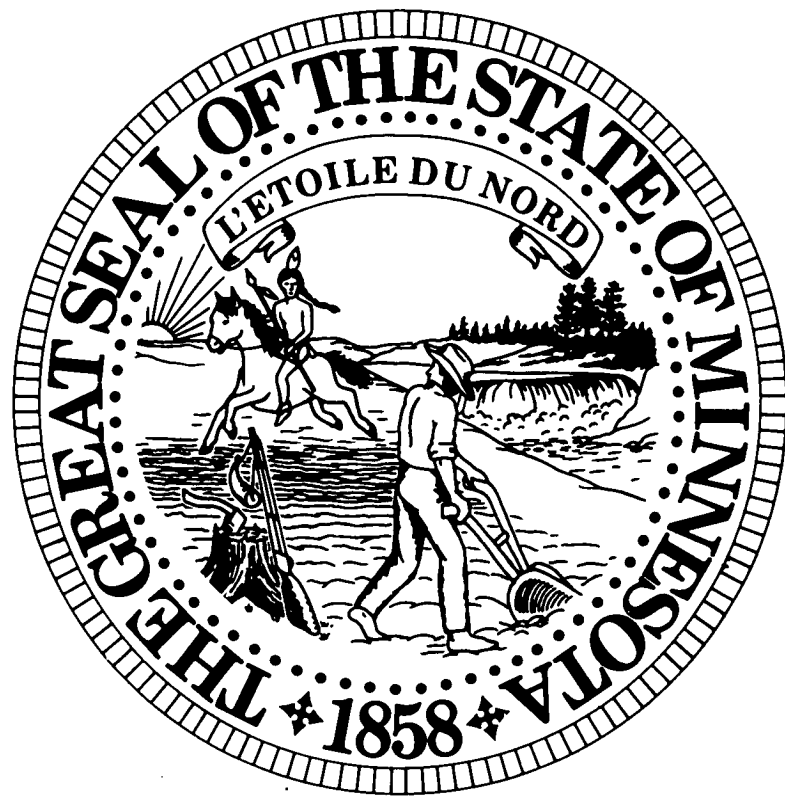

Rules edition  
 Published every Monday  
 (Tuesday if Monday is a holiday)

**Monday 20 April 1992**  
**Volume 16, Number 43**  
**Pages 2269-2360**

# State Register

## Judicial Notice Shall Be Taken of Material Published in the *State Register*

The *State Register* is the official publication of the State of Minnesota, containing executive and commissioners' orders, proposed and adopted rules, official and revenue notices, state and non-state contracts, contract awards, grants, a monthly calendar of cases to be heard by the state supreme court, and announcements.

A *Contracts Supplement* is published every Thursday and contains additional state contracts and advertised bids, and the most complete source of state contract awards available in one source.

### Printing Schedule and Submission Deadlines

| Vol. 16<br>Issue<br>Number | *Submission deadline for<br>Adopted and Proposed Rules,<br>Commissioners' Orders** | *Submission deadline for<br>Executive Orders, Contracts,<br>and Official Notices** | Issue<br>Date   |
|----------------------------|--|--|-----------------|
| 43                         | Monday 6 April   | Monday 13 April  | Monday 20 April |
| 44                         | Monday 13 April  | Monday 20 April  | Monday 27 April |
| 45                         | Monday 20 April  | Monday 27 April  | Monday 4 May    |
| 46                         | Monday 27 April  | Monday 4 May   | Monday 11 May   |

\*Deadline extensions may be possible at the editor's discretion; however, none will be made beyond the second Wednesday (12 calendar days) preceding the issue date for rules, proposed rules and executive orders, or beyond the Wednesday (5 calendar days) preceding the issue date for official notices. Requests for deadline extensions should be made only in valid emergency situations.

\*\*Notices of public hearings on proposed rules and notices of intent to adopt rules without a public hearing are published in the Proposed Rules section and must be submitted two weeks prior to the issue date.

Instructions for submission of documents may be obtained from the *State Register* editorial offices, 504 Rice Street, St. Paul, Minnesota 55103, (612) 296-4273.

The *State Register* is published every Monday (Tuesday when Monday is a holiday) by the State of Minnesota, Department of Administration, Print Communications Division, 117 University Avenue, St. Paul, Minnesota 55155, pursuant to *Minnesota Statutes* § 14.46. A *State Register Contracts Supplement* is published every Thursday. The Monday edition is the vehicle for conveying all information about state agency rulemaking, including official notices; hearing notices; proposed, adopted and emergency rules. It also contains executive orders of the governor; commissioners' orders; state contracts and advertised bids; professional, technical and consulting contracts; non-state public contracts; state grants; decisions of the supreme court; a monthly calendar of scheduled cases before the supreme court; and other announcements. The Thursday edition contains additional state contracts and advertised bids, and the most complete listing of contract awards available in one source.

In accordance with expressed legislative intent that the *State Register* be self-supporting, the following subscription rates have been established: the Monday edition costs \$140.00 per year and includes an index issue published in August (single issues are available at the address listed above for \$3.50 per copy); the combined Monday and Thursday editions cost \$195.00 (subscriptions are not available for just the *Contracts Supplement*); trial subscriptions are available for \$60.00, include both the Monday and Thursday edition, last for 13 weeks, and may be converted to a full subscription anytime by making up the price difference. No refunds will be made in the event of subscription cancellation.

Both editions are delivered postpaid to points in the United States, second class postage paid for the Monday edition at St. Paul, MN, first class for the Thursday edition. Publication Number 326630 (ISSN 0146-7751).

Subscribers who do not receive a copy of an issue should notify the *State Register* circulation manager immediately at (612) 296-0931. Copies of back issues may not be available more than two weeks after publication.

**Arne H. Carlson, Governor**  
**Dana B. Badgerow, Commissioner**  
Department of Administration

**Stephen A. Ordahl, Director**  
Print Communications Division  
Paul Hoffman, Acting Editor

**Katherine J. Artishon, Assistant Editor**  
**Debbie George, Circulation Manager**  
**Bonita Karels, Staff Assistant**

## FOR LEGISLATIVE NEWS

Publications containing news and information from the Minnesota Senate and House of Representatives are available free to concerned citizens and the news media. To be placed on the mailing list, write or call the offices listed below:

### SENATE

**Briefly-Preview**—Senate news and committee calendar; published weekly during legislative sessions.

**Perspectives**—Publication about the Senate.

**Session Review**—Summarizes actions of the Minnesota Senate.

Contact: Senate Public Information Office  
Room 231 State Capitol, St. Paul, MN 55155  
(612) 296-0504

### HOUSE

**Session Weekly**—House committees, committee assignments of individual representatives; news on committee meetings and action. House action and bill introductions

**This Week**—weekly interim bulletin of the House.

**Session Summary**—Summarizes all bills that both the Minnesota House of Representatives and Minnesota Senate passed during their regular and special sessions.

Contact: House Information Office  
Room 175 State Office Building, St. Paul, MN 55155  
(612) 296-2146

# Contents

## Minnesota Rules: Amendments & Additions

Issues 40-43 inclusive (issues # 1-39 appeared in # 39) . . . . . 2272

### Proposed Rules

#### Labor & Industry Department

Ammonia refrigeration systems . . . . . 2273

#### Pollution Control Agency

Nonstandard engines; automobile emission standards . . . 2307

#### Transportation Department

Port development assistance program . . . . . 2309

### Adopted Rules

#### Dentistry Board

Licensure . . . . . 2314

#### Health Department

Eligible analytes under the clean water and safe drinking water program . . . . . 2317

#### Jobs and Training Department

Designation and recognition of community action agencies and granting of funds for community action programs . . . . . 2319

#### Pollution Control Agency

Hazardous waste . . . . . 2321  
Ash management . . . . . 2321

### Executive Orders

#### Executive Department

Executive Order 92-5: Providing for administration of technology related assistance for individuals with disabilities . . . . . 2327

### Commissioner's Orders

#### Natural Resources Department

Order No. 2439: Regulations for the taking of bear during 1992 . . . . . 2329

### Revenue Notices

Notice #92-12: Sales and use tax—lawn, garden, and arborist services and landscaping contracts . . . . 2334

### Official Notices

#### Minnesota Comprehensive Health Association

Special meeting of the board of directors . . . . . 2334  
Meeting of nominating committee . . . . . 2334

#### Education Department

Hearing . . . . . 2335

#### Ombudsman for Mental Health and Mental Retardation Office

Meeting of advisory committee . . . . . 2335

#### Revenue Department

Outside opinions sought regarding proposed rules governing sale and use of admissions and the use of amusement services . . . . . 2335

#### Minnesota Rural Finance Authority

Public hearings on the issuance of agricultural development bonds in:  
Blue Earth County . . . . . 2336  
Olmsted County . . . . . 2336  
Winona County—\$50,000 . . . . . 2336  
Winona County—\$100,000 . . . . . 2337  
Swift County . . . . . 2337  
Big Stone County . . . . . 2337

#### Secretary of State

Vacancies in multi-member agencies . . . . . 2338

## State Grants

### Corrections Department

Funds available for pilot program for the treatment of sex offenders . . . . . 2339

### Human Services Department

Grant monies available for American Indian adolescent aftercare . . . . . 2340

## Professional, Technical & Consulting Contracts

### Administration Department

Proposals sought for professional computer services . . . . 2340

### Finance Department

Request for information on software packages for statewide systems supporting accounting, human resources, payroll and purchasing . . . . . 2340

### Human Services Department

Proposals sought for chemical dependency treatment outcome follow-up interviews . . . . . 2341  
Proposals sought to analyze rate-setting systems for ICFs/MR . . . . . 2341  
Proposals sought for an independent assessment of the community alternatives for independent living waiver program . . . . . 2342  
Proposals sought for services of a psychiatrist . . . . . 2342

### Minnesota State Lottery

Bids sought for printed T-shirts . . . . . 2342

### Pollution Control Agency

Proposals sought for toxicity tests of storm water entering Miller Creek, Duluth . . . . . 2343  
Proposals sought to develop a public awareness campaign in the Lake Superior Basin . . . . . 2344

### Revenue Department

Professional services sought . . . . . 2345

### Trade and Economic Development Department

Professional development training services sought . . . . 2345

### Transportation Department

Proposals sought for succession planning . . . . . 2348

### Water & Soil Resources Board

Services sought for sinkhole treatment project design consultant . . . . . 2349

## Non-State Public Contracts

### Minnesota Historical Society

Proposals sought for restoration services for a bronze statue . . . . . 2349  
Proposals sought for page printing services . . . . . 2350  
Proposals sought for provision of store fixtures . . . . . 2350  
Proposals sought for general construction for museum stores . . . . . 2350  
Proposals sought for fund-accounting computer software . . . . . 2350  
Proposals sought for provision of computer hardware . . . 2350  
Proposals sought for manufacture of a book . . . . . 2351

### Lower Minnesota River Watershed District

Request for interest proposals for legal consultant services . . . . . 2351

### Metropolitan Waste Control Commission

Proposals sought for professional services for an employee assistance program . . . . . 2351

## State Contracts & Advertised Bids

### Administration Department

**Materials Management Division:** Commodities and requisitions open for bid . . . . . 2352  
**Print Communications Division:** Typesetting, keylining, photo prep and seps, printing, binding, labeling and mailing contracts open for bid . . . . . 2355

# Minnesota Rules: Amendments and Additions

## NOTICE: How to Follow State Agency Rulemaking in the State Register

The *State Register* is the official source, and only complete listing, for all state agency rulemaking in its various stages. State agencies are required to publish notice of their rulemaking action in the *State Register*. Published every Monday, the *State Register* makes it easy to follow and participate in the important rulemaking process. Approximately 75 state agencies have the authority to issue rules. Each agency is assigned specific *Minnesota Rule* chapter numbers. Every odd-numbered year the *Minnesota Rules* are published. This is a ten-volume bound collection of all adopted rules in effect at the time. Supplements are published to update this set of rules. Proposed and adopted emergency rules do not appear in this set because of their short-term nature, but are published in the *State Register*.

If an agency seeks outside opinion before issuing new rules or rule amendments, it must publish a NOTICE OF INTENT TO SOLICIT OUTSIDE OPINION in the *Official Notices* section of the *State Register*. When rules are first drafted, state agencies publish them as **Proposed Rules**, along with a notice of hearing, or notice of intent to adopt rules without a hearing in the case of noncontroversial rules. This notice asks for comment on the rules as proposed. Proposed emergency rules and withdrawn proposed rules are also published in the *State Register*. After proposed rules have gone through the comment period, and have been rewritten into their final form, they again appear in the *State Register* as **Adopted Rules**. These final adopted rules are not printed in their entirety in the *State Register*, only the changes made since their publication as Proposed Rules. To see the full rule, as adopted and in effect, a person simply needs two issues of the *State Register*, the issue the rule appeared in as proposed, and later as adopted. For a more detailed description of the rulemaking process, see the *Minnesota Guidebook to State Agency Services*.

The *State Register* features partial and cumulative listings of rules in this section on the following schedule: issues 1-13 inclusive; issues 14-25 inclusive; issue 26, cumulative for issues 1-26; issues 27-38 inclusive; issue 39, cumulative for 1-39; issues 40-51 inclusive; and issue 52, cumulative for 1-52. An annual subject matter index for rules appears in August. For copies of the *State Register*, a subscription, the annual index, the *Minnesota Rules* or the *Minnesota Guidebook to State Agency Services*, contact the Print Communications Division, 117 University Avenue, St. Paul, MN 55155 (612) 297-3000 or toll-free in Minnesota 1-800-9747.

|  |   |      |
|--|---|------|
| Issues 40-43 inclusive (issues #1-39 appeared in #39)          | 7005.5030 (proposed) . . . . .                                  | 2307 |
| <b>Architecture, Engineering, Land Surveying and Landscape</b> | 7105.0060; .0090 (adopted) . . . . .                            | 2207 |
| <b>Architecture Board</b>                                      | 7151.0010; .0020; .0030; .0040; .0050; .0060; .0070;            |      |
| 1800.0500 (proposed) . . . . .                                 | .0080; .0090; .0100; .0110; .0120; .0130; .0140; .0150;         |      |
| 2233   | .0160; .0170; .0180; .0190; .0200; .0210; .0220; .0230;         |      |
| <b>Dentistry Board</b>   | .0240 (withdrawn) . . . . .                                     | 2166 |
| 3100.0100; .1100; .1200; .3600; .6200; .6300; .8500;           | 7100.0010; .0020; .0030; .0040; .0050; .0060; .0070;            |      |
| .8700 (adopted) . . . . .                                      | .0080; .0090 (proposed repealer withdrawn) . . . . .            | 2166 |
| 2314   |   |      |
| <b>Jobs and Training Department</b>                            | <b>Harmful Substance Compensation Board</b>                     |      |
| 3350.0010; .0020; .0030; .0040; .0050; .0060; .0070;           | 7190.1100; .1110; .1120; .1130; .1140; .1150; .1160;            |      |
| .0080; .0090; .0100; .0110; .0120; .0130; .0140; .0150;        | .1170; .1180; .1190; .2000; .2010 (adopted) . . . . .           | 2162 |
| .0160; .0170; .0180; .0190; .0200 (adopted) . . . . .          |   |      |
| 2319   | <b>Public Safety Department</b>                                 |      |
| <b>Technical Colleges Board</b>                                | 7450.0100; .0200; .0250; .0300; .0400; .0430; .0460;            |      |
| 3700.0465; .0850 (adopted) . . . . .                           | .0600; .0700; .0800 (adopted) . . . . .                         | 2246 |
| 2207   | 7450.0900 (repealed) . . . . .                                  | 2246 |
| 3700.1420 (adopted) . . . . .                                  |   |      |
| 2207   | <b>Public Utilities Commission</b>                              |      |
| <b>Electricity Board</b>                                       | 7810.8100; .8200; .8300; .8400; .8500; .8600; .8605;            |      |
| 3800.3520; .3620 (proposed) . . . . .                          | .8610; .8615; .8620; .8625; .8630; .8635; .8640; .8645;         |      |
| 2236   | .8650; .8655; .8660; .8665; .8670; .8675; .8680; .8685;         |      |
| <b>Health Department</b>                                       | .8690; .8700; .8705; .8710; .8715; .8720; .8725; .8730;         |      |
| 4690.4600 (adopted) . . . . .                                  | .8735; .8740; .8745; .8750; .8755; .8760; .8800; .8805;         |      |
| 2207   | .8810; .8815; .8900; .8905; .8910; .8915; .8920; .8925;         |      |
| 4690.4600 s. 7, 8, and 9 (repealed August 1, 1994) . . . . .   | .8930; .8935; .8940 (adopted) . . . . .                         | 2163 |
| 2207   |   |      |
| 4740.2040 (adopted) . . . . .                                  | <b>Water and Soil Resources Board</b>                           |      |
| 2317   | 8410.0010; .0020; .0030; .0040; .0050; .0060; .0070;            |      |
| <b>Higher Education Coordinating Board</b>                     | .0080; .0090; .0100; .0110; .0120; .0130; .0140; .0150;         |      |
| 4810.3030 (adopted) . . . . .                                  | .0160; .0170; .0180 (proposed) . . . . .                        | 2193 |
| 2162   |   |      |
| 4810.3030 s.2 (repealed) . . . . .                             | <b>Minnesota Racing Commission</b>                              |      |
| 2162   | 7890.0100; .0130; .0140; .0150; .0160; 7892.0120                |      |
| <b>Labor &amp; Industry Department</b>                         | (adopted) . . . . .   | 2207 |
| 5230.5000; .5010; .5015; .5020; .5025; .5250; .5300;           | <b>Teaching Board</b>   |      |
| .5350; .5400; .5605; .5610; .5615; .5620; .5625; .5630;        | 8700.5505 (adopted) . . . . .                                   | 2165 |
| .5635; .5640; .5645; .5650; .5655; .5660; .5665; .5675;        | <b>Transportation Department</b>                                |      |
| .5680; .5690; .5700; .5705; .5710; .5820; .5825; .5915;        | 8840.5100; .5300; .5400; .5500; .5600; .5650; .5700;            |      |
| .5925; .5930; .5935; .5940; .5945; .5660; .5950; .6100;        | .5800; .5900; .5910; .5925; .5940; .5950; .5975; .6000;         |      |
| .6110; .6115; .6120; .6125; .6130; .6200 (proposed) . . . . .  | .6100; .6200; .6300 (proposed) . . . . .                        | 2145 |
| 2273   | 8840.5200; .5700 s.3 (proposed repealer) . . . . .              | 2162 |
| <b>Pharmacy Board</b>  | 8895.0100; .0200; .0300; .0400; .0500; .0600; .0700;            |      |
| 6800.1150; .1250; .1300 (adopted) . . . . .                    | .0800; .0900; .1000; .1100 (proposed) . . . . .                 | 2309 |
| 2239   |   |      |
| <b>Pollution Control Agency</b>                                | <b>Human Services Department</b>                                |      |
| 7001.0040; .3050; .3075; .3275; .3300; .3480; 7035.0300;       | 9525.1800; .1810; .1820; .1830; .1840; .1850; .1860;            |      |
| .0400; .0600; .0605; .0700; .0800; .2525; .2535; .2545;        | .1870; .1880; .1890; .1900; .1910; .1920; .2010 (adopted) . . . | 2238 |
| .2555; .2575; .2585; .2625; .2635; .2645; .2655; .2665;        | 9525.1800 s.4, 16, and 19; .1860 s.2 and 5; .1930 s.2           |      |
| .2910; .2915 (adopted) . . . . .                               | (repealed) . . . . .  | 2238 |
| 2321   |   |      |
| 7001.0520; .0650; 7045.0020; .0075; .0131; .0135;              |   |      |
| .0139; .0214; .0292; .0458; .0478; .0532; .0534; .0536;        |   |      |
| .0538; .0552; .0564; .0584; .0630; .0632; .0634; .0638;        |   |      |
| .0665; .1300; .1305; .1308; .1309; .1310; .1315; .1320;        |   |      |
| .1325; .1330; .1333; .1334; .1335; .1339; .1350; .1355;        |   |      |
| .1358; .1360; .1380 (adopted) . . . . .                        |   |      |
| 2239   |   |      |



## Proposed Rules

Pursuant to Minn. Stat. §§ 14.22, an agency may propose to adopt, amend, suspend or repeal rules without first holding a public hearing, as long as the agency determines that the rules will be noncontroversial in nature. The agency must first publish a notice of intent to adopt rules without a public hearing, together with the proposed rules, in the *State Register*. The notice must advise the public:

1. that they have 30 days in which to submit comment on the proposed rules;
2. that no public hearing will be held unless 25 or more persons make a written request for a hearing within the 30-day comment period;
3. of the manner in which persons shall request a hearing on the proposed rules; and
4. that the rule may be modified if the modifications are supported by the data and views submitted.

If, during the 30-day comment period, 25 or more persons submit to the agency a written request for a hearing of the proposed rules, the agency must proceed under the provisions of §§ 14.14-14.20, which state that if an agency decides to hold a public hearing, it must publish a notice of intent in the *State Register*.

Pursuant to Minn. Stat. §§ 14.29 and 14.30, agencies may propose emergency rules under certain circumstances. Proposed emergency rules are published in the *State Register* and, for at least 25 days thereafter, interested persons may submit data and views in writing to the proposing agency.

## Department of Labor and Industry

### Proposed Permanent Rules Relating to Ammonia Refrigeration Systems

#### Notice of Intent to Adopt Rules Without Public Hearing; Notice of Public Hearing on the Proposed Rules if 25 or More Persons Request a Hearing, and Notice of Intent to Cancel the Hearing if Fewer than 25 Persons Request a Hearing

##### I. Explanation of Alternative Notices

The Minnesota Department of Labor and Industry ("Department") hereby gives notice of its intent to adopt rules without public hearing under the noncontroversial rulemaking procedures of *Minnesota Statutes* §§ 14.22 to 14.28 (1990). However, if 25 or more persons request a hearing within 30 days after publication of this Notice in the *State Register*, thus necessitating that one be held, the Department is at the same time giving notice of hearing on the proposed rules pursuant to *Minnesota Statutes* §§ 14.131 to 14.20 (1990). The hearing on the proposed rules, scheduled to commence on June 3, 1992, will be cancelled if within 30 days after publication of this notice, 25 or more people do not request that one be held. To verify whether a hearing will be held, please call B. James Berg on or after May 21, 1992 at the Department at (612) 297-1727.

##### II. Description and Free Copy of the Rules:

#### NOTICES OF: The Statement of Need and Reasonableness; The Impact on Local Public Bodies, The Impact on Small Business, and The Impact on Agricultural Land.

The statutory authority to adopt the rules is *Minnesota Statutes* § 326.46 (1990). The rules proposed for adoption relate to the following matters: The rules establish minimum standards for ammonia piping systems used for closed circuit refrigeration systems, including classifications and standards based on occupancy, type and size of system, maximum quantity of ammonia refrigerant, and type of machinery room. The rules also set standards for air cooled condensers; evaporative shell and tube condensers; pressure vessels; evaporators; refrigerant pumps; refrigeration control valves; sensing devices; pressure relief and protection devices; construction material for piping, valves and fittings; building structure and machine room design; ventilation; electrical; plumbing; lighting and fire safety standards; welding standards; stop valves; piping joints; hangars and support; installation, foundation and support requirements; signs for piping systems; storage, handling and transfer of ammonia; masks and helmets; system responsibility assignment. The rule requires testing, including but not limited to ultimate strength, impact, design pressure, welding, witness, leak, and pressure testing and declaration of testing.

The proposed rules follow this Notice in the *State Register*.

A free copy of the rules is available upon request from B. James Berg, Director, Code Administration and Inspection Services, Department of Labor and Industry, at (612) 297-1727 or 443 Lafayette Road, St. Paul, Minnesota, 55155-4304.

**NOTICE IS HEREBY GIVEN** that a **Statement of Need and Reasonableness** is now available for review at the Department of Labor and Industry and at the Office of Administrative Hearings. The Statement of Need and Reasonableness includes a summary of the evidence and argument which the Department anticipates presenting at the hearing justifying both the need for and reasonableness

**KEY: PROPOSED RULES SECTION** — Underlining indicates additions to existing rule language. ~~Strike outs~~ indicate deletions from existing rule language. If a proposed rule is totally new, it is designated "all new material." **ADOPTED RULES SECTION** — Underlining indicates additions to proposed rule language. ~~Strike outs~~ indicate deletions from proposed rule language.

## Proposed Rules

---

of the proposed rules. Copies of the Statement of Need and Reasonableness may reviewed at the agency or at the Office of Administrative Hearings and copies may be obtained from the Office of Administrative Hearings at the cost of reproduction. Copies may also be obtained from B. James Berg at the Department of Labor and Industry, at the above phone number and address.

### FURTHER NOTICE IS GIVEN THAT:

1. The Department has determined that no fiscal note is necessary under M.S. 14.11 (1990) because the promulgation of these rules is not expected to require local public bodies to expend more than \$100,000 in either of the two years following adoption.

2. The rules may have an impact on small business contractors who install ammonia systems in terms of increased regulation. However, any costs arising from additional regulation should be offset by the uniformity the regulation brings to the marketplace, which will allow contractors to bid and install ammonia systems to a single mandatory statewide standard. Pursuant to *Minnesota Statutes* § 14.115 (1990) the Department has considered methods to reduce the impact on small business. As the rules establish minimum safety standards, it is not appropriate to modify those standards for small business contractors. This is discussed more fully in the Statement of Need and Reasonableness.

3. No impact on agricultural land is expected.

### III. Notice of Intent to Adopt Rules Without a Public Hearing

Notice is hereby given that the State Department of Labor and Industry intends to adopt the above-entitled rules described in Part II without a public hearing following the procedures set forth in the Administrative Procedure Act for adopting rules without a public hearing in *Minnesota Statutes*, sections 14.22 to 14.28.

All persons have 30 days from the date the rules and this notice is published in the *State Register* in which to submit comment in support of or in opposition to the proposed rules or any part or subpart of the rules. Public comment is encouraged. Each comment should identify the portion of the proposed rules addressed, the reason for the comment, and any change proposed.

In addition to submitting comments, any person may request in writing a public hearing on the rules within the 30-day comment period. **If 25 or more persons submit a written request for a public hearing within the 30-day comment period, a public hearing will commence on June 3, 1992, in accordance with *Minnesota Statutes*, sections 14.131-14.20 and the Hearing Notice in Part IV unless a sufficient number withdraw their request in writing.** Any person requesting a public hearing should state his or her name and address, and is encouraged to identify the portion of the proposed rules to be addressed at the hearing, the reason for the request, and any change proposed.

Comments or written requests for a public hearing must be submitted to:

B. James Berg  
Minnesota Department of Labor and Industry  
Code Administration and Inspection Services  
443 Lafayette Road  
St. Paul, Minnesota 55155-4304

The proposed rules may be modified if the modifications are supported by data and views submitted to the agency and do not result in a substantial change in the proposed rules as noticed.

If no hearing is required, upon adoption of the rules, the rules as proposed, the **Statement of Need and Reasonableness**, all written comments, the rules as adopted and a statement explaining any differences between the rules as proposed and as adopted will be submitted to the Attorney General for review as to legality and form, including the issue of substantial change. Any person may request notification of the date of submission to the Attorney General. Persons who wish to be advised of the submission of this material to the Attorney General, or who wish to receive a copy of the adopted rules, must submit the written request to B. James Berg at the above address.

### IV. Notice of Intent to Adopt Rules with a Public Hearing if 25 or More Persons Request a Hearing.

**NOTICE IS HEREBY GIVEN** that the Minnesota Department of Labor and Industry will hold a public hearing on the rules described in Part II in Room 200, State Office Building, 100 Constitution Avenue, St. Paul, Minnesota, commencing at 9:00 a.m. on June 3, 1992. The hearing will continue on that day and, if necessary, on June 4 and 5, 1992 at the same time and location until all interested persons and groups have had an opportunity to be heard concerning the proposed rules. The proposed rules may be modified as a result of the hearing process. You are encouraged to participate if you are in any way affected by these rules. **The hearing will be cancelled if fewer than 25 persons request a hearing in response to the rulemaking notice in Part III.**

If a hearing is required, the matter will be heard before Administrative Law Judge Peter C. Erickson. The rules hearing procedure is governed by *Minnesota Statutes* §§ 14.131 to 14.20 (1990) and by the rules of the Office of Administrative Hearings, *Minnesota Rules* parts 1400.0200 to 1400.1200 (1991). Questions concerning the rules hearing procedure should be directed to the Administrative Law Judge at the Office of Administrative Hearings, 500 Flour Exchange Building, 310 Fourth Avenue South, Minneapolis, Minnesota, 55415, (612) 341-7606.

In addition to submitting comments to the Department during the 30-day period following publication of this notice, any interested person or group may present views on the proposed rules in one or more of the following ways: by submitting written data to the Administrative Law Judge at any time before the close of the hearing; by submitting oral or written data at the hearing; and by submitting written data to the Administrative Law Judge during the comment period following the hearing.

Statements may be submitted without appearing at the hearing. Written material may be submitted and recorded in the hearing record for five working days after the public hearing ends. This comment period may be extended for a longer period not to exceed 20 calendar days if ordered by the Administrative Law Judge at the hearing. The written material received during the comment period after the hearing shall be available for review at the Office of Administrative Hearings. Within three business days after the expiration of the comment period, the Department and interested persons may respond in writing to any new information received during the comment period; however, no additional evidence may be submitted during this three-day period. All written material must be received at the Office of Administrative Hearings no later than 4:30 p.m. on the final day.

The Department requests that any person submitting written views or data to the Administrative Law Judge prior to the hearing or during the comment period after the hearing also submit a copy of the written data to B. James Berg at the address stated above.

**NOTICE:** Any person may request notification of the date on which the Administrative Law Judge's report will be available, after which date the agency may not take any final action on the rules for a period of five working days. If you desire to be so notified, you may so indicate at the hearing. After the hearing, you may request notification by sending a written request to the Administrative Law Judge. Any person may request notification of the date on which the rules were adopted and filed with the Secretary of State. The notice must be mailed on the same day that the rules are filed. If you want to be so notified you may so indicate at the hearing or send a request in writing to the agency at any time prior to the filing of the rules with the Secretary of State.

*Minnesota Statutes*, Chapter 10A (1990) requires each lobbyist to register with the State Ethical Practices Board. Questions regarding this requirement may be directed to the Ethical Practices Board at 625 North Robert Street, St. Paul, Minnesota, 55101-2500, telephone number (612) 296-5148.

**V. Notice of Intent to Cancel the Hearing with Respect to the Rules if Fewer than 25 Persons Request a Hearing with Respect to the Proposed Rules**

**Please note that the hearing, notice of which is given in Part IV above, will be cancelled if fewer than 25 persons request a hearing with respect to the proposed rules in response to the notice given in Part III above.**

To be informed whether a hearing in Part IV above will be held, please contact B. James Berg at the address listed above and provide your name, address, and telephone number. You will be notified on or after May 21, 1992, if the hearing has been cancelled. You may also call Mr. Berg at (612) 297-1727 on or after May 21, 1992, for oral confirmation regarding the scheduled hearing.

Dated: 3 April 1992

John B. Lennes, Jr.  
Commissioner

**Rules as Proposed (all new material)**

**5230.5000 MINIMUM STANDARDS.**

Parts 5230.5000 to 5230.6200 form the code for ammonia refrigeration systems and applies to ammonia piping systems used for closed circuit refrigeration systems. Parts 5230.5000 to 5230.6200 are minimum standards and are not intended to be used as or considered as a system design manual except as otherwise specified. If a system has any component designed for temperatures below minus 20 degrees Fahrenheit (minus 28.9 degrees centigrade), then the entire system, including components, must meet the test requirements of the American Society of Mechanical Engineers, American National Standards Institute, B31.5 refrigerating systems for operating at temperatures below minus 20 degrees Fahrenheit (minus 28.9 degrees centigrade).

**5230.5010 INCORPORATIONS BY REFERENCE.**

Items A to E are documents incorporated by reference in parts 5230.5000 to 5230.6200 to the extent of the cited references. The documents are subject to frequent change and are available through the Minitex interlibrary loan system.

A. 1989 American Society of Mechanical Engineers Boiler and Pressure Vessel Code, section VIII, division 1 and section IX; 1989 American Society of Mechanical Engineers, American National Standards Institute, standard B31.5, refrigeration piping; and 1989 American Society of Mechanical Engineers, American National Standards Institute, standard A13.1 scheme for the identification of piping. American Society of Mechanical Engineers, 345 East 47th Street, New York, New York 10017.

**KEY: PROPOSED RULES SECTION** — Underlining indicates additions to existing rule language. ~~Strike outs~~ indicate deletions from existing rule language. If a proposed rule is totally new, it is designated "all new material." **ADOPTED RULES SECTION** — Underlining indicates additions to proposed rule language. ~~Strike outs~~ indicate deletions from proposed rule language.

## Proposed Rules

B. 1990 American Welding Society, Structural Welding Code-Steel, American National Standards Institute, standard D1.1-90. American Welding Society, 550 Northwest LeJeune Road, Post Office Box 351040, Miami, Florida 33135.

C. 1989 American National Standards Institute, standard Z87.1, Practice for Occupational and Educational Eye and Face Protection, American National Standards Institute, Inc., 1430 Broadway, New York, New York 10018.

D. 1990 Annual Book of American Society for Testing and Materials, Volume 01.01, Steel - Piping, Tubing, Fittings, Publication Number: 01-010190-02, American Society for Testing and Materials, 1916 Race Street, Philadelphia, Pennsylvania 19103-1187.

### 5230.5015 AMMONIA TASK FORCE.

When a technical organization recognized by the ammonia industry, for example, the American Society of Mechanical Engineers, International Institute for Ammonia Refrigeration, or the American Society of Heating, Refrigeration and Air Conditioning Engineers, adopts substantial changes or modifications in nationally recognized standards for ammonia, a task force of industry representatives may be appointed by the commissioner of the Department of Labor and Industry. The purpose of the ammonia task force will be to review the changes in the standards and to recommend to the commissioner the adoption of applicable changes.

### 5230.5020 DEFINITIONS.

Subpart 1. **Scope.** For purposes of parts 5230.5000 to 5230.6200, the following terms are defined in this part.

Subp. 2. **Accessible.** "Accessible" means to be accessible for inspection or service, such as exposed in shafts, tunnels, or concealed by readily removable construction.

Subp. 3. **Administrative authority.** "Administrative authority" means the inspection agency authorized to inspect high pressure piping under *Minnesota Statutes*, sections 326.46 and 326.47, subdivision 2.

Subp. 4. **Air cooled condenser.** "Air cooled condenser" means a condenser, including methods for forcing air circulation over the external surface of the condenser coil, for the heat removal necessary to liquify refrigerant vapor on the inside of the tubes.

Subp. 5. **Air cooled desuperheater.** "Air cooled desuperheater" means that part of the system designed to cool the ammonia refrigerant vapor after it is discharged from the compressor and before it enters the condenser with a means of forcing air circulation over the external surface of the desuperheater coil for the heat removal necessary to cool the refrigerant vapor on the inside of the tubes. It does not include desuperheaters that are integral components of condensers.

Subp. 6. **Anhydrous ammonia.** "Anhydrous ammonia," as used in parts 5230.5000 to 5230.6200, refers to the compound formed by a combination of two gaseous elements, nitrogen and hydrogen. Anhydrous ammonia may be in either gaseous or liquid form. It does not include aqua ammonia (unless as part of a mechanical refrigeration system) which is a solution of ammonia gas in water. When the term ammonia appears, it refers to refrigerant grade anhydrous ammonia, refrigerant 717 (R 717). Anhydrous ammonia also includes mixtures of ammonia and other substances which may act to dilute the ammonia for refrigeration.

Subp. 7. **Approved.** "Approved" means acceptable to the administrative authority having jurisdiction under *Minnesota Statutes*, sections 326.46 and 326.47, subdivision 2, the building inspector under *Minnesota Statutes*, sections 16B.61 and 16B.62, the electrical inspector under *Minnesota Statutes*, section 326.241, or the plumbing inspector under *Minnesota Statutes*, section 326.37.

Subp. 8. **An approved nationally recognized testing laboratory.** "An approved nationally recognized testing laboratory" means a laboratory that provides uniform testing and examination procedures under established standards, has personnel with recognized credentials, is properly organized, equipped, and qualified for testing, and has a follow-up inspection service of the current production of the listed products.

Subp. 9. **Automatic expansion valve.** "Automatic expansion valve" means a controlling device that regulates the flow of volatile liquid refrigerant into an evaporator of a refrigeration system and that is actuated toward opening by a lowering of the evaporator pressure below the setting of the valve spring.

Subp. 10. **Automatic liquid refrigerant drain valve.** "Automatic liquid refrigerant drain valve" has the meaning given a high side float valve in subpart 31.

Subp. 11. **Brine.** "Brine" means any liquid used for the transmission of heat without a change in its state.

Subp. 12. **Check valve.** "Check valve" means a control device that permits fluid to flow through the device in one direction, but prevents return of the fluid in the opposite direction.

Subp. 13. **Companion valve or block valve.** "Companion valve" or "block valve" means pairs of mating stop valves, valving off sections of systems, arranged so that the sections may be joined before opening the valves or separated after closing them.

Subp. 14. **Compressor.** "Compressor" means a specific machine, with or without accessories, for compressing refrigerant vapor. A booster compressor is a compressor, with or without accessories, for compressing ammonia refrigerant vapor and discharging to the suction system of a higher stage compressor.

Subp. 15. **Compressor unit.** "Compressor unit" means a condensing unit less the condenser and liquid receiver.

Subp. 16. **Condenser.** "Condenser" means that part of the system designed to liquify refrigerant vapor by removal of heat.

Subp. 17. **Condenser coil.** "Condenser coil" means that part of a condenser constructed of pipe or tubing other than a shell and tube or shell and coil type.

Subp. 18. **Condensing unit.** "Condensing unit" means a specific refrigerating machine combination consisting of one or more power-driven compressors, condensers, liquid receivers when required, and the regularly furnished accessories.

Subp. 19. **Container.** "Container" means a cylinder for the transportation of ammonia refrigerant.

Subp. 20. **Design pressure.** "Design pressure" means the maximum allowable working pressure for which a specific part of a system is designed.

Subp. 21. **Downstream pressure regulator.** "Downstream pressure regulator" means a controlling device that regulates the flow of refrigerant gas or liquid or oil through the device from a section of the system to a lower pressure section of the system and that is actuated toward open by a pressure falling below regulator set-point downstream of the regulator orifice.

Subp. 22. **Duct.** "Duct" means a tube or conduit used for conveying air. The air passages of self-contained systems are not air ducts.

Subp. 23. **Evaporator.** "Evaporator" means that part of the system designed to vaporize liquid refrigerant to produce refrigeration effect.

Subp. 24. **Evaporative condenser.** "Evaporative condenser" means a condenser that obtains cooling effect by the evaporation of water in an air stream on the external surface of the tubes for the heat removal necessary to liquify refrigerant vapor on the inside of the tubes.

Subp. 25. **Evaporator pressure regulator.** "Evaporator pressure regulator" means a controlling device that regulates the flow of primarily gaseous refrigerant from an evaporator section of the system into a lower pressure section and that is actuated toward open by a pressure above set-point ahead of the valve.

Subp. 26. **Exit.** "Exit" means a confined passageway immediately adjacent to the door through which people leave a building.

Subp. 27. **Field test.** "Field test" means a test performed in the field to prove system tightness.

Subp. 28. **Forced feed oil lubrication.** "Forced feed oil lubrication" means that oil is positively provided for lubrication by internal or external mechanical oil pump. It does not include splash-type or drip-type compressor lubrication systems.

Subp. 29. **Flow regulator.** "Flow regulator" means a controlling device that regulates the flow of liquid refrigerant through the device from a section of the system to a lower pressure section of the system and that is actuated by flow rate changes to maintain a predetermined flow rate.

Subp. 30. **High side.** "High side" means the parts of an ammonia refrigerating system subjected to condenser pressure.

Subp. 31. **High side float valve.** "High side float valve" means a controlling device that regulates the flow of volatile liquid refrigerant from a higher pressure section of the system into a lower pressure section and that is actuated toward open by a rising liquid level upstream of the valve.

Subp. 32. **Hot gas bypass regulator.** "Hot gas bypass regulator" means a controlling device that regulates the flow of refrigerant hot gas through the device from a higher pressure section of the system to a lower pressure section of the system and that is actuated toward open by a pressure falling below regulator set-point downstream of the regulator orifice.

Subp. 33. **Inaccessible.** "Inaccessible" means those sections of piping systems installed in walls, floors, ceiling, or other areas where access cannot be made without the removal of permanent construction.

Subp. 34. **Internal gross volume.** "Internal gross volume" means the volume determined from internal dimensions of the container as if the internal parts of the container were not there.

Subp. 35. **Listed.** "Listed" means equipment that has been tested and is identified as acceptable by an approved nationally recognized testing laboratory.

Subp. 36. **Liquid receiver.** "Liquid receiver" means a pressure vessel permanently connected to a refrigerating system by inlet and outlet pipes for storage of liquid refrigerant.

Subp. 37. **Low side.** "Low side" means the parts of a refrigerating system subjected to evaporator pressure.

**KEY: PROPOSED RULES SECTION** — Underlining indicates additions to existing rule language. ~~Strike outs~~ indicate deletions from existing rule language. If a proposed rule is totally new, it is designated "all new material." **ADOPTED RULES SECTION** — Underlining indicates additions to proposed rule language. ~~Strike outs~~ indicate deletions from proposed rule language.

## Proposed Rules

---

---

Subp. 38. **Liquid line.** "Liquid line" means the parts of the system subjected to condenser pressure including those parts where the piping is partly or wholly filled with liquid refrigerant.

Subp. 39. **Low side float valve.** "Low side float valve" means a controlling device that regulates the flow of volatile liquid refrigerant into an evaporator pressure section of the system from a higher pressure section and that is actuated toward closed by a rising liquid level downstream of the valve.

Subp. 40. **Machinery.** "Machinery" means the refrigerating equipment forming a part of the refrigerating system, including but not limited to any or all of the following:

- A. compressor;
- B. condenser;
- C. liquid receiver;
- D. connecting piping; or
- E. evaporator.

Subp. 41. **Machinery room.** "Machinery room" means a room in which a refrigerating system is permanently installed and operated with a one-hour fire separation from the rest of the building, but not including evaporators located in a cold storage room, refrigerator box, air-cooled space, or other enclosed space. A machinery room is defined as being in a building, part of a building, attached to a building, adjacent to a building, or detached and separate from a building. An independent mechanical ventilation system that complies with part 5230.5710 must be provided.

Closets solely contained within, and opening only into, a room are not considered to be machinery rooms, but must be considered a part of the machinery room in which they are contained or open into. Spaces in which a self-contained system is located are not classified as a machinery room.

Machinery rooms must comply with part 5239.5705. Machinery rooms must have a floor drain and backflow preventer that complies with the Minnesota State Plumbing Code, chapter 1355. For the purposes of parts 5230.5000 to 5230.6200, machinery room and equipment room have the same meaning.

Subp. 42. **Machinery room, class T.** "Machinery room, class T" means a machinery room as defined by subpart 41 that complies with the specific requirements of items A to H:

- A. any doors opening into the building must be approved self-closing, tight-fitting fire doors;
- B. the walls, floor, and ceiling must be tight and of not less than one-hour fire-resistive construction and all penetrations must be fire stopped;
- C. it must have an exit door that opens directly to the outer air or through a vestibule-type exit equipped with self-closing, tight-fitting doors;
- D. exterior openings, if present, must not be under any fire escape or any open stairway;
- E. pipes piercing the interior walls, ceiling, or floor of a room must be tightly sealed and fire stopped to the walls, ceiling, or floor through which they pass;
- F. emergency remote controls to stop the action of the refrigerant compressor must be provided and be located immediately outside the machinery room;
- G. emergency remote controls for the mechanical means of ventilation must be provided and be located outside the machinery room; and
- H. no permanently installed flame-producing device or hot surface above 800 degrees Fahrenheit (426.5 degrees centigrade) shall be permitted in the class T machinery room. The electrical equipment in the class T room must conform to the requirements of hazardous locations class I, division 2, of the Minnesota State Electrical Code.

Subp. 43. **Manufacturer.** "Manufacturer" means the company or organization that affixes its name or nationally registered trademark or trade name to the refrigeration equipment concerned.

Subp. 44. **Mechanical joint.** "Mechanical joint" is a gas-tight joint, obtained by the joining of metal parts through a positive holding mechanical construction that is designed and manufactured as suitable for ammonia service.

Subp. 45. **Mechanical refrigeration system.** "Mechanical refrigeration system" means a combination of interconnected refrigerant containing parts constituting one closed refrigerant circuit in which a refrigerant is circulated to extract heat and in which a compressor is used for compressing the ammonia refrigerant vapor.

Subp. 46. **Motorized valve.** "Motorized valve" means a device that regulates the flow of fluid through the device by a motor that moves a plug with respect to an orifice.

Subp. 47. **Nameplate.** "Nameplate" means a metallic plate, suitably and legibly etched or stamped. The size of type must be no smaller than ten point and the plate must be permanently attached in a readily accessible location. The nameplate must contain the information required in parts 5230.5615 to 5230.5640.

Subp. 48. **Nonpositive displacement compressor.** "Nonpositive displacement compressor" means a compressor in which an increase in vapor pressure is attained without changing the internal volume of the compression chamber.

Subp. 49. **Oil drain float valve.** "Oil drain float valve" has the meaning given high side float valve in subpart 31. This reference does not cover control of oil in the system.

Subp. 50. **Pilot operated valve.** "Pilot operated valve" means the valve that regulates flow in response to a signal from a pilot.

Subp. 51. **Piping.** "Piping" means the pipe or tube mains for interconnecting the various parts of a refrigerating system. Piping means the piping system, including:

- A. pipe;
- B. flanges;
- C. bolting;
- D. gaskets;
- E. valves;
- F. fittings;

G. the pressure containing parts of other components such as expansion joints, strainers, and devices that serve such purposes as mixing, separating, snubbing, distributing, metering, or controlling flow;

- H. piping supporting fixtures; and
- I. structural attachments.

Subp. 52. **Positive displacement compressor.** "Positive displacement compressor" means a compressor in which an increase in pressure is attained by changing the internal volume of the compression chamber.

Subp. 53. **Pressure imposing element.** "Pressure imposing element" means any device or portion of the equipment used to increase the refrigerant vapor pressure.

Subp. 54. **Pressure relief device.** "Pressure relief device" means a reseating type pressure actuated valve designed to automatically relieve excessive pressure.

Subp. 55. **Pressure relief valve or safety valve.** "Pressure relief valve" is also called a "safety valve" and means a reseating type pressure actuated valve held closed by a spring or other means and designed to automatically relieve pressure in excess of its setting.

Subp. 56. **Pressure vessel.** "Pressure vessel" means any refrigerant containing receptacle of a refrigerating system other than evaporators, where each separate section of the evaporator does not exceed one-half foot<sup>3</sup> (0.014 meter<sup>3</sup>) of refrigerant containing volume, evaporator coils, compressors, condenser coils, controls, headers, pumps, and piping.

Subp. 57. **Readily accessible.** "Readily accessible" means capable of being reached safely and quickly for operation, repair, or inspection without requiring those to whom ready access is requisite to climb over or remove obstacles, or to resort to the use of portable access equipment and tools.

Subp. 58. **Refrigerant.** "Refrigerant" means a substance used to produce refrigeration by its expansion or vaporization.

Subp. 59. **Refrigerant pressure activated condenser water regulator.** "Refrigerant pressure activated condenser water regulator" means a device that regulates the flow of cooling water through the device to or from a water-cooled condenser and that is actuated toward open by refrigerant high side pressure rising above the regulator set point.

Subp. 60. **Refrigerant pump.** "Refrigerant pump" means a mechanical device for moving liquid ammonia refrigerant within a closed circuit mechanical refrigeration system.

Subp. 61. **Rupture member.** "Rupture member" means a device designed to rupture at a predetermined pressure. Rupture members are prohibited.

**KEY: PROPOSED RULES SECTION** — Underlining indicates additions to existing rule language. ~~Strike outs~~ indicate deletions from existing rule language. If a proposed rule is totally new, it is designated "all new material." **ADOPTED RULES SECTION** — Underlining indicates additions to proposed rule language. ~~Strike outs~~ indicate deletions from proposed rule language.

## Proposed Rules

Subp. 62. **Saturation pressure.** "Saturation pressure" of a refrigerant is the pressure at which there is stable coexistence of the vapor and liquid or the vapor and solid phase.

Subp. 63. **Self-contained system.** "Self-contained system" means a complete factory-made and factory-tested system in a suitable frame or enclosure that is fabricated and shipped in one or more sections and in which no refrigerant-containing parts are connected in the field other than by companion or block valves.

Subp. 64. **Shell and tube condenser.** "Shell and tube condenser" means a type of condenser where tubes in a bundle with each end secured in a tube sheet are enclosed in a shell with refrigerant in the shell. A shell and tube condenser with refrigerant in the shell is a pressure vessel.

Subp. 65. **Shell and tube evaporator.** "Shell and tube evaporator" means a type of evaporator where tubes or coils are enclosed in a shell. Flooded type has the evaporating ammonia in the shell. Direct expansion type has the evaporating ammonia in the tubes or coils.

Subp. 66. **Solenoid valve.** "Solenoid valve" means a valve that is opened or closed by the magnetic action of an electrically energized coil. The opposite action is accomplished by gravity, pressure, or spring action.

Subp. 67. **Stop valve.** "Stop valve" means a device to shut off the flow.

Subp. 68. **Test pressure.** "Test pressure" means the minimum pressure, pounds per square inch gage, to which a specific part is subjected under test condition.

Subp. 69. **Thermostatic expansion valve.** "Thermostatic expansion valve" means a controlling device that regulates the flow of volatile refrigerant into an evaporator of a refrigeration system and which is actuated by changes in evaporator pressure and superheat of the refrigerant gas leaving the evaporator. Its basic response is to superheat.

Subp. 70. **Three-way type stop valve.** "Three-way type stop valve" means a manually operative valve with one inlet that alternately can stop flow to either of two outlets.

Subp. 71. **Ultimate strength.** "Ultimate strength" means the highest stress level that the component can tolerate without rupture.

Subp. 72. **Unprotected tubing.** "Unprotected tubing" means tubing that is not protected by enclosure or suitable location so that it is exposed to crushing, abrasion, puncture, or similar mechanical damage under installed conditions.

Subp. 73. **Upstream pressure regulator.** "Upstream pressure regulator" means a controlling device that regulates the flow of refrigerant gas or liquid or oil through the device from a section of the system to a lower pressure section of the system and that is actuated toward open by a pressure rising above regulator set-point upstream of the regulator orifice.

Subp. 74. **Welded joint.** "Welded joint" means a gas-tight joint, obtained by the joining of metal parts in molten state.

### 5230.5025 AMMONIA GOVERNED AND DEFINED.

Ammonia is defined in part 5230.5020, subpart 6. Only refrigerant grade ammonia may be used in ammonia refrigerant systems. The maximum allowable concentration of ammonia in refrigeration systems is 50 parts per million ambient. The ammonia must be clear, colorless liquid or gas free from visible impurities. Refrigeration grade anhydrous ammonia must contain at least 99.95 percent pure ammonia for charging both new and old refrigeration systems.

The flammable limits at atmospheric pressure are 16 percent and 25 percent by volume of ammonia in air. An ammonia-air mixture in an iron flask does ignite at 1204 degrees Fahrenheit (651 degrees centigrade). The addition of refrigerant oil to ammonia, when released from the system, can act to increase the hazard of combustion.

At 50 parts per million, its odor is detectable by most people. Since ammonia gas is lighter than air, adequate ventilation is the best means of preventing an accumulation of ammonia.

The physical properties and specifications of refrigerant grade ammonia are:

#### PHYSICAL PROPERTIES OF AMMONIA

| ENGLISH  | COMMON METRIC     | SI                 |
|--|-------------------|--------------------|
| A. Molecular symbol<br>NH <sub>3</sub>                 | NH <sub>3</sub>   | NH <sub>3</sub>    |
| B. Molecular weight<br>17.032                          | 17.032            | 17.032             |
| C. Boiling point at one atmosphere*<br>-28 degrees F   | (-33.3 degrees C) | (239.85 degrees K) |
| D. Freezing point at one atmosphere*<br>-108 degrees F | (-77.6 degrees C) | (195.55 degrees K) |



| ENGLISH  | COMMON METRIC   | SI                 |
|--|-----------------|--------------------|
| E. Critical temperature<br>271.4 degrees F   | (133 degrees C) | (406.15 degrees K) |
| F. Critical pressure<br>1657 psig  | (116.2 kg/cm)   | (11.42 M Pa)       |
| G. Latent heat at -28 degrees Fahrenheit (-33.3 degrees centigrade) and one atmosphere*<br>589.3 Btu/lb  | (332.4 cal/gm)  | (13.92 MJ/kg)      |
| H. Relative density of vapor compared to dry air at 32 degrees Fahrenheit (0 degrees centigrade) and one atmosphere*<br>0.5963                                   | 0.5963          | 0.5963             |
| I. Vapor density at -28 degrees Fahrenheit (-33.3 degrees centigrade) and one atmosphere*<br>0.05555 lb/ft <sup>3</sup>  | (0.889 kg/m)    | (0.889 kg/m)       |
| J. Specific gravity of liquid at -28 degrees Fahrenheit (-33.3 degrees centigrade) compared to water at 39.2 degrees Fahrenheit (4 degrees centigrade)<br>0.6821 | 0.6821          | 0.6821             |
| K. Liquid density at -28 degrees Fahrenheit (-33.3 degrees centigrade) and one atmosphere*<br>42.56 lb/ft  | (6.819 kg/m)    | (6.819 kg/m)       |
| L. Specific volume of vapor at 32 degrees Fahrenheit (0 degrees centigrade) and one atmosphere*<br>20.78 ft/lb   | (1.29 m/kg)     | (1.29 m/kg)        |
| M. Flammable limits by volume in air at atmospheric pressure<br>16% to 25%   | 16% to 25%      | 16% to 25%         |
| N. Ignition temperatures<br>1204 degrees F   | 651 degrees C   | (924.15 K)         |
| O. Specific heat, gas 59 degrees Fahrenheit (15 degrees centigrade) one atmosphere*  |                 |                    |
| (1) at constant pressure, Cp<br>0.519 btu/lb deg F   | 0.519 cal/gm C  | (2189.0 J/kgK)     |
| (2) at constant volume, Cv<br>0.3995 Btu/lb deg F  | 0.3995 cal/gm C | (1672 J/kgK)       |
| * One atmosphere equals:<br>14.71 psia   | (1.033 Kg/cm)   | (101.4 KPa)        |

Refrigerant grade ammonia must meet the following purity requirements:

- (1) ammonia content determined by evaporative residue test, 99.95 percent minimum;
- (2) nonbasic gas in vapor phase, 25 parts per million maximum;
- (3) nonbasic gas in liquid phase, ten parts per million maximum;
- (4) water, 33 parts per million maximum;
- (5) oil as soluble in petroleum ether, two parts per million maximum;
- (6) salt calculated as NaCl, none; and
- (7) pyridine, hydrogen sulfide, naphthalene, none.

**5230.5250 LOCATIONS GOVERNED AND DEFINED.**

Subpart 1. **Locations governed.** Locations governed by parts 5230.5000 to 5230.6200 in which ammonia piping systems may be placed are grouped by occupancy, as defined in subparts 2 to 8.

Subp. 2. **Institutional occupancy.** "Institutional occupancy" applies to that portion of a premise in which persons are confined to receive medical, charitable, education, or other care or treatment, or in which persons are held or detained by reason of public or civic duty, including hospitals, nursing homes, asylums, sanitariums, police stations, jails, courthouses with cells, and similar occupancies.

**KEY: PROPOSED RULES SECTION** — Underlining indicates additions to existing rule language. ~~Strike outs~~ indicate deletions from existing rule language. If a proposed rule is totally new, it is designated "all new material." **ADOPTED RULES SECTION** — Underlining indicates additions to proposed rule language. ~~Strike outs~~ indicate deletions from proposed rule language.

## Proposed Rules

---

---

Subp. 3. **Public assembly occupancy.** "Public assembly occupancy" applies to that portion of a premise in which persons congregate for civic, political, educational, religious, social, or recreational purposes, including armories, assembly rooms, auditoriums, ballrooms, bath houses, bus terminals, broadcasting studios, churches, colleges, courthouses without cells, dance halls, department stores, exhibition halls, fraternity halls, libraries, lodge rooms, mortuary chapels, museums, passenger depots, schools, skating rinks, subway stations, theaters, enclosed portions of arenas, racetracks, and stadiums and similar occupancies.

Subp. 4. **Residential occupancy.** "Residential occupancy" applies to that portion of a premise in which sleeping accommodations are provided, including clubhouses, convents, dormitories, hotels, lodging houses, multiple story apartments, residences, studios, tenements, and similar occupancies.

Subp. 5. **Commercial occupancy.** "Commercial occupancy" applies to that portion of a premise used for the transaction of business, for the rendering of professional services, for the supplying of food, drink, or other bodily needs and comforts, for manufacturing purposes, or for the performance of work or labor not included under subpart 6, industrial occupancy. Examples of commercial occupancy for work or labor not covered under industrial occupancy are bake shops, fur storage facilities, laboratories, loft buildings, markets, office buildings, professional buildings, restaurants, and stores other than department stores.

Subp. 6. **Industrial occupancy.** "Industrial occupancy" applies to an entire building or premises or to that portion of a building used for manufacturing, processing, or storage of materials or products. Representative examples include chemical, food, candy and ice cream factories, ice-making plants, meat packing plants, refineries, perishable food warehouses and similar occupancies. In an industrial occupancy, when the number of persons in a refrigerated space, served by a direct system, on any floor above the first floor ground level or dock level, exceeds one person per 100 square feet (9.29 square meters) of floor area, the requirements of commercial occupancy apply unless that refrigerated space is provided with the required number of doors opening directly into building exits approved by the building inspector.

The refrigerated space must be cut off from the rest of the building by tight construction of at least one-hour fire rating with tight-fitting doors as required by the Minnesota State Building Code.

This subpart does not prohibit openings for the passage of products from one refrigerated space to another refrigerated space.

For the purpose of this subpart, "approved building exits" means approval according to the standards promulgated by the National Fire Protection Association and as approved by the building inspector having jurisdiction.

Subp. 7. **Mixed occupancy.** "Mixed occupancy" applies to a building occupied or used for different purposes in different parts. When the occupancies are cut off from the rest of the building by tight partitions, floors, ceilings, fire stopped, and protected by self-closing doors, the requirements for each type of occupancy apply for its portion of the building premises. For example, the cold storage spaces in retail frozen food lockers, hotels, and department stores might be classified under industrial occupancy, while other portions of the building would be classified under other occupancies. When the occupancies are not separated, the occupancy carrying the more stringent requirements governs.

Subp. 8. **Adjacent locations.** Placement of ammonia refrigeration equipment, other than piping, installed in locations adjacent to areas described in this part and located outside of, but less than 20 feet (6.10 meters) from any building opening is governed by the occupancy classification of the building. Equipment installed in a nonadjacent location, such as equipment in a separate building located 20 feet (6.10 meters) or more from an opening in any other building, is considered a separate building and is governed by this part.

### 5230.5300 REFRIGERATING SYSTEM CLASSIFICATION BY TYPE.

Subpart 1. **Refrigerating systems.** Refrigerating systems are classified by the method employed for extracting heat in subparts 2 to 4 and as the drawing in subpart 5.

Subp. 2. **Direct system.** A direct system is one in which the evaporator is in direct contact with the material or space refrigerated or is located in air-circulating passages communicating with these spaces.

Subp. 3. **Double direct system.** A double direct system means one in which an evaporative refrigerant is used in a secondary circuit to condense or cool a refrigerant in a primary circuit.

Subp. 4. **Indirect system.** An indirect system means one in which a brine, cooled by the refrigerant, is circulated to the material or space refrigerated or is used to cool air so circulated. Indirect systems that are distinguished by the type of method of application are described in items A to D.

A. "Indirect open-spray system" means one in which a brine, cooled by an evaporator located in an enclosure external to a cooling chamber, is circulated to a cooling chamber, and is sprayed in the cooling chamber.

B. "Indirect closed surface system" means one in which a brine, cooled by an evaporator located in an enclosure external to a cooling chamber, is circulated to and through a cooling chamber in pipes or other closed circuits.

C. "Indirect vented closed surface system" means one in which a brine, cooled by an evaporator located in a vented enclosure external to a cooling chamber, is circulated to and through a cooling chamber in pipes or other closed circuits.

D. "Double indirect vented open spray system" means one in which a brine, cooled by an evaporator located in a vented enclosure, is circulated through a closed circuit to a second enclosure where it cools another supply of a brine and this liquid in turn is circulated to a cooling chamber and is sprayed in the cooling chamber.

Subp. 5. **Direct and indirect systems diagram.** The following diagram illustrates direct and indirect refrigerating systems as defined in subparts 1 to 4.

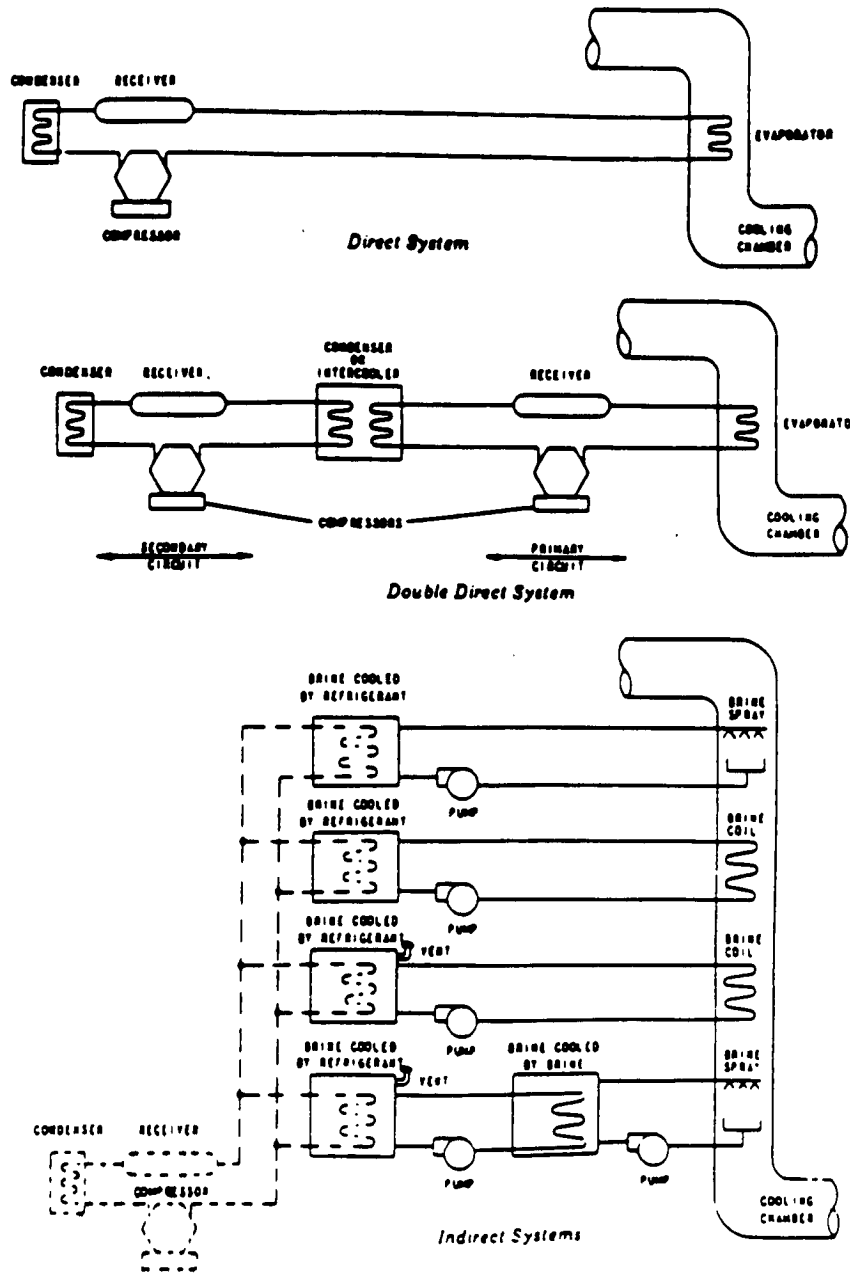

**KEY: PROPOSED RULES SECTION** — Underlining indicates additions to existing rule language. ~~Strike outs~~ indicate deletions from existing rule language. If a proposed rule is totally new, it is designated "all new material." **ADOPTED RULES SECTION** — Underlining indicates additions to proposed rule language. ~~Strike outs~~ indicate deletions from proposed rule language.

## Proposed Rules

### 5230.5350 RESTRICTIONS ON PLACEMENT OF AMMONIA PIPING, LIMITATIONS ON SYSTEM SIZING, AND PRESSURE RELIEF VENTING REQUIREMENTS.

Subpart 1. **Scope.** Placement of ammonia piping is restricted according to subparts 2 to 16.

Subp. 2. **Public stairway, stair landing, entrance, or exit.** No portion of an ammonia piping system is permitted to be installed in or on a public stairway, stair landing, entrance, or exit.

Subp. 3. **Public hallway or lobby.** No portion of an ammonia piping system must interfere with free passage through public hallways or lobbies. No portion of a refrigerating system containing ammonia piping is permitted in public hallways or lobbies of institutional or public assembly occupancies. Ammonia piping systems installed in a public hallway or lobby shall be limited to sealed absorption systems containing not more than three pounds (1.36 kilogram) of an ammonia refrigerant when in residential and commercial occupancies.

Subp. 4. **Enclosed space; refrigerant quantity limits.** When the refrigerant-containing parts of an ammonia piping system are located in one or more enclosed spaces, the cubic area of the smallest enclosed occupied space, other than the machinery room, must be used to determine the permissible quantity of refrigerant in the system. Where a refrigerating system has evaporator coils serving individual stories of a building, the story having the smallest volume must be used to determine the maximum quantity of refrigerant in the entire system.

Subp. 5. **Air duct.** When the evaporator is located in an air duct system, the cubic area of the smallest occupied enclosed space served by the air duct system must be used to determine the permissible quantity of refrigerant in the system.

Subp. 6. **Suspended ceiling.** Where the return air space above a suspended ceiling is one continuous space and not an enclosed air duct in which the return air is confined, this space may be included in calculating the cubic area of the occupied space.

Subp. 7. **External venting.** In institutional and public assembly occupancies, direct expansion coils or evaporators used for air conditioning and located downstream from and in proximity to a heating coil, or located upstream within 18 inches (0.46 meter) of a heating coil, must be fitted with a pressure relief device discharging to the outside of the building; except that a relief device shall not be required on units or self-contained systems if the internal volume of the low side of the system that may be shut off by valves, divided by the total weight of refrigerant in the system, less the weight of refrigerant vapor contained in the other parts of the system at 110 degrees Fahrenheit (43.5 degrees centigrade) exceeds the specific volume of the refrigerant at critical conditions of temperature and pressure.

The exemption is stated in formula form as follows:

$$\frac{V1}{(W1-W2)}$$

\*V1/W1-W2 shall be more than Vgc where V1 equals low side volume, cubic feet (cubic meter)

\*Vgc equals specific volume at critical conditions of temperature and pressure, cubic feet per pound (cubic meter per kilogram)

\*W1 equals total weight of refrigerant in system, pound (kilogram)

\*V2 equals total volume of system less V1 cubic foot (cubic meter)

\*Vgt equals specific volume of refrigerant vapor at 110 degrees Fahrenheit (43.5 degrees centigrade), foot<sup>3</sup>/pound cubic (meter<sup>3</sup>/kilogram)

\*W2 equals V2/Vgt equals weight of refrigerant vapor in V2 at 110 degrees Fahrenheit (43.5 degrees centigrade)

#### Subp. 8. **Maximum quantities.**

A. Direct systems containing ammonia refrigerants must not be used for air conditioning for human comfort. For other applications, the maximum permissible quantity of ammonia refrigerants in a direct system must be as specified in subpart 9.

B. The maximum permissible quantity of an ammonia refrigerant in any indirect system must be as specified in subpart 10. As provided in this part, these systems must be of the following type:

(1) institutional and public assembly occupancies shall have indirect vented closed-surface, or double indirect vented open spray systems; and

(2) residential and commercial occupancies shall have indirect closed-surface, indirect vented closed-surface, or double indirect vented open-spray, or secondary circuit of double direct type systems.

Subp. 9. **Maximum permissible quantity of ammonia refrigerants for direct systems.** The maximum permissible quantity of ammonia refrigerants for direct systems for each type of refrigerating system with maximum pounds (kilograms) for various occupancies are contained in the following table:

|   | Type of Refrigerating System |                 |             |            |
|---|------------------------------|-----------------|-------------|------------|
|   | Institutional                | Public Assembly | Residential | Commercial |
| Sealed Absorption Systems                   |                              |                 |             |            |
| A. In public hallways or lobbies            | 0 (0)                        | 0 (0)           | 3 (1.36)    | 3 (1.36)   |
| B. In other than public hallways or lobbies | 0 (0)                        | 6 (2.7)         | 6 (2.7)     | 20 (9.07)  |
| Self-Contained or Unit Systems              |                              |                 |             |            |
| A. In public hallways or lobbies            | 0 (0)                        | 0 (0)           | 0 (0)       | 0 (0)      |
| B. In other than public hallways or lobbies | 0 (0)                        | 0 (0)           | 6 (2.7)     | 20 (9.07)  |

Subp. 10. **Maximum permissible quantities of ammonia refrigerants for indirect systems.** The maximum permissible quantities of ammonia refrigerants for indirect systems are contained in the following table:

| Occupancy       | Class T Machinery room maximums |
|-----------------|---------------------------------|
| Institutional   | 500 pounds (226.8 kilograms)    |
| Public assembly | 1,000 pounds (453.6 kilograms)  |
| Residential     | 500 pounds (226.8 kilograms)    |
| Commercial      | 500 pounds (226.8 kilograms)    |

A class T machine room for indirect systems using ammonia refrigerants for institution, public assembly, residential, and commercial occupancies is required except as otherwise noted in items A, B, and D.

A. Indirect systems using ammonia refrigerants and conforming with this subpart, subparts 8, item A, and 9 for direct systems are permitted.

B. Indirect systems using ammonia refrigerants, not in excess of the quantities shown in subpart 10, other than systems conforming with items A and D, must have all refrigerant-containing parts, except piping, installed in class T machinery room as defined in part 5230.5500, subpart 42. Air-cooled or evaporative condensers may be installed outside the building. Piping must be installed according to part 5230.5945. The class T machinery room must be used for refrigerant equipment only.

C. Indirect systems using ammonia refrigerant may exceed the quantity limitations of subpart 10, and the limits in subpart 10 may be tripled only if there is a class T machinery room, and:

(1) There must be a separate building housing only the machinery room or a cut-off machinery room that cannot be entered except from outside, with no openings to the inside; including doors, windows, grills, ducts, chases, or other openings into the adjacent building. Where steel pipe penetrates a wall, the individual steel pipes must penetrate the wall through individual steel sleeves, sealed vapor tight, and fire stopped to a rating equal to the assembly being penetrated.

(2) The machinery room must have doors, walls, floors, and ceilings made up of components and assemblies with at least a two-hour fire rating and all penetrations must be fire stopped to this rating. Penetrations must be smoke stopped.

(3) The machinery room must have a water sprinkler system actuated by fire, smoke, ammonia leak, or manual control. The manual control for the water sprinkler must have at least one switch readily accessible inside the machinery room and at least one switch readily accessible outside of the machinery room.

(4) The machinery room must be vapor and liquid tight on all sides contiguous to the main building.

(5) Electrical components in the machinery room must be Minnesota State Electrical Code, class I, division 2, location type electrical components.

(6) The machinery room must be provided with a ventilation system that complies with the requirements of part 5230.5710 and that provides ventilation that is at least twice the free area and volume that is required by part 5230.5710, subpart 9, for the quantity of refrigerant in the systems.

**KEY: PROPOSED RULES SECTION** — Underlining indicates additions to existing rule language. ~~Strike outs~~ indicate deletions from existing rule language. If a proposed rule is totally new, it is designated "all new material." **ADOPTED RULES SECTION** — Underlining indicates additions to proposed rule language. ~~Strike outs~~ indicate deletions from proposed rule language.

## Proposed Rules

(7) The machinery room must have at least one floor drain and backflow preventer that complies with the Minnesota State Plumbing Code, chapter 1355.

(8) Only ammonia refrigeration equipment must be located in this machinery room and the machinery room must comply with the requirements for machinery rooms of applicable portions of parts 5230.5000 and 5230.6200.

D. A sealed ammonia-water absorption unit system containing not more than 20 pounds (9.07 kilograms) of ammonia and installed outdoors adjacent to a commercial or residential occupancy is not required to conform with this subpart.

Subp. 11. **Flame-producing devices, hot surfaces, and electrical equipment in class T machinery rooms.** Where a class T machinery room is provided to comply with subpart 10, item B, to house a refrigerating system containing any ammonia refrigerant, the machinery room must comply with part 5230.5705.

Subp. 12. **Ammonia piping height.** Ammonia piping crossing an open space that affords passageway in a building must be at least 7-1/2 feet (2.29 meters) above the floor unless against the ceiling of the space.

Subp. 13. **Prohibited locations.** Free passageway must not be obstructed by ammonia piping. Ammonia piping must not be placed in any elevator, dumbwaiter, or other shaft containing a moving object, or in any shaft that has openings to living quarters or to main exit hallways. Ammonia piping must not be placed in public hallways, lobbies, or stairways except as noted in subpart 3.

Subp. 14. **Occupancy exception.** The provisions of this part apply to all occupancies; except that industrial occupancies as defined in part 5230.5250 are not subject to the limitations on permissible quantities. In areas of public assembly, the more restrictive requirements of this part apply.

Subp. 15. **Ammonia piping installed vertically.** Ammonia piping must not be installed vertically through floors from one story to another except as follows:

A. Ammonia piping may be installed from the basement to the first floor; from the top floor to a machinery penthouse or to the roof; or between adjacent floors served by the refrigerating system and the opening for the piping must be fire stopped;

B. To interconnect separate pieces of equipment not located as described in item A, ammonia piping may be carried in rigid and tight continuous fire resisting pipe duct or shaft having no openings into floors not served by the refrigerating system and a one-hour fire rating. The pipe duct or shaft must be vented to the outside and fire stopped when penetrated; or

C. Ammonia piping may be carried on the outside of the outer wall of the building.

Subp. 16. **Ammonia piping installed horizontally.** Ammonia piping may be installed horizontally in closed floors or in open joist spaces. Piping installed in concrete floors must be encased in pipe duct.

### 5230.5400 REQUIREMENTS FOR INDUSTRIAL OCCUPANCIES.

Subpart 1. **Quantity of refrigerant.** There is no maximum quantity of ammonia refrigerant in an industrial occupancy. Other requirements of part 5230.5350 apply.

Subp. 2. **Machinery room.** When ammonia is used in a refrigerating system, refrigerant containing parts, except piping and evaporators, and refrigerant containing components installed outside the building, shall be installed in a machinery room as defined in part 5230.5020, subpart 41 or 42, and the machinery room must comply with the applicable portions of parts 5230.5000 to 5230.6200.

Machinery room ventilation must be provided in compliance with the requirements of part 5230.5710.

Subp. 3. **Refrigerated storage areas and work areas.**

A. When ammonia is used, the refrigerant storage area must be considered a hazardous class 1 location according to the Minnesota State Electrical Code.

B. When any ammonia refrigerant is used, reasonable care must be taken to adequately safeguard piping, controls, and other refrigeration equipment in working areas to minimize the possibility of accidental damage or rupture from external sources.

C. Areas through which piping for an ammonia refrigerant is run shall be considered a refrigerated work area.

### 5230.5605 AIR COOLED CONDENSERS.

Subpart 1. **Generally.** This part refers to air cooled condensers that are applied to closed circuit ammonia refrigeration systems.

Subp. 2. **Design criteria.** The design criteria for air cooled condensers is as follows:

A. A minimum design pressure of 300 pounds per square inch gage (21.09 kilograms cm<sup>2</sup>) (2068.0 kPa gage).

B. Air cooled condensers must be designed to withstand air velocities of 100 miles per hour (44.7 m/s).

C. Fans, drives, and motors must be protected with screens or guards according to Occupational Safety and Health Division, Department of Labor and Industry, general requirements for all machines, and mechanical power transmission apparatus, chapter 5205.

D. Propeller, axial, or centrifugal fan speeds must not exceed the safe design speed recommended by the manufacturer for the temperature and nature of application.

E. Manufacturers producing ammonia air cooled condensers must provide the following minimum data on the name plate:

- (1) manufacturer's name;
- (2) year of manufacture;
- (3) design pressure;
- (4) electrical full load amps;
- (5) volts, hertz, and phase;
- (6) refrigerant ammonia;
- (7) identification number; and
- (8) model designation number.

#### **5230.5610 AIR COOLED DESUPERHEATERS.**

The requirements of part 5230.5605 apply to air cooled desuperheaters.

#### **5230.5615 COMPRESSORS.**

Subpart 1. **Generally.** This part applies to compressors that are applied to closed circuit ammonia mechanical refrigeration systems.

Other products covered by this part are rotary vane booster compressors, reciprocating booster and high stage compressors, rotary screw booster and high stage compressors, centrifugal booster and high stage compressors, or other devices that perform this function.

Subp. 2. **Design criteria, compressors.**

A. Minimum design pressures for high stage compressors are:

(1) Water or evaporative cooled condensing, 250 pounds per square inch gage (17.57 kilograms/cm<sup>2</sup> gage) (1724.0 kPa gage); and

(2) Air cooled condensing, 300 pounds per square inch gage (21.09 kilogram/cm<sup>2</sup> gage) (2068.0 gage).

B. Minimum design pressures for booster compressors must be 150 pounds per square inch gage (10.54 kilograms/cm<sup>2</sup> gage) (1034.0 kPa gage).

C. Positive displacement compressors must be equipped by the manufacturer with a pressure relief device of adequate size and pressure setting to prevent rupture of the compressor. The device must be located between the compressor and stop valve on the discharge and may be of the internal or external type relief device. The pressure relief device must discharge into the low pressure side of the system, or to the atmosphere at a location at least 15 feet (4.57 meter) above the adjoining ground level and at least 20 feet (6.1 meter) from any window, ventilator opening, or entrance of any building.

D. A compressor must be provided with a low pressure interlock control and a pressure-limiting, high pressure, interlock device. Compressors using forced feed oil lubrication must be provided with a lubrication failure interlock control. The pressure-limiting device, except for booster compressors, must be of the manual reset type. The setting of the pressure-limiting device must not exceed the lower of the compressor manufacturer's recommendations or 90 percent of the high side pressure relief device setting. The setting of the low pressure control must be according to the compressor manufacturer's recommendations.

E. Compressors must be provided with controls that provide for the compressor starting only when the compressor is unloaded. Compressors must be installed with adequate electrical service and controls to start and run safely and operate in conformity with the manufacturers recommendations.

F. Compressors with motors in excess of 250 horsepower must be equipped with antirecycle timers to prevent short cycling.

G. Compressor coupling guards and belt, pulley, and flywheel guards must be provided in compliance with safety standards set by Occupational Safety and Health Division, Department of Labor and Industry, general requirement for all machines, chapter 5205.

H. If rotation is to be in only one direction, a rotation arrow must be cast-in or permanently attached to the compressor frame.

**KEY: PROPOSED RULES SECTION** — Underlining indicates additions to existing rule language. ~~Strike outs~~ indicate deletions from existing rule language. If a proposed rule is totally new, it is designated "all new material." **ADOPTED RULES SECTION** — Underlining indicates additions to proposed rule language. ~~Strike outs~~ indicate deletions from proposed rule language.

## Proposed Rules

---

- I. For ultimate strength see part 5230.5690.
- J. Manufacturers producing compressors shall provide the following minimum data on the nameplate:
  - (1) maximum design pressure;
  - (2) maximum permissible speed;
  - (3) refrigerant ammonia;
  - (4) year of manufacture;
  - (5) manufacturer's name;
  - (6) manufacturer's model number;
  - (7) manufacturer's identification number or serial number; and
  - (8) maximum permissible crankcase pressure.

### 5630.5620 EVAPORATIVE CONDENSERS.

- Subpart 1. **Generally.** This part applies to evaporative condensers that are applied to closed circuit ammonia refrigeration systems.
- Subp. 2. **Design criteria, evaporative condensers.** The design criteria for evaporative condensers is as follows:
  - A. Minimum design pressure must be 250 pounds per square inch gage (17.57 kilograms/cm<sup>2</sup> gage) (1724.0 kPa gage).
  - B. Evaporative condensers must be designed to withstand air velocities of 100 miles per hour (44.7 meters/s).
  - C. Fans, drives, and motors must be protected with screen or guards according to safety standards set by Occupational Safety and Health Division, Department of Labor and Industry, general requirements for all machines, and mechanical power transmission apparatus, chapter 5205.
  - D. Propeller, axial, or centrifugal fan speeds must not exceed the safe design speed recommended by the manufacturer for the temperature and nature of application.
  - E. Manufacturers producing ammonia evaporative condensers must provide the following data on the nameplate:
    - (1) manufacturer's name;
    - (2) year of manufacture;
    - (3) manufacturer's identification number;
    - (4) manufacturer's model number; and
    - (5) design pressure.

### 5230.5625 SHELL AND TUBE CONDENSERS.

- Subpart 1. **Generally.** This part applies to shell and tube condensers used in ammonia closed circuit refrigeration systems. Products covered by this part are horizontal and vertical shell and tube condensers with closed water passes and vertical shell and tube condensers with open water passes.
- Subp. 2. **Design criteria, shell and tube condensers.** The design criteria for shell and tube condensers are as follows:
  - A. Minimum design pressure must be 250 pounds per square inch gage (17.57 kilograms/cm<sup>2</sup> gage) (1724.0 kPa gage).
  - B. Pressure vessels must be provided with pressure relief protection according to part 5230.5655.
  - C. Adequate nozzles must be provided in the condenser shell for the attachment of pressure relief devices required in part 5230.5655.
  - D. The manufacturers producing shell and tube condensers must provide the following minimum data on the name plate:
    - (1) manufacturer's name;
    - (2) year of manufacture;
    - (3) national board number where applicable;
    - (4) serial number;
    - (5) American Society of Mechanical Engineers stamp;
    - (6) shell maximum allowable working pressure ..... at ..... temperature;
    - (7) tube maximum allowable working pressure ..... at ..... temperature; and
    - (8) manufacturer's model number.



**5230.5630 PRESSURE VESSELS.**

Subpart 1. **Generally.** This part applies to high pressure and low pressure vessels used in ammonia closed circuit refrigeration systems.

Subp. 2. **Design criteria, pressure vessels.** The design criteria for pressure vessels is as follows:

A. Minimum design pressure high side using water cooled or evaporative condensing must be 250 pounds per square inch (17.57 kilograms/cm<sup>2</sup> gage) (1724.0 kPa gage) and using air cooled condensing must be 300 pounds per square inch gage (21.09 kilogram/cm<sup>2</sup> gage) (2068.0 kPa gage).

B. Minimum design pressure low side must be 150 pounds per square inch gage (10.59 kilogram/cm<sup>2</sup> gage) (1034.0 kPa gage).

C. Pressure vessels exceeding six inches (152.4 millimeters) inside diameter must comply with the rules of American Society of Mechanical Engineers Boiler and Pressure Vessel Code, Section VIII, Division 1, covering the requirements for design, fabrication, inspection, and testing during construction of unfired pressure vessels.

D. Pressure vessels must be provided with adequate openings for the attachment of safety relief devices as required in part 5230.5655.

E. Manufacturers producing pressure vessels must provide the following minimum data on the nameplate:

- (1) manufacturer's name;
- (2) maximum allowable working pressure ..... at ..... temperature;
- (3) manufacturer's serial number;
- (4) year of manufacture;
- (5) national board number where applicable; and

(6) an additional pressure and temperature stamping is required for vessels used below minus 20 degrees Fahrenheit (minus 28 degrees centigrade) that are not impact tested.

**5230.5635 EVAPORATORS.**

Subpart 1. **Generally.** This part applies to evaporators that are used in ammonia closed circuit refrigeration systems.

Subp. 2. **Design criteria, forced air evaporator coil.** The design criteria for forced air evaporator coil is as follows:

A. minimum design pressure must be 150 pounds per square inch gage (10.54 kilograms/cm<sup>2</sup> gage) (1034.0 kPa gage);

B. fans, drives, and motors must be protected with screens or guards according to safety standards set by Occupational Safety and Health Division, Department of Labor and Industry, general requirement for all machines, and mechanical power transmission apparatus, chapter 5205;

C. propeller, axial, or centrifugal fan speeds must not exceed the safe design speed recommended by the manufacturer for the temperature and nature of the application;

D. manufacturers producing evaporator coils with fans and motors must provide the following minimum data on the nameplate:

- (1) manufacturer's name and trademark;
- (2) year of manufacture;
- (3) design pressure;
- (4) electrical full load amps for all components;
- (5) volts, hertz, and phase;
- (6) refrigerant ammonia;
- (7) identification number; and
- (8) model designation number.

Subp. 3. **Design criteria, shell and tube evaporators, flooded type.** The design criteria for flooded type refrigerant in shell is as follows:

**KEY: PROPOSED RULES SECTION** — Underlining indicates additions to existing rule language. ~~Strike outs~~ indicate deletions from existing rule language. If a proposed rule is totally new, it is designated "all new material." **ADOPTED RULES SECTION** — Underlining indicates additions to proposed rule language. ~~Strike outs~~ indicate deletions from proposed rule language.

## Proposed Rules

A. the shell side in the pressure vessel must be provided with adequate openings for the attachment of safety relief devices according to parts 5230.5660 and 5230.5665;

B. minimum design pressure must be 150 pounds per square inch gage (10.54 kilogram/cm<sup>2</sup> gage) (1034.0 kPa gage);

C. the manufacturer's producing shell and tube evaporators for refrigerants in the shell must provide the following minimum data on the nameplate:

(1) manufacturer's name;

(2) shell maximum allowable working pressure ..... at ..... temperature;

(3) tube maximum allowable working pressure ..... at ..... temperature;

(4) manufacturer's serial number;

(5) year of manufacture;

(6) national board number where applicable;

(7) American Society of Mechanical Engineers stamp;

(8) an additional pressure and temperature stamping is required for vessels used below minus 20 degrees Fahrenheit (minus 28.9 degrees centigrade) that are not impact tested; and

(9) manufacturer's model number.

Subp. 4. **Design criteria, shell and tube evaporators, direct expansion type with refrigerant in tubes.** The design criteria for direct expansion type with refrigerant in tubes is as follows:

A. tube must comply with rules of American Society of Mechanical Engineers Boiler and Pressure Vessel Code, section VIII, or American National Standards Institute B31.5, whichever applies;

B. tube side minimum design pressure must be 150 pounds per square inch gage (10.54 kilogram/cm<sup>2</sup> gage) (1034.0 kPa gage); and

C. manufacturers producing shell and tube evaporators for refrigerants in the tube must provide the following minimum data on the nameplate:

(1) manufacturer's name;

(2) shell maximum allowable working pressure ..... at ..... temperature;

(3) tube maximum allowable working pressure ..... at ..... temperature;

(4) manufacturer's serial number;

(5) year of manufacture;

(6) national board number where applicable;

(7) American Society of Mechanical Engineers stamp;

(8) an additional pressure and temperature stamping is required for vessels used below minus 20 degrees Fahrenheit (minus 29.9 degrees centigrade) that are not impact tested; and

(9) manufacturer's model number.

### 5230.5640 REFRIGERANT PUMP.

Subpart 1. **Generally.** This part applies to mechanical pumps used in closed circuit ammonia refrigeration systems.

Subp. 2. **Design criteria, refrigerant pumps.** The design criteria for refrigerant pumps is as follows:

A. A hydrostatic or differential pressure relief device or noncloseable vent pipe must be used for pressure protection of a liquid pump and its associated piping. The inlet connection for the relief device or vent pipe must be located on the pump casing or piping between the stop valves at the pump inlet and outlet, except that when a check valve is located between the pump and its outlet stop valve, the relief device or vent pipe inlet must be connected to the pipe between the discharge check valve and stop valve. No check valve may be installed that will isolate a liquid line solenoid in the pump discharge from the relief valve.

The relief device or vent pipe must connect either to the pump suction line upstream of the pump suction stop valve or to the vessel to which the pump suction is connected. This relief device or vent pipe must be external to the pump housing.

B. The pump casing minimum design pressure must be 150 pounds per square inch gage (10.54 kilogram/cm<sup>2</sup> gage) (1034.0 kPa gage) for low side service and 250 pounds per square inch gage (17.57 kilogram/cm<sup>2</sup> gage) (1724.0 kPa gage) for high side service with water cooled condensing and 300 pounds per square inch gage (21.09 kilogram/cm<sup>2</sup> gage) (2068.9 kPa gage) with air cooled condensing.

C. Pump drives and motors must be protected with screens or guards according to the standards of Occupational Safety and Health Division, Department of Labor and Industry, general requirements for all machines, and mechanical power transmission apparatus, chapter 5205.

D. A pump must be provided with controls that provide for the starting only when the pump is unloaded. Pumps must be installed with adequate electrical service and controls to start and run safely and operate in conformity with manufacturers recommendations.

E. Manufacturers producing ammonia pumps must permanently affix to the pump a nameplate providing the following minimum data on the nameplate:

- (1) manufacturer's name;
- (2) refrigerant ammonia;
- (3) maximum working pressure;
- (4) minimum allowable refrigerant temperature;
- (5) maximum speed of pump;
- (6) maximum horsepower of pump; and
- (7) manufacturer's model number.

### **5230.5645 REFRIGERATION CONTROL VALVES.**

Subpart 1. **Generally.** This part applies to control valves that contain or that are directly and automatically actuated by the ammonia refrigerant or its associated lubricating oil.

Products covered are solenoid valves, thermostatic expansion valves, automatic expansion valves, high side float valves, low side float valves, oil drain float valves, automatic liquid refrigerant drain valves, evaporator pressure regulators, downstream pressure regulators, hot gas bypass regulators, check valves, motorized valves, flow regulators, pilot operated and refrigerant pressure actuated condensing water regulators.

Refrigeration control valves contained within the refrigerant containing envelope for other equipment such as slide valves in screw compressors are not covered in this part.

Subp. 2. **Design criteria, refrigeration control valves.** The design criteria for refrigeration control valves are as follows:

A. The minimum design pressure for refrigeration control valves for water cooled condensing systems is 250 pounds per square inch gage (17.57 kilograms/cm<sup>2</sup> gage) (1724.0 kPa gage).

B. The minimum design pressure for refrigeration control valves for air cooled condensing systems is 300 pounds per square inch gage (21.09 kilogram/cm<sup>2</sup> gage) (2068.0 kPa gage).

C. The pressure requirements of this part apply to fluid and ambient temperatures of minus 20 degrees Fahrenheit (minus 28.9 degrees centigrade) to 450 degrees Fahrenheit (232.2 degrees centigrade).

D. For temperatures below minus 20 degrees Fahrenheit (minus 28.9 degrees centigrade), use American National Standards Institute B31.5, Code of Refrigerant Piping.

E. This part does not apply to any system with temperatures exceeding 450 degrees Fahrenheit (323.2 degrees centigrade).

F. Connection style, design, and fabrication for main and auxiliary connections must permit leaktight field installation without reducing the pressure requirements of this part and parts 5230.5900 to 5230.5960.

G. Manufacturers producing refrigeration control valves shall provide the following minimum data on the nameplate:

- (1) manufacturer's name;
- (2) serial number;
- (3) volts;
- (4) amperes;
- (5) hertz;

**KEY: PROPOSED RULES SECTION** — Underlining indicates additions to existing rule language. ~~Strike outs~~ indicate deletions from existing rule language. If a proposed rule is totally new, it is designated "all new material." **ADOPTED RULES SECTION** — Underlining indicates additions to proposed rule language. ~~Strike outs~~ indicate deletions from proposed rule language.

## Proposed Rules

---

---

- (6) manufacturer's model number;
- (7) pressure rating; and
- (8) ammonia service.

Subp. 3. **Functional test.** A completely assembled control valve must be given a bench test by the manufacturer using air or other suitable fluid that simulates the field performance of the moving parts of the valve in a manner that will determine that the completed device actually functions.

Subp. 4. **Leakage test.** A completely assembled control valve must be given a bench test by the manufacturer using air or other suitable fluid that enables observation of the leakage through the device when in a nominally closed position.

Subp. 5. **Pressure test.** A completely assembled control valve must be given a pressure test by the manufacturer at not less than the pressure required in parts 5230.6000. The entire envelope of the device must exhibit zero leakage under this pressure when subject to inspection under clean water or other suitable liquid or other leakage detection method of equal or greater sensitivity.

### 5230.5650 CONTROLS; ELECTRIC; PNEUMATIC.

Subpart 1. **Generally.** This part applies to sensing devices that initiate control pulses or signals applied for use in ammonia closed circuit refrigeration systems.

Subp. 2. **Design criteria.** The minimum high side design pressure is:

- A. Water cooled or evaporative condensing: 250 pounds per square inch gage (17.57 kilograms/cm<sup>2</sup> gage) (1724.0 kPa gage).
- B. Air cooled condensing: 300 pounds per square inch gage (21.09 kilograms/cm<sup>2</sup> gage) (2068.0 kPa gage). Minimum design pressure low side: 150 pounds per square inch gage (10.54 kilogram/cm<sup>2</sup> gage) (1034.0 kPa gage).

Subp. 3. **Nameplate data.** Manufacturers producing electrical and pneumatic controls must provide the following minimum data on the nameplate:

- A. manufacturer's name;
- B. volts;
- C. amperes;
- D. hertz;
- E. any special characteristics of a control device is to be noted either on the nameplate or in the accompanying literature; and
- F. manufacturer's model or serial number.

### 5230.5655 PRESSURE RELIEF DEVICES.

Subpart 1. **Generally.** This part applies to pressure relief devices installed on ammonia closed circuit refrigeration systems, for the purpose of safely relieving excess pressure due to fire or other abnormal conditions. Rupture members are not allowed under this chapter.

Subp. 2. **Standards for valves.** An ammonia refrigerating system must be protected by a pressure relief device and also must comply with the specific requirements in parts 5230.5900 to 5230.5960. They must be reseating type only. No rupture members shall be used.

Subp. 3. **Pressure actuation required.** A pressure relief device must be directly pressure actuated. Each part of a refrigerating system that can be valved off, and that contains one or more pressure vessels having internal diameters greater than three inches (76 millimeters) and containing liquid refrigerant, must be protected by a pressure relief device.

Subp. 4. **Stop valves.** Stop valves must not be located between the means of pressure relief and the part or parts of the system protected, except when the stop valve is of the three-way type connected in series to two parallel relief devices in a manner that both relief devices cannot be shut off from the system at the same time.

Subp. 5. **Pressure relief devices.** A pressure relief device must be connected above the liquid refrigerant level, and as nearly as practicable, directly to the pressure vessel or other parts of the system protected. The device must be installed so that it is readily accessible for inspection and repair. Condensers must be protected by relief devices on circuits that could be valved off.

Subp. 6. **Hydrostatic pressure relief.** Hydrostatic pressure relief devices must meet the requirements of part 5230.5945.

### 5230.5660 SETTING OF PRESSURE RELIEF DEVICES.

Subpart 1. **Pressure relief valve setting.** Pressure relief valves must be set to start to function at a pressure not more than the design pressure of the parts of the system protected.

Subp. 2. **Marking of relief devices.** A pressure relief valve for refrigerant containing components shall be set and sealed by the

manufacturer. A pressure relief valve must be marked by the manufacturer with the data required in the American Society of Mechanical Engineers Boiler and Pressure Vessel Code, Section VIII, Division 1, except that relief valves for systems with design pressures of 15 pounds per square inch gage (10.54 kilograms/cm<sup>2</sup> gage) (103.4 kPa gage) or less may be marked by the manufacturer with the pressure setting and capacity and comply with part 5230.5945.

### **5230.5665 PRESSURE VESSEL PROTECTION.**

Subpart 1. **Provision for pressure relief protection pressure.** Pressure vessels must be provided with pressure relief protection according to American Society of Mechanical Engineers Boiler and Pressure Vessel Code, Section VIII, Division 1. Piping requirements are governed by part 5230.5945.

Subp. 2. **Design criteria, pressure vessels of less than ten feet<sup>3</sup> (0.28 meter<sup>3</sup>) internal gross volume.** Except as specified in this part, a pressure vessel containing liquid ammonia refrigerant with internal gross volume less than ten feet<sup>3</sup> (0.28 meter<sup>3</sup>), which may be shut off from the other parts of a refrigerating system, must be protected by a pressure relief device having sufficient capacity to prevent the pressure in the vessel from rising more than ten percent above the setting of the pressure relief device.

Subp. 3. **Design criteria, pressure vessels of more than ten feet<sup>3</sup> (0.28 meter<sup>3</sup>) internal gross volume.** A pressure vessel ten feet<sup>3</sup> (0.28 meter<sup>3</sup>) gross or over must be protected by two parallel pressure relief devices connected to a three-way type stop valve as required by part 5230.5655. A pressure relief valve must have sufficient capacity to prevent the pressure in the pressure vessel from rising more than ten percent above the setting of the pressure relief valve.

Subp. 4. **High side to low side pressure relief protection, pressure relief valves discharging into low side of the system.** A single relief valve, not rupture member, of the required relieving capacity may be used on vessels of ten feet<sup>3</sup> (0.28 meter<sup>3</sup>) or over.

Subp. 5. **Parallel pressure relief devices on large vessels.** Except as specified in this part in cases where large pressure vessels containing liquid refrigerant require the use of two or more pressure relief devices in parallel to obtain the capacity required, the battery of pressure relief devices must be considered as a unit and as one pressure relief device.

Subp. 6. **Pressure relief protection for evaporator pressure vessels.** A pressure relief device for a pressure vessel used as, or as part of, an evaporator pressure vessel that has an internal diameter greater than six inches (152 millimeters) that is used in whole or in part as an evaporator and is insulated or installed in an insulated space, and that may be shut off by a valve from the other parts of the refrigerating system, must be protected by a pressure relief device according to this part. The requirement for a second parallel pressure relief valve does not apply.

Subp. 7. **Required capacity formula.** The minimum required discharge capacity of the pressure relief device for a pressure vessel must be determined by the following:

$$C = 0.5DL \text{ (lb/min.)} \quad C = 2.44DL \text{ (kg/min.)}$$

Where:

C = minimum required discharge capacity of the relief device in pounds of air per minute (kilograms per minute)

D = outside diameter of the vessel in feet (meters)

L = length of vessel in feet (meters)

When one pressure relief device is used to protect more than one pressure vessel, the required capacity is the sum of the capacities required for each pressure vessel.

Subp. 8. **Determining discharge capacity.** The rated discharge capacity of a pressure relief valve expressed in pounds of air per minute, must be determined according to American Society of Mechanical Engineers Boiler and Pressure Vessel Code, Section VIII, Division 1. Pipe and fittings between the pressure relief valve and the parts of the system it protects must have at least the area of the pressure relief valve inlet.

Subp. 9. **Discharge to a safe location.** Discharge of pressure relief devices on systems containing ammonia refrigerant must be to the outside of the building.

Subp. 10. **Discharge into low side.** Pressure relief valves may discharge into the low side of the system, if the pressure relief devices are of a type not significantly affected by back pressures and if the low side of the system is equipped with pressure relief devices. The relief devices on the low side of the system must have sufficient capacity to protect the pressure vessels that are relieved into the low side of the system, or to protect all pressure vessels on the low side of the system, whichever relieving capacity is the

**KEY: PROPOSED RULES SECTION** — Underlining indicates additions to existing rule language. ~~Strike outs~~ indicate deletions from existing rule language. If a proposed rule is totally new, it is designated "all new material." **ADOPTED RULES SECTION** — Underlining indicates additions to proposed rule language. ~~Strike outs~~ indicate deletions from proposed rule language.

# Proposed Rules

largest, as computed by the formula in subpart 7. The low side pressure relief device must be set and vented to the outside of the building according to this part.

Subp. 11. **Manifolding of relief discharges.** The size of the discharge pipe from the pressure relief device must not be less than the size of the pressure relief device outlet. The discharge from more than one relief device may be run into a common header, the area of which must not be less than the sum of the areas of the pipe connected to the common header, and as required by part 5230.5945.

Subp. 12. **Maximum discharge piping length.** The maximum length of the discharge piping permitted to be installed on the outlet of a pressure relief device must be determined as follows:

$$L = 9P_1^2 D^5 / 16C^2 \quad (L = 7 \times 10^{11} P_1^2 D^5 / C^2)$$

Where:

C = minimum required discharge capacity in pounds of air per minute (kilograms per minute)

D = internal diameter of pipe in inches (millimeters)

L = length of discharge pipe in feet (meters)

P<sub>1</sub> = rated pressure (pounds per square inch) x 1.10 + 14.7 rated pressure (kPa gage) x (1.10 + 101)

See part 5230.5665, subpart 13, for computation derived from the preceding formula.

Subp. 13. **Maximum equivalent length discharge piping (length in feet) for pressure-relief devices at various discharge capacities.**

A. Relief valve setting at 150 pounds per square inch:

| Stamped<br>Discharge<br>Capacity C<br>#Air/Min. | Relief Valve Setting 150 PSIG<br>Standard Wall Iron Pipe<br>Size in Inches |     |     |       |       |     |
|---|--|-----|-----|-------|-------|-----|
|   | 1/2  | 3/4 | 1   | 1-1/4 | 1-1/2 | 2   |
| 5   | 68   | 276 |     |       |       |     |
| 10  | 17   | 69  | 231 |       |       |     |
| 15  | 7  | 31  | 102 |       |       |     |
| 20  | 4  | 17  | 58  | 226   |       |     |
| 25  | 3  | 11  | 37  | 145   |       |     |
| 30  | 2  | 8   | 26  | 100   | 218   |     |
| 40  |  | 4   | 14  | 57    | 122   |     |
| 50  |  | 3   | 9   | 36    | 78    | 274 |
| 60  |  | 2   | 6   | 25    | 54    | 190 |
| 70  |  |     | 5   | 18    | 40    | 140 |
| 80  |  |     | 4   | 14    | 31    | 105 |
| 90  |  |     | 3   | 11    | 24    | 84  |
| 100   |  |     | 2   | 9     | 20    | 68  |
| 125   |  |     |     | 6     | 12    | 44  |
| 150   |  |     |     | 4     | 9     | 30  |
| 175   |  |     |     | 3     | 6     | 22  |
| 200   |  |     |     | 2     | 5     | 17  |

B. Relief valve setting at 200 pounds per square inch:

| Stamped<br>Discharge<br>Capacity C<br>#Air/Min. | Relief Valve Setting 200 PSIG<br>Standard Wall Iron Pipe<br>Size in Inches |     |     |       |       |   |
|---|--|-----|-----|-------|-------|---|
|   | 1/2  | 3/4 | 1   | 1-1/4 | 1-1/2 | 2 |
| 5   | 115  | 470 |     |       |       |   |
| 10  | 29   | 118 | 394 |       |       |   |
| 15  | 13   | 52  | 175 |       |       |   |
| 20  | 7  | 29  | 98  |       |       |   |
| 25  | 5  | 19  | 63  | 248   |       |   |

| Stamped<br>Discharge<br>Capacity C<br>#Air/Min. | Relief Valve Setting 200 PSIG<br>Standard Wall Iron Pipe<br>Size in Inches |     |    |       |       |     |
|---|--|-----|----|-------|-------|-----|
|   | 1/2  | 3/4 | 1  | 1-1/4 | 1-1/2 | 2   |
| 30  | 3  | 13  | 44 | 172   |       |     |
| 40  | 2  | 7   | 25 | 97    | 210   |     |
| 50  |  | 5   | 16 | 62    | 134   |     |
| 60  |  | 3   | 11 | 43    | 93    |     |
| 70  |  | 2   | 8  | 32    | 68    | 238 |
| 80  |  | 2   | 6  | 24    | 52    | 182 |
| 90  |  |     | 5  | 19    | 41    | 144 |
| 100   |  |     | 4  | 15    | 33    | 117 |
| 125   |  |     | 2  | 10    | 21    | 75  |
| 150   |  |     |    | 7     | 15    | 52  |
| 175   |  |     |    | 5     | 11    | 38  |
| 200   |  |     |    | 4     | 8     | 29  |

C. Relief valve setting at 250 pounds per square inch:

| Stamped<br>Discharge<br>Capacity C<br>#Air/Min. | Relief Valve Setting 250 PSIG<br>Standard Wall Iron Pipe<br>Size in Inches |     |     |       |       |     |
|---|--|-----|-----|-------|-------|-----|
|   | 1/2  | 3/4 | 1   | 1-1/4 | 1-1/2 | 2   |
| 5   | 176  |     |     |       |       |     |
| 10  | 44   | 179 |     |       |       |     |
| 15  | 20   | 80  | 267 |       |       |     |
| 20  | 11   | 45  | 150 |       |       |     |
| 25  | 7  | 29  | 96  |       |       |     |
| 30  | 5  | 20  | 67  | 263   |       |     |
| 40  | 3  | 11  | 37  | 147   |       |     |
| 50  | 2  | 7   | 24  | 94    | 204   |     |
| 60  |  | 5   | 17  | 66    | 142   |     |
| 70  |  | 4   | 12  | 48    | 104   |     |
| 80  |  | 3   | 9   | 37    | 80    |     |
| 90  |  | 2   | 7   | 29    | 63    | 220 |
| 100   |  | 2   | 6   | 24    | 51    | 178 |
| 125   |  |     | 4   | 15    | 33    | 114 |
| 150   |  |     | 3   | 11    | 23    | 79  |
| 175   |  |     | 2   | 8     | 17    | 58  |
| 200   |  |     | 2   | 6     | 13    | 44  |

D. Relief valve setting at 300 pounds per square inch:

| Stamped<br>Discharge<br>Capacity C<br>#Air/Min. | Relief Valve Setting 300 PSIG<br>Standard Wall Iron Pipe<br>Size in Inches |     |   |       |       |   |
|---|--|-----|---|-------|-------|---|
|   | 1/2  | 3/4 | 1 | 1-1/4 | 1-1/2 | 2 |
| 5   | 248  |     |   |       |       |   |
| 10  | 62   | 254 |   |       |       |   |
| 15  | 28   | 114 |   |       |       |   |

**KEY: PROPOSED RULES SECTION** — Underlining indicates additions to existing rule language. ~~Strike outs~~ indicate deletions from existing rule language. If a proposed rule is totally new, it is designated "all new material." **ADOPTED RULES SECTION** — Underlining indicates additions to proposed rule language. ~~Strike outs~~ indicate deletions from proposed rule language.

# Proposed Rules

| Stamped<br>Discharge<br>Capacity C<br>#Air/Min. | Relief Valve Setting 300 PSIG<br>Standard Wall Iron Pipe<br>Size in Inches |     |     |       |       |     |
|---|--|-----|-----|-------|-------|-----|
|   | 1/2  | 3/4 | 1   | 1-1/4 | 1-1/2 | 2   |
| 20  | 15   | 54  | 212 |       |       |     |
| 25  | 10   | 41  | 136 |       |       |     |
| 30  | 7  | 28  | 94  |       |       |     |
| 40  | 4  | 16  | 53  | 208   |       |     |
| 50  | 3  | 10  | 34  | 134   |       |     |
| 60  | 2  | 7   | 24  | 93    | 200   |     |
| 70  |  | 5   | 17  | 68    | 147   |     |
| 80  |  | 4   | 13  | 52    | 113   |     |
| 90  |  | 3   | 10  | 41    | 89    |     |
| 100   |  | 2   | 8   | 33    | 72    | 252 |
| 125   |  | 2   | 5   | 21    | 46    | 162 |
| 150   |  |     | 4   | 15    | 32    | 112 |
| 175   |  |     | 3   | 11    | 24    | 82  |
| 200   |  |     | 2   | 8     | 18    | 63  |

## 5230.5675 TESTING.

A refrigerant containing component must be tested and proved tight by the manufacturer at not less than the design pressure for which it is rated. Documentation of testing may be requested by the administrative authority.

## 5230.5680 CONSTRUCTION MATERIAL SELECTION; PIPE, VALVES, FITTINGS, ACCESSORIES.

Subpart 1. **Suitability, standards for materials.** Materials used in the construction of the equipment must be suitable for ammonia refrigerant at the coincident temperature and pressure to that the component may be subjected. No materials may be used that will deteriorate because of the presence of ammonia refrigerant or lubricating oil, or a combination of both, or any normal contaminant such as air or water. Where external surfaces of the equipment are exposed to corrosive effects of air, water, or other media, the exposed materials must be suitable for the application.

Subp. 2. **Ferrous materials.** Cast iron, malleable iron, nodular iron, steel, cast steel, and alloyed steel may be used as governed by American Society of Mechanical Engineers Boiler and Pressure Vessel Code, section VIII, division 1.

### Subp. 3. Other metals.

A. Cooper or zinc must not be used with ammonia.

B. Aluminum may be used in tubing, valves, and gaskets. It is the responsibility of the installer of an aluminum component to provide protection from electrolysis including di-electric isolation as needed.

C. Lead may be used for packing, gaskets, and joint compounds.

D. Tin and lead tin alloys may be used but their use is not allowed at temperatures below 14 degrees Fahrenheit (minus 10 degrees centigrade).

E. Consideration must be given to the possibility of stress corrosion cracking occurring in vessels and piping exposed to ammonia.

Subp. 4. **Nonmetallic materials.** Packings, glass, plastics, and rubber may be used if they conform to this part.

Subp. 5. **Components.** Components in direct contact with ammonia must not contain copper, brass, mercury, or alloys of these materials.

Subp. 6. **Pipe.** Pipe must be carbon steel that complies with this part, or a metallic material equal for safety and pressure and temperature rating and wall thickness. Nonmetallic pipe must not be used for ammonia service. Items A to F are the minimum standards for carbon steel pipe.

A. Diameter of pipe and minimum wall thickness of liquid lines, regardless of pressure:

- (1) 1-1/2 inches and smaller, American Society for Testing and Materials schedule 80 seamless pipe;
- (2) two inches through ten inches, American Society for Testing and Materials schedule 40 seamless pipe;
- (3) 12 inches through 24 inches, standard weight seamless pipe, three-eighths inch wall thickness minimum; and
- (4) exceeding 24 inches, standard weight pipe, three-eighths inch wall thickness minimum.



A liquid line through 24 inches must use American Society for Testing and Materials A-106 Grade B seamless piping.

B. Diameter of pipe and minimum wall thickness of vapor lines, regardless of pressure:

- (1) ten inches and smaller, American Society for Testing and Materials schedule 40 pipe; and
- (2) 12 inches and larger, standard weight pipe, three-eighths inch wall thickness minimum.

C. Threaded pipe must be American Society for Testing and Materials schedule 80 seamless minimum. Threaded fitting must be 2,000 pounds per square inch rating minimum.

D. Fittings must match pipe schedules. Threaded fittings must be forged steel. Socket weld fittings must be forged steel.

E. Carbon steel pipe must be:

- (1) American Society for Testing and Materials A-53 Grade B seamless;
- (2) American Society for Testing and Materials A-106 Grade B seamless; or
- (3) American Society for Testing and Materials A-53 Grade B (Electrical Resistance Welded).

F. Mill test reports must be provided for the inspector at the inspector's discretion to verify heat numbers on the pipe and to verify compliance with this part.

#### **5230.5690 ULTIMATE STRENGTH REQUIREMENT.**

A pressure containing component of an ammonia piping system other than pressure vessels, piping, pressure gages, and control mechanisms, must be listed either individually or as part of refrigeration equipment by an approved nationally recognized testing laboratory or must be designed, constructed, and assembled to have an ultimate strength sufficient to withstand at least three times the design pressure for which it is rated.

#### **5230.5700 BUILDING STRUCTURE AND MACHINE ROOM DESIGN.**

Subpart 1. **Room layout and access.** Machinery must be located in a manner that provides at least the minimum clearances for maintenance operations called for in the equipment manufacturer's instructions, and not less than 36 inches in front of access doors for components requiring service or maintenance.

Machinery installed in or on an exterior wall of a building, that is designed so that the controls must be serviced from the outside of the building, must be accessible as provided in this part.

Subp. 2. **Roof access to ammonia equipment.** Machinery located on the roof of any building must be accessible as provided in items A and B.

A. Access must be a stairway that complies with the requirements of the Minnesota State Building Code, chapters 1301 to 1365.

B. Access must be a stair leading to a scuttle or bulkhead in the roof having the equipment. The stair leading to the scuttle or bulkhead must be placed at an angle of not more than 60 degrees measured from the horizontal with flat treads at least six inches in width and a minimum length of 24 inches at the tread. No riser may be more than nine inches and handrails must be provided on both sides of the access stairs. The opening of the scuttle or bulkhead must not be less than nine square feet in area with the minimum dimension being two feet.

The required access must not be located in or pass through the elevator shaft or elevator machine room.

Subp. 3. **Roof access openings.** The roof access opening and equipment must be located with at least six feet of clearance from the edge of the roof or similar hazards, unless a suitable rail or guard at least 42 inches high is provided.

Subp. 4. **Convenience outlet.** A unit of equipment must have an accessible disconnect switch within sight line. A 20-ampere 110-120 volt AC ground-type convenience outlet must be installed on or adjacent to the unit or equipment. The outlet must have ground-fault circuit-interrupter protection and must not be connected to the equipment circuit.

Subp. 5. **Vibration elimination.** Machinery must be mounted to prevent excessive vibration from being transmitted to the building structure or to connected equipment.

Subp. 6. **Shutoff valves.** Valves must be readily accessible for operation and be clearly identified. Valves above floor level must be operated only from fixed platforms, ladders, or be chain operated. Isolating valves that stop the flow of liquid and discharge gas to the low side of the plant must be readily accessible and operable from the floor or a fixed platform.

**KEY: PROPOSED RULES SECTION** — Underlining indicates additions to existing rule language. ~~Strike outs~~ indicate deletions from existing rule language. If a proposed rule is totally new, it is designated "all new material." **ADOPTED RULES SECTION** — Underlining indicates additions to proposed rule language. ~~Strike outs~~ indicate deletions from proposed rule language.

## Proposed Rules

---

---

Subp. 7. **Condensation.** Machinery or piping that may cause condensation or drips must not be located over electrical facilities.

Subp. 8. **Building structure.** The building structure housing the machine room must be designed to provide adequate strength and rigidity to safely house and support compressors, accumulators, pumps, and other related equipment.

Subp. 9. **Equipment foundation.** The compressor and other heavy equipment foundations must be designed according to manufacturer's recommendations and other parameters dictated by subsoil and structural conditions and vibrations.

Subp. 10. **Roof structure.** The roof or ceiling structure must be designed to safely support the weight of suspended piping, oil traps, and other equipment.

Subp. 11. **Hub drains.** Adequate hub drains must be provided to properly dispose of wastewater according to the Minnesota State Plumbing Code, chapter 1355. The accumulation or the running of wastewater across the floor is not permitted.

Subp. 12. **Floor drains.** Adequate floor drains in a machinery room must be provided according to the Minnesota State Plumbing Code, chapter 1355, with all floors pitched toward the drains. A slick floor surface must be avoided.

Subp. 13. **Egress.** Machinery rooms and ammonia compressor rooms must be provided with a means of egress near each end of the room. Doors must swing outward and be provided with panic-type hardware.

Subp. 14. **Means of removal.** A means must be provided to allow for removal and replacement of any heavy motors or equipment from the building.

Subp. 15. **Separate location.** A separate location, separated from production or office facilities, is required for the machinery room.

### 5230.5705 OPEN FLAMES.

No open flames, or apparatus that may produce an open flame, may be installed in a machinery room where ammonia is used as a refrigerant. The use of matches, cigarette lighters, leak detectors, welding equipment, or other portable spark or current producing devices are not to be considered a violation of this part except that no uses of open flames or electrical current producing devices are permitted when ammonia or oil are being charged into or discharged from the system.

### 5230.5710 VENTILATION FOR MACHINERY ROOMS.

Subpart 1. **Scope.** Ventilation standards govern the ventilation protection of the equipment. Human occupancy standards are separate and are not covered in this part.

Subp. 2. **Ventilation to outside air.** An ammonia machinery room must be provided with means for ventilation to the outside air that complies with this part. The ventilation must consist of windows or doors opening to the outer air, of the size shown in this part or of mechanical means capable of removing the air from the room according to this part. The amount of ventilation for refrigerant removal purposes must be determined by the refrigerant content of the systems in the machinery room.

The ventilation system must provide sufficient hot weather ventilation to limit the temperature rise in the machinery room to a maximum of 20 degrees Fahrenheit (11.2 degrees centigrade) above outdoor ambient temperature. The temperature is to be measured five feet above floor level.

#### Subp. 3. **Required ventilation.**

A. The total required ventilation must be based on the requirements of subpart 9. One of the ventilation alternatives described in item B must be provided. Natural ventilation must be provided in all cases as required in item C.

B. One of the following mechanical ventilation alternatives must be provided.

(1) The room must be provided with a continuously operated, independent mechanical ventilation system. The room must be considered a hazardous class 1 location according to the Minnesota State Electrical Code. Failure of the mechanical ventilation system must initiate a supervised alarm so corrective action can be initiated. Ventilation requirements for air flow and duct area must be at least the minimums listed in subpart 9 for the quantity of refrigerant in the systems.

(2) The independent mechanical ventilation system must be actuated automatically by a vapor detector when the concentration of ammonia in the room exceeds 40,000 parts per million, 25 percent of lower explosive limit (LEL), and also be operable manually. The vapor detectors must also initiate a supervised alarm so corrective action can be initiated. Periodic tests of the detectors, alarms, or mechanical ventilation systems must be performed.

C. In addition to mechanical ventilation required in this part, the machinery room must also be provided with openings for natural ventilation as provided in subpart 9 for the quantity of refrigerant in the systems. Opening square footage may include windows and doorway openings. The opening area in subpart 9 must be the unobstructed, openable, free area of the windows and doors in the machinery room that open to the outside.

Subp. 4. **Air supply.** Air supply and return ducts used for machinery room ventilation must serve no other area or other purpose.

Subp. 5. **Mechanical ventilation.** Mechanical ventilation must consist of one or more power driven exhaust fans, which must be capable of removing from the refrigerating machinery room the amount of air specified in subpart 9. The inlet and outlet to the fan

or fans, or air duct connection must terminate outside of the building. When air ducts are used either on the inlet or discharge side of the fan, or fans, they must have an unobstructed free area not less than specified in subpart 9. Provision must be made for the introduction of tempered make-up air to replace that being exhausted in a volume equal to that being exhausted.

Subp. 6. **Air inlets.** The relative location of air inlets and discharge must be located as not to cause short circuiting.

Subp. 7. **Air discharge.** Air discharge must be directed to provide the best dispersion, taking into account natural air flow around the building, prevailing wind, and surrounding structures.

Subp. 8. **Water wash.** If dispersion is impractical, a water wash of the exhaust air may be used if approved by the building inspector. The water spray system must employ at least ten gallons per minute of water evenly distributed per 1,000 cubic feet per minute of exhausted air (1 meter<sup>3</sup>/s water per 750 meter<sup>3</sup>/s air).

**Subp. 9. Minimum air duct areas and openings.**

| Weight of refrigerant in system, lb. (kg) | Mechanical discharge of air, cfm. (m <sup>3</sup> /min) | Duct area sq. ft. (m <sup>2</sup> ) | Open areas of windows and doors, sq. ft. (m <sup>2</sup> ) |
|---|---|-------------------------------------|--|
| 20 (7)                                    | 150 (4.2)   | 1/4 (2.3 x 10 <sup>-2</sup> )       | 4 (37.2 x 10 <sup>-2</sup> )                               |
| 50 (22.7)                                 | 250 (7.1)   | 1/3 (3.1 x 10 <sup>-2</sup> )       | 6 (55.7 x 10 <sup>-2</sup> )                               |
| 100 (45.4)                                | 400 (11.3)  | 1/2 (4.6 x 10 <sup>-2</sup> )       | 10 (92.9 x 10 <sup>-2</sup> )                              |
| 150 (68.0)                                | 550 (15.6)  | 2/3 (6.2 x 10 <sup>-2</sup> )       | 12-1/2 (1.16)  |
| 200 (90.7)                                | 680 (19.2)  | 2/3 (6.2 x 10 <sup>-2</sup> )       | 14 (1.30)  |
| 250 (113)                                 | 800 (22.6)  | 1 (9.3 x 10 <sup>-2</sup> )         | 15 (1.39)  |
| 300 (136)                                 | 900 (25.5)  | 1 (9.3 x 10 <sup>-2</sup> )         | 17 (1.58)  |
| 400 (181)                                 | 1,100 (31.2)  | 1-1/4 (11.6 x 10 <sup>-2</sup> )    | 20 (1.86)  |
| 500 (227)                                 | 1,275 (36.1)  | 1-1/4 (11.6 x 10 <sup>-2</sup> )    | 22 (2.04)  |
| 600 (272)                                 | 1,450 (41.1)  | 1-1/2 (13.9 x 10 <sup>-2</sup> )    | 24 (2.23)  |
| 700 (318)                                 | 1,630 (46.2)  | 1-1/2 (13.9 x 10 <sup>-2</sup> )    | 26 (2.42)  |
| 800 (363)                                 | 1,800 (51.0)  | 2 (18.6 x 10 <sup>-2</sup> )        | 28 (2.60)  |
| 900 (408)                                 | 1,950 (55.2)  | 2 (18.6 x 10 <sup>-2</sup> )        | 30 (2.79)  |
| 1,000 (454)                               | 2,050 (58.0)  | 2 (18.6 x 10 <sup>-2</sup> )        | 31 (2.88)  |
| 1,250 (567)                               | 2,250 (63.7)  | 2-1/4 (20.9 x 10 <sup>-2</sup> )    | 33 (3.06)  |
| 1,500 (680)                               | 2,500 (70.8)  | 2-1/4 (20.9 x 10 <sup>-2</sup> )    | 37 (3.44)  |
| 1,750 (794)                               | 2,700 (76.5)  | 2-1/4 (20.9 x 10 <sup>-2</sup> )    | 38 (3.53)  |
| 2,000 (907)                               | 2,900 (82.1)  | 2-1/4 (20.9 x 10 <sup>-2</sup> )    | 40 (3.72)  |
| 2,500 (1,134)                             | 3,300 (93.4)  | 2-1/2 (23.2 x 10 <sup>-2</sup> )    | 43 (4.00)  |
| 3,000 (1,361)                             | 3,700 (105)   | 3 (27.9 x 10 <sup>-2</sup> )        | 48 (4.46)  |
| 4,000 (1,814)                             | 4,600 (130)   | 3-3/4 (34.8 x 10 <sup>-2</sup> )    | 55 (5.11)  |
| 5,000 (2,268)                             | 5,500 (156)   | 4-1/2 (41.8 x 10 <sup>-2</sup> )    | 62 (5.76)  |
| 6,000 (2,722)                             | 6,300 (178)   | 5 (46.4 x 10 <sup>-2</sup> )        | 68 (6.32)  |
| 7,000 (3,175)                             | 7,200 (204)   | 5-1/2 (51.1 x 10 <sup>-2</sup> )    | 74 (6.87)  |
| 8,000 (3,629)                             | 8,000 (226)   | 5-3/4 (53.4 x 10 <sup>-2</sup> )    | 80 (7.43)  |
| 9,000 (4,082)                             | 8,700 (246)   | 6-1/4 (58.1 x 10 <sup>-2</sup> )    | 85 (7.90)  |
| 10,000 (4,536)                            | 9,500 (269)   | 6-1/2 (60.4 x 10 <sup>-2</sup> )    | 90 (8.36)  |
| 12,000 (5,443)                            | 10,900 (309)  | 7 (65.0 x 10 <sup>-2</sup> )        | 100 (9.29)   |
| 14,000 (6,350)                            | 12,200 (345)  | 7-1/2 (69.7 x 10 <sup>-2</sup> )    | 109 (10.1)   |
| 16,000 (7,258)                            | 13,300 (377)  | 7-3/4 (72.0 x 10 <sup>-2</sup> )    | 118 (11.0)   |
| 18,000 (8,165)                            | 14,300 (405)  | 8 (74.3 x 10 <sup>-2</sup> )        | 125 (11.6)   |
| 20,000 (9,072)                            | 15,200 (430)  | 8-1/4 (76.6 x 10 <sup>-2</sup> )    | 130 (12.1)   |
| 25,000 (11,340)                           | 17,000 (481)  | 8-3/4 (81.3 x 10 <sup>-2</sup> )    | 140 (13.0)   |
| 30,000 (13,608)                           | 18,200 (515)  | 9 (83.6 x 10 <sup>-2</sup> )        | 145 (13.5)   |
| 35,000 (15,876)                           | 19,400 (549)  | 9-1/4 (85.9 x 10 <sup>-2</sup> )    | 150 (13.9)   |
| 40,000 (18,144)                           | 20,500 (580)  | 9-1/2 (88.2 x 10 <sup>-2</sup> )    | 155 (14.4)   |
| 45,000 (20,412)                           | 21,500 (609)  | 9-3/4 (90.6 x 10 <sup>-2</sup> )    | 160 (14.9)   |

**KEY: PROPOSED RULES SECTION** — Underlining indicates additions to existing rule language. ~~Strike outs~~ indicate deletions from existing rule language. If a proposed rule is totally new, it is designated "all new material." **ADOPTED RULES SECTION** — Underlining indicates additions to proposed rule language. ~~Strike outs~~ indicate deletions from proposed rule language.

## Proposed Rules

### 5230.5820 ELECTRICAL STANDARDS FOR AMMONIA INSTALLATIONS.

Subpart 1. **Installation standards.** Electrical equipment and wiring must be approved by the electrical inspector and installed consistent with the standards of the Minnesota State Electrical Code.

Subp. 2. **Electrical material.** Heavy-wall galvanized conduit must be used in machinery rooms.

Subp. 3. **Machinery room lighting.** A machinery room must be equipped with light fixtures to provide a minimum 30 foot-candles (322.8 lumen per meter<sup>2</sup>) at the working level 36 inches above the floor or platform. Fixtures must be designed to prevent unauthorized replacement of the lights with lights of lesser voltage. Each unit of equipment must have an accessible disconnect switch within sight line. A 20-ampere 110-120 volt AC ground-type convenience outlet must be installed on or adjacent to the unit or equipment in the machinery room. The outlet must have ground-fault circuit-interrupter protection and must not be connected to the equipment circuit.

### 5230.5825 INSULATION.

Subpart 1. **Basic requirements.** Piping that operates at a temperature of less than 60 degrees Fahrenheit or more than 105 degrees Fahrenheit must be insulated with at least one inch of a suitable material having a thermal resistance of at least R4 to R4.6 per inch of thickness on a flat surface at a mean temperature of 75 degrees Fahrenheit except as provided in item A or B.

A. compressor discharge piping to the condenser does not require insulation if it is properly guarded to prevent accidental contact; or

B. control valves located inside or outside the machinery room do not require insulation if suitable means is provided for water (condensate) to be drained or disposed of safely consistent with the Minnesota State Plumbing Code, chapter 1355.

Subp. 2. **Prevention of condensation.** Suction lines, accumulators, surge drums, and similar surfaces that operate at or below the dew point temperature must be insulated to prevent the accumulation of condensation on surfaces adjacent to the piping according to the following minimum:

40 to 60 degrees = one inch of insulation

below 39 degrees = one and one-half inch of insulation

Subp. 3. **Hot piping.** Exposed hot water or hot gas discharge piping within seven feet of the floor or working platform or within 15 inches measured horizontally from stairways, ramps, or fixed ladders must be covered with an insulating material, or guarded in a manner to prevent contact with the piping.

### 5230.5915 PIPING JOINTS.

Subpart 1. **Design standards.** Piping joints must be designed for ammonia service. Joints must be designed for the pressure temperature and mechanical strength requirements of ammonia service and items A to E.

A. One and one-quarter inch and smaller joints may be threaded or welded. Threaded pipe must be American Society for Testing and Materials schedule 80 seamless. Threaded fittings must be 2,000 pounds per square inch rating. Threaded fittings must be forged steel.

B. Joints one and one-half inch and larger must be welded. Fittings must match pipe schedule and material. Welded pipe one and one-half inch and smaller must be jointed with the use of socket weld fittings of at least 3,000 pounds per square inch ratings or butt weld fittings of the same wall thickness and material as the pipe. Socket weld fittings must be forged steel.

C. Flanges must be a tongue and groove type rated at least 300 pounds per square inch and designed for ammonia service and system pressure.

D. Gaskets must be designed for ammonia service and system pressure.

E. Unions must be at least 3,000 pounds per square inch forged steel ground joint unions, be used only for three quarters inch and smaller pipe, and must be socket weld.

Subp. 2. **Branch, run-outs, laterals, and saddles.** If the main piping is two inches and smaller, or the branch or run-out is two inches and smaller, branch or lateral connections must be forged steel TEE fitting, forged steel WELD-O-LETT™ or THREAD-O-LETT™, or engineering equivalent of at least 3,000 pounds per square inch rating. Engineering equivalency must be based on proper documentation signed by a registered professional engineer.

Where the main piping exceeds two inches, branch or lateral connections must be made by forged steel TEE fitting, be forged steel WELD-O-LETT™, or THREAD-O-LETT™ of at least 3,000 pounds per square inch rating; or in cases where the branch exceeds two inches (further providing that a branch lateral or saddle is two pipe sizes smaller than the main piping it is connected to) the connection may be made by the use of a saddle or lateral connection that complies with the requirements of this part.

Branches or runouts the same size as the main must be connected using forged steel TEE fittings.

Welding of saddles and laterals must result in a match of the inside diameters of the main and the branch and result in proper fusion

through the weld and must be subjected to nondestructive testing including radiography at the discretion of the administrative authority.

The costs of nondestructive testing for labor and materials and all testing media must be at the expense of the installing contractor.

Subp. 3. **Welding of large joints.** Two inches and larger welded joints must be butt weld fittings that are of the same schedule as the piping and in no case less than the same wall thickness and material of the pipe.

Subp. 4. **Maximum pressure service.** Pipe, fittings, and components for ammonia service must be used only for pressure service that is 90 percent or less of component design working pressure.

Subp. 5. **Components.** The assembly of the various components, whether done in a shop or as a field erection, must be done so that the completely erected piping and equipment conform with the requirements of this chapter.

#### **5230.5925 WELDING.**

Subpart 1. **Certification.** Welders must be certified under a welding procedure for the job. An employer is responsible for the welding done by personnel of its organization, and must conduct any required tests and maintain necessary records of the tests.

Subp. 2. **Scope.** This part applies to the installation and repair of ammonia piping system and component parts, such as pipe, hangers, braces, and supports.

Subp. 3. **Welding qualifications.** Standard qualifications for welding procedures, welders, and welding operators made according to American Society of Mechanical Engineers Boiler and Pressure Vessel Code, section IX, qualify for work under this part.

Subp. 4. **Welding qualifications for component parts.** Standard qualifications for welding procedures, welders, and welding operators made according to American Welding Society, Structural Welding Code-Steel, standards also qualify the welder for welding component parts such as hangers, braces, and supports.

Subp. 5. **Expiration of welder certification.** Welders certifications expire after three years from the original date of certification. Welders certified by the welding procedures specification must recertify by performing the original welding test used for certification in that process.

Subp. 6. **Document submission requirements.** Welding on projects for ammonia piping systems must have welding procedure specification and procedure qualification records submitted for each project with the permit applications for approval before work begins.

Subp. 7. **Weld procedure and qualification requirements.** No welding may be performed on ammonia piping systems without welding procedures specification, and welding procedures qualification. Welding performed on ammonia piping systems must be performed using only welders properly certified according to the welding procedure submitted.

Subp. 8. **Welding requirements.** Welding of ammonia piping systems components must meet the requirements of the welding procedures specification and procedure qualification record.

Subp. 9. **Welding procedures required.** A certified welding procedure for each project must be a welding procedure specification supported by the procedure qualification record.

Subp. 10. **Evaluation standards.** The welding procedure specification and procedure qualification record must be objectively evaluated by and acceptable to the administrative authority.

Subp. 11. **Welders certification.** Welders must be certified according to the certified welding procedure for that project.

Subp. 12. **Documentation required.** Welding for ammonia piping systems must be supported by the mandatory documents of welding procedure specification, welding procedure qualification, and procedure qualification record. These documents must be available at the work site.

Subp. 13. **Weld identification.** Welds on ammonia piping must be identifiable.

Subp. 14. **Welder identification number and log requirement.** A welder certified for a project must be assigned an identification number unique to that welder. Welds must be stamped or marked. The use of a welding log is required.

Subp. 15. **Contractor responsibility.** The contractor is responsible for establishing and retaining the needed documents to conform to the requirements of this part.

Subp. 16. **Guide bend test.** When the welding processes in item A or B are indicated on the welding procedure specification, the guide bend test is required when certifying the welding procedure specification and for individual welder qualification:

**KEY: PROPOSED RULES SECTION** — Underlining indicates additions to existing rule language. ~~Strike outs~~ indicate deletions from existing rule language. If a proposed rule is totally new, it is designated "all new material." **ADOPTED RULES SECTION** — Underlining indicates additions to proposed rule language. ~~Strike outs~~ indicate deletions from proposed rule language.

## Proposed Rules

- A. gas metal arc welding; or
- B. submerged arc welding.

The use of a guide bend test-jig is mandatory. The jig must be approved by the administrative authority.

A guide bend test consists of at least two coupons for each of the following: face bend, root bend, and side bend, or four side bends. The use of part 5230.1080, subpart 6, shall apply provided the requirements of this part are met.

Subp. 17. **Nondestructive testing.** The administrative authority may at its discretion order the use of nondestructive testing including radiography for inspection of the welding of ammonia piping systems. The costs of nondestructive testing for labor and materials and all testing media shall be at the expense of the installing contractor.

Subp. 18. **Repair welds.** Repair welds must meet the requirements of this part.

### 5230.5930 STOP VALVES.

Subpart 1. **Location of valves.** Stop valves for stopping flow of refrigerant for service must be located at the inlet and outlet of each component of the system, including:

- A. compressor;
- B. condenser;
- C. receiver;
- D. evaporator; and
- E. vessels, pumps, and those items needed for safe and proper operation of the system.

Subp. 2. **Valve design.** Manual valves must be designed for ammonia service and made of materials suitable for ammonia service and shall be angle or globe type. Valves must be capable of backseating. Quarter turn valves must not be used for ammonia service.

Subp. 3. **Number and placement of stop valves.** Sufficient stop valves must be installed to expedite service and repair and to allow isolation of ammonia components by emergency responders.

### 5230.5935 MISCELLANEOUS MATERIALS.

Subpart 1. **Scope.** Standards for miscellaneous materials are as stated in this part.

Subp. 2. **Gauge lines.** Gauge lines for ammonia not more than one-fourth inch outside diameter or less must be constructed of materials that comply with the requirements of this chapter. These may be compressive type fittings, such as "SwageLock™," or 2,000 pounds per square inch rated engineering equivalent. Engineering equivalency must be based on proper documentation signed by a registered professional engineer.

Subp. 3. **Accessories.** Factory assembled accessories may use tubing of a larger size which must be of a material designed for ammonia service and joined by compressive type fittings, such as "Swagelock™," or engineering equivalent based on proper documentation signed by a registered professional engineer, or 2,000 pounds per square inch rated equivalent.

### 5230.5940 PIPING HANGERS AND SUPPORTS.

Subpart 1. **Hangers and supports specifications.** The supports must carry the weight of the pipe, including contents and insulation, and, if necessary, provide sway bracing to minimize vibration.

Subp. 2. **Components.**

- A. The required maximum spacing of hangers and minimum hanger rod size for steel pipe:

#### Nominal pipe

| Maximum Size          | Minimum Rod Space | Diameter |
|-----------------------|-------------------|----------|
| Up to 1 inch          | 7 feet            | 3/8 inch |
| 1-1/4 to 1-1/2 inches | 9 feet            | 3/8 inch |
| 2 inches              | 10 feet           | 3/8 inch |
| 3 inches              | 12 feet           | 1/2 inch |
| 3-1/2 inches          | 13 feet           | 1/2 inch |
| 4 inches              | 14 feet           | 5/8 inch |

**KEY: PROPOSED RULES SECTION** — Underlining indicates additions to existing rule language. ~~Strike outs~~ indicate deletions from existing rule language. If a proposed rule is totally new, it is designated "all new material." **ADOPTED RULES SECTION** — Underlining indicates additions to proposed rule language. ~~Strike outs~~ indicate deletions from proposed rule language.

| Maximum Size | Minimum Rod Space | Diameter |
|--------------|-------------------|----------|
| 5 inches     | 16 feet           | 5/8 inch |
| 6 inches     | 17 feet           | 3/4 inch |
| 8 inches     | 19 feet           | 7/8 inch |
| 10 inches    | 22 feet           | 7/8 inch |
| 12 inches    | 23 feet           | 7/8 inch |

B. This chart represents mandatory maximum requirements for hanger rod loading. Maximum loads are in pounds at 650 degrees Fahrenheit based on threaded hot rolled steel conforming to American Society for Testing and Materials A-107.

| Rod Diameter in Inches | Max Load in pounds |
|------------------------|--------------------|
| 3/8                    | 610                |
| 1/2                    | 1,130              |
| 5/8                    | 1,810              |
| 3/4                    | 2,710              |
| 7/8                    | 3,770              |
| 1                      | 4,960              |
| 1-1/8                  | 6,230              |
| 1-1/4                  | 8,000              |
| 1-1/2                  | 11,630             |
| 1-3/4                  | 15,700             |
| 2                      | 20,700             |
| 2-1/4                  | 27,200             |
| 2-1/2                  | 33,500             |
| 2-3/4                  | 41,600             |
| 3                      | 50,600             |
| 3-1/4                  | 60,500             |

**5230.5945 PRESSURE RELIEF PROTECTION.**

Subpart 1. **Scope.** A refrigeration system must be protected by a pressure relief device.

Subp. 2. **Protection required.** Refrigeration systems must be protected according to the requirements of this part and part 5230.5660.

Subp. 3. **Discharge piping.** The extremity of the relief valve discharge line when relieved to atmosphere must be above the roof, and not within 25 feet (7.6 meters) of any window, ventilation intake, or personnel exit, and must be fitted with suitable rain protection or an ammonia diffuser. A drip pocket the size of the discharge pipe and at least 24 inches (610 millimeters) in length must be installed below a vertical riser in the discharge pipe, and it must be fitted with a drain plug or valve.

Subp. 4. **Relief piping and devices requirements.** Relief devices and relief piping must meet the requirements of parts 5230.5900 to 5230.5960. A shutoff valve must not be installed in the relief piping between the device and atmosphere.

Subp. 5. **Liquid pressure relief device.** A liquid pressure relief device to relieve hydrostatic pressure to another part of the system must be used on that portion of the liquid containing parts of the system that can be isolated from the system during operation or service and that may be subjected to dangerous pressures from hydrostatic expansion of the contained liquid due to temperature rise. It is the installers responsibility to provide hydrostatic relief protection.

Subp. 6. **Common atmospheric discharge piping.** When connecting relief valves of different pressure settings into a common atmospheric discharge pipe, the size and maximum equivalent length of the discharge pipe must be governed by the sum of the rated discharge capacities of all relief valves discharging into the pipe, at the lowest pressure setting of any relief valve discharging into the pipe.

**5230.5950 INSTALLATION REQUIREMENTS.**

Subpart 1. **Foundations and supports.** Foundations and supports for condensing units or compressor units must be of substantial and noncombustible construction.

Subp. 2. **Moving machinery.** Moving machinery must be guarded according to Occupational Safety and Health safety standards.

Subp. 3. **Clearances.** Clear space adequate for inspection and servicing of condensing units or compressor units must be provided.

**KEY: PROPOSED RULES SECTION** — Underlining indicates additions to existing rule language. ~~Strike outs~~ indicate deletions from existing rule language. If a proposed rule is totally new, it is designated "all new material." **ADOPTED RULES SECTION** — Underlining indicates additions to proposed rule language. ~~Strike outs~~ indicate deletions from proposed rule language.

## Proposed Rules

---

Subp. 4. **Enclosures.** Condensing units or compressor units with enclosures must be readily accessible for servicing and inspection.

Subp. 5. **Water supply and discharge.** Water supply and discharge connections must be made according to safety and health standards of the Minnesota State Plumbing Code, chapter 1355, and the water pollution standards of the Minnesota Pollution Control Agency, contained in chapter 7050.

Subp. 6. **Discharge lines.** Discharge water lines must not be directly connected to the waste or sewer systems. The waste or discharge from this equipment must be through an approved air gap and trap according to safety and health standards of the Minnesota State Plumbing Code, chapter 1355.

Subp. 7. **Illumination.** Illumination adequate for inspection and servicing of condensing units or compressor units must be provided.

Subp. 8. **Minnesota State Electrical Code.** Electrical equipment and wiring must be installed according to the Minnesota State Electrical Code.

Subp. 9. **Air ducts in class T construction.** Standards for air duct systems of air conditioning equipment for human comfort using refrigeration are not covered in this chapter. Air ducts passing through a class T machinery room must be of vapor tight construction and must have no openings in the room.

Subp. 10. **Joints and refrigerant containing parts in air ducts.** Joints and refrigerant containing parts of a refrigeration system located in an air duct carrying conditioned air to and from an occupied space must be constructed to withstand a temperature of 700 degrees Fahrenheit (353.3 degrees centigrade) without leakage into the air stream.

Subp. 11. **Piping joints to be visible.** Refrigerant pipe joints erected on a premise must be exposed to view for visual inspection before being covered or enclosed.

### 5230.5960 FOUNDATIONS AND EQUIPMENT.

Subpart 1. **Supports and foundations.** Supports and foundations must be adequate to prevent excessive vibration and movement of the equipment.

Subp. 2. **Manufacturer's recommendations.** The supports must conform to the manufacturer's recommendations.

### 5230.6100 SYSTEM TESTING.

Subpart 1. **Standards.** A contracting pipefitter is responsible for system tightness and system testing to assure tightness. The contracting pipefitter is responsible for system operation and system testing to assure proper safe operation.

Subp. 2. **Sequential testing.** A testing program for ammonia refrigeration systems must be designed to assure a tight system that will operate without any appreciable loss of refrigerant, a system that will be reliable with respect to the electric components, and a system that will function according to the design with respect to controls and capacities. The test requirements of subparts 3 to 5 must be done sequentially to meet the requirements of this part.

Subp. 3. **Field tests.** Upon the complete installation of an ammonia system, the system must be tested for leaks. The high side must be tested at 250 pounds per square inch gage (17.57 kilograms/cm<sup>2</sup> gage) (1724.0 kPa gage) for water cooled or evaporative cooled systems, 300 pounds per square inch gage (21.09 kilograms/cm<sup>2</sup> gage) (1034.0 kPa gage) for air cooled systems. The low side must be tested at 150 pounds per square inch gage (10.54 kilograms/cm<sup>2</sup> gage) (1034.0 kPa gage). Test duration must be a minimum of 12 hours. There is no permissible pressure loss during the time of this test. Before testing, refrigeration compressors, liquid pumps, and pressure switches must be valved off and isolated from any test pressures. Safety relief valves must be removed and openings capped or plugged. All solenoid, pressure regulating, check, or other control valves must be opened by their manual lifting stems. Other valves must be opened except those leading to the atmosphere. Valves leading to atmosphere must be capped or locked shut. The system's ammonia compressor must not be used for the pressure test.

Subp. 4. **Test medium and pressure testing.** Oxygen or any combustible gas or combustible mixture of gases must not be used within the system for testing. Carbon dioxide or halocarbon (CFC) refrigerants must not be used as a testing gas in an ammonia system. Dry nitrogen or air must be used to raise the pressure in the ammonia system to the proper level of the test. The gas must be put in the system through the charging valve or any other suitable opening using the necessary regulators and relief devices. Leaks must be repaired and defective material be replaced. After a system is thoroughly tested, the valves on the lower part of the system must be opened. The valves must be quickly opened wide.

Subp. 5. **Leak testing.** Upon completion of the pressure testing and evacuation to minimum ten inches (25.40 centimeters) mercury (Hg) vacuum, sufficient ammonia must be introduced into the system and the system subjected to 100 pounds per square inch gage (7.03 kilograms/cm<sup>2</sup> gage) (689.5 kPa gage) ammonia pressure. During this period, the system must be carefully inspected for leaks using sulphur tapers or litmus paper.

A. Two ammonia gas masks must be available during this test in a readily accessible location immediately adjacent to the testing location in case of an emergency.

B. If any leaks are found, they must be repaired and rechecked before the system can be considered tight. No repairs may be



made to welded joints while the system is under pressure. The costs of testing for labor and materials and all testing media must be at the expense of the installing contractor.

Subp. 6. **Witnessed test.** Witnessed tests under this part may be witnessed by the administrative authority.

#### **5230.6110 SIGNS.**

Subpart 1. **Content of signs.** An ammonia piping system erected on a premises must be provided with an easily legible, readily accessible permanent metal sign that complies with subpart 2 and is securely attached to the piping. The sign must indicate the name and address of the installer, the total number of pounds (kilograms) weight of ammonia refrigerant required in the system for normal operations, and the field test pressure applied.

Subp. 2. **Equipment signs.** Metal signs for ammonia piping systems must be provided and have letters at least one-half inch (one millimeter) in height that designate:

- A. the systems main shutoff valve king valve;
- B. hot gas bypass;
- C. liquid shutoff valves;
- D. the main shutoff valves to each vessel;
- E. main steam or electrical control;
- F. equipment disconnects;
- G. remote control switches; and
- H. the pressure limiting device.

On all exposed high pressure and low pressure piping in each room where installed and adjacent to all valves must be signs, as specified in items A to H, with the name of the refrigerant and letters "HP" or "LP" and high side or low side, the piping painted in the complying colors, and arrows showing flow direction.

Subp. 3. **Pipe identification.** Pipe colored marking for the ammonia piping system must be yellow with black letters and black arrows. Signs must be yellow with black letters. Piping identification must conform with American National Standards Institute, American Society of Mechanical Engineers standard A13.1, standard for the identification of piping.

#### **5230.6115 REFRIGERANTS.**

Subpart 1. **Charging and discharging refrigerants.** When refrigerant is added to a system, it must be charged into the low pressure side of the system. Any point on the downstream side of the main liquid line stop valve is part of the low pressure side when operating with the stop valve in the closed position. No service container may be left connected to a system except while charging or withdrawing refrigerant. Heat must not be applied to the cylinder.

Subp. 2. **Transfer to approved cylinder.** Refrigerants withdrawn from refrigerating systems must be transferred only to containers approved by a nationally recognized testing laboratory.

Subp. 3. **Care of containers.** Containers used for refrigerants withdrawn from a refrigerating system must be carefully weighed each time they are used for this purpose. The containers must not be filled in excess of the rated capacity weight for the containers and the type of refrigerant used.

Subp. 4. **Maximum storage.** Refrigerant stored in a machinery room must be not more than 300 pounds (136 kilograms) weight, in addition to the charge in the system. The refrigerant must be stored in a permanently attached receiver and only in storage containers approved by the administrative authority.

#### **5230.6120 MASKS OR HELMETS.**

Subpart 1. **Location.** At least two masks or helmets must be provided at a readily accessible location immediately adjacent to each machinery room.

Subp. 2. **Approved masks.** Only complete helmets or masks suitable for ammonia must be used and they must be kept in a suitable readily accessible cabinet immediately outside the machinery room or other readily accessible location.

**KEY: PROPOSED RULES SECTION** — Underlining indicates additions to existing rule language. **Strike outs** indicate deletions from existing rule language. If a proposed rule is totally new, it is designated "all new material." **ADOPTED RULES SECTION** — Underlining indicates additions to proposed rule language. **Strike outs** indicate deletions from proposed rule language.

## Proposed Rules

---

Subp. 3. **Canister/mask renewal.** Canisters or cartridges of helmets or masks must be renewed immediately after having been used or the seal broken and, if unused, the canisters must be renewed not later than the date noted on the canister labels.

Subp. 4. **Reference standard.** For standards for masks refer to American National Standards Institute, standard Z87.1, practice for occupational and educational eye and face protection.

### 5230.6125 MAINTENANCE AND OPERATION.

Subpart 1. **Maintenance.** Ammonia refrigerating systems must be maintained by the user in a clean condition, free from accumulations of oily dirt, waste, and other debris, and must be kept accessible at all times.

Subp. 2. **System responsibility.** It is the responsibility of the person in charge of the premises on which an ammonia piping system containing more than 50 pounds (22.68 kilograms) weight of ammonia is installed, to conspicuously place in a readily accessible location as near as practicable to the ammonia compressor, a sign that complies with part 5230.6110 and gives clearly written directions for the operation of the system, including precautions to be observed in case of a breakdown or leak as follows:

- A. instruction for shutting down the system in case of emergency;
- B. the name, address, and day and night telephone numbers to obtain service;
- C. the name, address, and telephone number of the administrative authority, and instructions to notify the authority immediately in case of emergency;
- D. an ammonia incident action plan that includes the following minimum instructions for dealing with an ammonia leak:
  - (1) sound an alarm;
  - (2) notify fire department/emergency responders immediately;
  - (3) muster plant personnel;
  - (4) isolate area;
  - (5) secure supply line to leak area;
  - (6) secure return line from leak area;
  - (7) shut down refrigeration system or transfer refrigerant to a receiver outside of affected area;
  - (8) investigate the use of proper safety equipment and proper procedures;
  - (9) make sure no flames or sparks enter leak area;
  - (10) provide water spray and ventilation to neutralize and reduce the concentration of ammonia;
  - (11) repair leak if possible;
  - (12) begin cleanup or neutralizing procedure; and
  - (13) notify the proper administrative authority of the problem.

Subp. 3. **Ammonia incident action plan.** An ammonia incident action plan is a mandatory document and must be available for implementation in the event of an ammonia spill or incident. The ammonia incident action plan governs the required response to an ammonia spill or leak.

### 5230.6130 DECLARATION OF TEST.

A dated declaration of test must be prepared for ammonia piping systems. The declaration must give the name of the refrigerant and the field test pressure applied to the high side and the low side of the system. The declaration of test must be signed by the licensed contractor and, if an inspector is present at the tests, the inspector must also sign the declaration. When requested, copies of the declaration must be furnished to the administrative authority.

### 5230.6200 AMMONIA HANDLING AND STORAGE.

Subpart 1. **Charging lines.** The refrigeration system must be equipped with valved charging lines to allow anhydrous ammonia to be fed into either the liquid receiver, liquid line, or low side receiver line or receiver. Charging lines must comply with the liquid line requirements of part 5230.5900.

Subp. 2. **Unloading lines.** Unloading lines must be suitable for ammonia service and designed to be capable of withstanding 350 pounds per square inch gage (24.6 kilograms/cm<sup>2</sup> gage) (2413.0 kPa gage) working pressure. Pipe must conform with the liquid line requirements of part 5230.5900 and applicable portions of parts 5230.5000 to 5230.6310.

Subp. 3. **Storage tanks.** The maximum storage tank design capacity must be 50,000 gallons (189.25 meter<sup>3</sup>) of anhydrous ammonia when held at atmospheric temperatures. Tanks must meet American Society of Mechanical Engineers Boiler and Pressure Vessel

Code, section VIII, division 1, construction and be designed for 250 pounds per square inch gage (17.57 kilograms/cm<sup>2</sup> gage) (1724.0 kPa gage) working pressure minimum.

Subp. 4. **Storage tank capacity.** A storage tank capacity for anhydrous ammonia must be limited to 56 percent of water weight capacity at 60 degrees Fahrenheit (15.6 degrees centigrade). Gage glasses must be equipped with excess flow valves to stop the flow of ammonia if breakage occurs. Meters with mercury as the manometer liquid must not be used.

Subp. 5. **Procedures.** The unloading of either tank truck or railroad tank car must be done by creating a pressure differential between the storage tank and the portable vessel or a direct transfer by suitable liquid ammonia pump. Flexible connections of ammonia design at 350 pounds per square inch gage (24.6 kilograms/cm<sup>2</sup> gage) (2413.0 kPa gage) working pressure rating must be used between the portable vessel and unloading rack. Cars must be blocked before connections are made and proper warning signs must be put in place on a railroad siding. The unloading operation must be under continuous supervision.

Subp. 6. **Masks and helmets.** Two safety masks approved under American National Standards Institute, standard Z87.1, must be located in a readily accessible location immediately adjacent to the unloading or charging operation.

## Pollution Control Agency

### Proposed Permanent Rules Relating to Nonstandard Engines; Automobile Emission Standards

#### Notice of Intent to Adopt Rules Without a Public Hearing

**NOTICE IS HEREBY GIVEN** that the Minnesota Pollution Control Agency (MPCA) intends to adopt the above-entitled rule without a public hearing following the procedures set forth in the Administrative Procedure Act for adopting rules without a public hearing in *Minnesota Statutes* § 14.22 to 14.28 (1990). The MPCA's authority to adopt the rule is set forth in *Minnesota Statutes* § 116.62 (1990).

All persons have until 4:30 p.m. May 20, 1992, to submit comments orally or in writing on the proposed rule amendments. Each comment should identify the portion of the proposed rule addressed, the reason for the comment, and any change proposed. Comment is encouraged. Written comments should be directed to Dave Kelso at the address listed below.

Mr. Dave Kelso  
Air Quality Division  
Minnesota Pollution Control Agency  
520 Lafayette Road North  
St. Paul, Minnesota 55155

Oral comments will be accepted by Mr. Kelso at the MPCA during regular business hours or over the telephone at (612) 297-5488.

The proposed amended rule may be modified if the modifications are supported by data and views submitted to the MPCA and do not result in a substantial change in the proposed rule as noticed.

The proposed amended rule, if adopted, will clarify that a Kit car is a form of a reconstructed vehicle and will identify appropriate emission standards for testing vehicles containing an exchanged engine under a variety of circumstances. The proposed amended rule is published below. One free copy of the amended rule is available upon request from Norma Florell at the address and telephone number stated below.

Any person may make a written request for a public hearing on the amended rule within the comment period. If 25 or more persons submit a written request for a public hearing within the comment period, a public hearing will be held unless a sufficient number withdraw their requests in writing. Any person requesting a public hearing should state his or her name and address and telephone number, and is encouraged to identify the portion of the proposed amended rule addressed, the reason for the request, and any change proposed.

If a public hearing is required, the MPCA will proceed pursuant to *Minnesota Statutes* § 14.131 to 14.20 (1990).

Written requests for a public hearing should be directed to Norma Florell at the address listed below.

Ms. Norma Florell  
Air Quality Division

**KEY: PROPOSED RULES SECTION** — Underlining indicates additions to existing rule language. ~~Strike outs~~ indicate deletions from existing rule language. If a proposed rule is totally new, it is designated "all new material." **ADOPTED RULES SECTION** — Underlining indicates additions to proposed rule language. ~~Strike outs~~ indicate deletions from proposed rule language.

## Proposed Rules

Minnesota Pollution Control Agency  
520 Lafayette Road North  
St. Paul, Minnesota 55155

All general questions regarding the rulemaking process should be directed to Norma Florell at (612) 296-7712.

A **STATEMENT OF NEED AND REASONABLENESS** that describes the need for and reasonableness of each provision of the proposed amended rule and identifies the data and information relied upon to support the proposed amended rule has been prepared and is available from Norma Florell upon request.

You are hereby advised, pursuant to *Minnesota Statutes* § 14.115 (1990), "Small business considerations in rulemaking," that the proposed amended rule will not have an impact on small businesses. The MPCA considered the feasibility of establishing lesser requirements for inspection of vehicles owned by small businesses but concluded that, because air pollutant emissions from vehicles owned by small businesses have an equally deleterious impact on air quality as any other vehicles, the purposes of the rules would be defeated by such a measure. The amended rule clarifies the emission standards which apply to vehicles, but does not change which vehicles are subject to testing under current rules, and is therefore not expected to increase costs of compliance for small businesses.

You are hereby advised, pursuant to *Minnesota Statutes* § 14.11, subd. 1 (1990) "Impact on Local Public Bodies," that the proposed amended rule will not have an impact on expenditure of public money by local bodies.

You are hereby advised, pursuant to *Minnesota Statutes* § 14.11, subd. 2 (1990) "Agricultural Land," that the proposed amended rule will not have an impact on agricultural land in the state.

If no hearing is required, upon adoption of the amended rule, the rule and the required supporting documents will be submitted to the Attorney General for review as to legality and form to the extent form relates to legality. Any person may request notification of the date of submission of this material to the Attorney General. Persons who wish to be advised of the submission of this material to the Attorney General, or who wish to receive a copy of the rule as adopted, must submit a written request to Norma Florell.

Charles W. Williams  
Commissioner

### Rules as Proposed

#### 7005.5030 EXHAUST EMISSION TEST.

[For text of subs 1 to 9, see M.R.]

Subp. 10. **Reconstructed (KIT) vehicles.** All reconstructed (**KIT**) subject vehicles shall be tested for compliance with the exhaust emission standards in subpart 3, Table 1 or 2, whichever is in effect, using the standards applicable to the year of manufacture of the engine installed in the vehicle.

Subp. 11. **Exchanged engines.** For the purposes of parts 7005.5010 to 7005.5105, a motor vehicle with an exchanged engine shall be classified by the model year and manufacturer's make of the exchanged engine must be tested as described in items A to C.

A. Except as provided in item B, a motor vehicle must be tested for compliance with the exhaust emission standards in subpart 3, Table 1 or 2, whichever is in effect, using the standards applicable to the model year of the vehicle's chassis.

B: A vehicle manufactured in model year 1991 or older that has received an exchanged or rebuilt engine, or other vehicle made from manufactured kit bodies (KIT cars), must be tested for compliance with the exhaust emission standards in subpart 3, Table 1 or 2, whichever is in effect, using the standards applicable to the model year of the vehicle's chassis, unless the owner of the vehicle complies with the procedure in item C.

C. If a motor vehicle described in item B has not been inspected, or if it has been inspected and failed to meet the emission standards in subpart 3, Table 1 or 2, whichever is in effect, using the standards applicable to the model year of the vehicle's chassis, the agency representative upon request by the motorist shall certify the year the engine was manufactured by checking the identification number of the engine block and by reviewing documentation provided by the vehicle owner. The vehicle must be tested for compliance with the exhaust emission standards in subpart 3, Table 1 or 2, whichever is in effect, using the year of the engine as certified by the agency representative. If the identification number on the block of the engine is absent and the vehicle owner is unable to provide documentation as to the engine year, the vehicle must be tested for compliance with the exhaust emission standards for model year 1976. If the agency representative determines that the engine was manufactured prior to 1976, the motor vehicle is not a subject vehicle.

Classification of a motor vehicle with an exchanged engine under parts 7005.5010 to 7005.5105, and receipt of a certificate of compliance or certificate of waiver for the motor vehicle shall not exempt the owner of the motor vehicle from the requirements of part 7005.1190 and *Minnesota Statutes*, section 325E.0951.

## Department of Transportation

### Proposed Permanent Rules Relating to the Port Development Assistance Program

#### Notice of Intent to Adopt Rules Without a Public Hearing

**NOTICE IS HEREBY GIVEN** that the State of Minnesota intends to adopt the above-entitled rules without a public hearing following the procedures set forth in the Administrative Procedure Act for adopting rules without a public hearing in *Minnesota Statutes*, sections 14.22 to 14.28. The statutory authority to adopt the rules is *Minnesota Statutes*, section 457A.05 (1990).

All persons have 30 days in which to submit comment in support of or in opposition to the proposed rules or any part or subpart of the rules. Comment is encouraged. Each comment should identify the portion of the proposed rules addressed, the reason for the comment, and any change proposed.

Any person may make a written request for a public hearing on the rules within the 30 day comment period. If 25 or more persons submit a written request for a public hearing within the 30 day comment period, a public hearing will be held unless a sufficient number withdraw their request in writing. Any person requesting a public hearing should state his or her name and address, and is encouraged to identify the portion of the proposed rule addressed, the reason for the request, and any change proposed. If a public hearing is required, the agency will proceed pursuant to *Minnesota Statutes*, sections 14.131 to 14.20.

Comments or written requests for a public hearing must be submitted to:

DuWayne Elliott  
Office of Railroads & Waterways  
Suite 925, Kelly Annex  
Transportation Building  
395 John Ireland Blvd.  
St. Paul, MN 55155  
612-296-0364

The proposed rules may be modified if the modifications are supported by data and views submitted to the agency and do not result in a substantial change in the proposed rule as noticed.

A copy of the proposed rules is attached to this notice.

A **STATEMENT OF NEED AND REASONABLENESS** that describes the need for and reasonableness of each provision of the proposed rule and identifies the data and information relied upon to support the proposed rules has been prepared and is available from the aforementioned person and address upon request.

If no hearing is required, upon adoption of the rules, the rules and the required supporting documents will be submitted to the Attorney General for review as to legality and form to the extent the form relates to legality. Any person may request notification of the date of submission to the Attorney General. Persons who wish to be advised of the submission of this material to the Attorney General, or who wish to receive a copy of the adopted rules, must submit the written request to aforementioned person.

Dated: 1 April 1992

James N. Denn  
Commissioner

#### Rules as Proposed (all new material)

##### 8895.0100 DEFINITIONS.

Subpart 1. **Scope.** The terms used in parts 8895.0100 to 8895.1100 have the meanings given them in this part.

Subp. 2. **Assistance agreement.** "Assistance agreement" means a formal agreement between the commissioner and an eligible applicant for port assistance improvement funds.

Subp. 3. **Commercial navigation facility.** "Commercial navigation facility" means ports or individual docks and terminals, supporting equipment, structures, and transportation facilities used by vessels transporting passengers or commodities, by vessels under construction or repair, or by commercial fishing vessels. The term does not include facilities used on a regular basis by recreational or sport fishing vessels.

**KEY: PROPOSED RULES SECTION** — Underlining indicates additions to existing rule language. ~~Strike outs~~ indicate deletions from existing rule language. If a proposed rule is totally new, it is designated "all new material." **ADOPTED RULES SECTION** — Underlining indicates additions to proposed rule language. ~~Strike outs~~ indicate deletions from proposed rule language.

## Proposed Rules

---

Subp. 4. **Commercial vessel.** "Commercial vessel" means a vessel used for transporting passengers or property, but does not include a vessel used primarily for recreation, sport, or sport fishing.

Subp. 5. **Commissioner.** "Commissioner" means the commissioner of the Minnesota Department of Transportation.

Subp. 6. **Disposal facility.** "Disposal facility" means a containment facility, a diked or undiked disposal site, or a transfer site for future beneficial reuse of dredged material.

Subp. 7. **Disposal facility costs.** "Disposal facility costs" means costs of acquisition or construction of a disposal facility.

Subp. 8. **Dock.** "Dock" means any structure on a shoreline or near shoreline development used in mooring vessels or transferring people or cargo to or from vessels.

Subp. 9. **Dredging.** "Dredging" means excavating harbor sediment or bottom materials, including mobilizing or operating equipment for excavating and transporting dredged material to a disposal facility and for placing the dredged material in the disposal facility.

Subp. 10. **Dredged material disposal.** "Dredged material disposal" means the placing of dredged material in a disposal facility.

Subp. 11. **Eligible applicant.** "Eligible applicant" means a person, company, political subdivision, or port authority that owns a commercial navigation facility.

Subp. 12. **Final engineering costs.** "Final engineering costs" means engineering costs that occur after the application for port assistance improvement funds has been completed. These costs may include, but are not limited to, the cost of final plans and specifications for the project.

Subp. 13. **Maintenance dredging.** "Maintenance dredging" means dredging an area previously dredged to a specific depth, which is not necessary for a new service.

Subp. 14. **Mn/DOT.** "Mn/DOT" means the Minnesota Department of Transportation.

Subp. 15. **Navigation system.** "Navigation system" means the commercially navigable reaches of the Mississippi, Minnesota, and St. Croix rivers; the commercial harbors on Minnesota's Lake Superior shoreline; and the commercial navigation facilities on those waterways.

Subp. 16. **Port.** "Port" means an area along one of Minnesota's navigable waterways that supports at least one terminal that takes on or discharges cargo or passengers.

Subp. 17. **Program.** "Program" means the port development assistance program established in *Minnesota Statutes*, section 457A.02.

Subp. 18. **Terminal.** "Terminal" means any structure and adjacent land area used in the actual operations or support of the transfer of commodities or passengers to or from vessels.

### 8895.0200 PROGRAM PURPOSE AND ADMINISTRATION.

Subpart 1. **Purpose.** The purpose of the port development assistance program and parts 8895.0100 to 8895.1100 is to expedite, retain, or generally improve the movement of commodities and passengers on the commercial navigation system and enhance the commercial vessel construction and repair industry in Minnesota by providing state funds in a revolving account that may be used in establishing contracts between the state and eligible applicants for port development assistance.

Subp. 2. **Commissioner to administer.** The commissioner shall administer the port development assistance program to advance the purposes of subdivision 1. In administering the program, the commissioner may:

- A. make grants and loans to eligible applicants;
- B. make assistance agreements with recipients of grants and loans; and
- C. adopt rules authorized by *Minnesota Statutes*, section 457A.05.

### 8895.0300 ELIGIBLE PROJECTS.

Subpart 1. **Description.** To be eligible for the program, a project must benefit Minnesota's shippers and receivers by improving or developing a commercial navigation facility or its components. Eligible projects include dock and terminal repair, capital improvement to a commercial navigation facility, supporting equipment directly related to loading or off-loading cargo to or from a vessel, disposal facility construction or repair, and dredging to open a new commercial navigation facility.

Subp. 2. **Location.** Eligible projects must be located on Minnesota's Lake Superior shoreline or on the shoreline of Minnesota's commercially navigable portions of the Mississippi, Minnesota, and St. Croix rivers where vessels take on or discharge commercial cargo or passengers; where commercial freight, passenger, or military vessels are built or repaired; where vehicle- or passenger-carrying ferry service operates; or where commercial fishing vessels unload fish or are headquartered.

### 8895.0400 COST ELIGIBILITY.

Subpart 1. **Eligible costs.** The types and amounts of costs eligible for state assistance must be negotiated in developing an assistance

agreement. Eligible costs include final engineering costs, capital improvements to a commercial navigation facility, construction costs and dredging costs to open a new commercial navigation facility, and other costs agreed to by the commissioner and the applicant.

Subp. 2. **Costs not eligible.** The following costs are not eligible for reimbursement under the program:

- A. an applicant's administration costs, insurance costs, and legal costs to obtain a general assistance award;
- B. the costs of acquiring permits or preparing environmental documents, feasibility studies, conceptual project designs, or design revisions;
- C. the interest on money borrowed by the applicant or interest charged to the applicant for late payment of project costs;
- D. the costs related to the routine maintenance, repair, or operation of a commercial navigation facility; and
- E. the costs of maintenance dredging to maintain an existing channel.

#### **8895.0500 PROJECT SELECTION, MINIMUM QUALIFICATIONS, AND RANKING.**

Subpart 1. **Project selection.** The commissioner shall consider the following factors in selecting projects for funding through the program:

- A. economic considerations, including determinations of:
  - (1) whether the projected additional revenue generated by the improvement project will be sufficient to recover its costs;
  - (2) the overall economic impact of the project as determined by a benefit-cost analysis;
  - (3) the potential loss of local income, taxes, or jobs if the project is not completed;
  - (4) added costs to shippers, receivers, and the local or regional economy if failure to complete the project causes significant delay or stoppage of vessel movement; and
  - (5) the added costs of full replacement of a facility over the costs of responding to an improvement need if the project is implemented; and
- B. safety considerations, including determinations of:
  - (1) improvements in vessel or cargo-handling safety at the facilities;
  - (2) improvements in working condition safety in dock cargo-handling and storage areas; and
  - (3) improvements that enhance the movement of cargo or passengers at navigation facilities.

Subp. 2. **Project funding; minimum requirements.** A project does not qualify for program funding if:

- A. the project is inconsistent with criteria in parts 8895.0100 to 8895.1100;
- B. the application is incomplete or inaccurate; or
- C. the proposed project is incompatible with applicable harbor development or local comprehensive plans.

Subp. 3. **Project ranking.** The commissioner shall establish timetables for the ranking of projects. The ranking of projects determines the priority in which funding will be considered.

Subp. 4. **Criteria for ranking projects.** The commissioner shall consider the following criteria to determine project ranking:

- A. ability of the project to expedite, retain, or generally improve the movement of passengers or cargo;
- B. ability of the project to enhance the commercial vessel construction and repair industry;
- C. ability of the project to promote identifiable economic development in and around the port and harbor;
- D. ability of the project to produce a regional or community benefit independent of an individual facility; and
- E. ability to repay a loan on the basis of the benefit-cost analysis.

Subp. 5. **Application may be resubmitted.** If the commissioner determines that an application is not eligible for ranking or is not ranked high enough for funding selection, that application may be resubmitted for the next funding cycle.

#### **8895.0600 TYPES OF ASSISTANCE PROJECTS; ELIGIBILITY; FUNDING.**

Subpart 1. **Schedule for filing applications.** The commissioner shall establish annually a deadline for filing applications for

**KEY: PROPOSED RULES SECTION** — Underlining indicates additions to existing rule language. ~~Strike outs~~ indicate deletions from existing rule language. If a proposed rule is totally new, it is designated "all new material." **ADOPTED RULES SECTION** — Underlining indicates additions to proposed rule language. ~~Strike outs~~ indicate deletions from proposed rule language.

## Proposed Rules

---

---

assistance under the program. This schedule will be published in the *State Register*. Upon request to the commissioner, schedules will be sent by mail to interested parties.

Subp. 2. **Types of assistance; eligibility.** The commissioner shall determine under items A and B the type of assistance for which a project will be eligible.

A. To be eligible to qualify for a loan, a project must satisfy one or both of the following conditions:

(1) the project expedites, retains, or generally improves the movement of commodities or passengers on the commercial navigation system; or

(2) the project enhances the commercial vessel construction and repair industry in Minnesota.

B. To qualify for a grant or a loan or a combination of both a grant and loan, the project must satisfy at least one of the conditions in item A, does not produce an increase in revenue that could be used to finance the project, and either:

(1) promotes identifiable economic development in and around ports and harbors in the state; or

(2) produces a regional or community benefit independent of an individual facility.

C. The interest rate and other terms, including security and repayments of loans, must be negotiated by the parties and must be included in the assistance agreement.

Subp. 3. **Commitment of funds.** Program funds may be committed to an eligible applicant only after a project assistance agreement is negotiated and signed by the commissioner and the applicant.

Subp. 4. **Final funding restrictions.** The commissioner shall not make final decisions on funding a proposed project in whole or in part until:

A. all legally required permits are obtained;

B. non-state-matching funds are formally committed; and

C. the project applicant is in compliance with the program agreement.

Subp. 5. **Rescinding project funding.** The commissioner shall rescind funding if the eligible applicant withdraws its application or is unable to enter into a project assistance agreement that in the commissioner's determination satisfies parts 8895.0100 to 8895.1100 and protects the state's investment.

Subp. 6. **Assigning rescinded funds.** When a project's funding is rescinded, in whole or in part, the commissioner may fund the next highest ranked, nonfunded project on the current project priority list.

Subp. 7. **Repaying loans.** A loan recipient shall repay the funds loaned by the commissioner according to the negotiated project assistance agreement. Payments must be made on a set schedule. The maximum repayment schedule must not exceed 15 years.

### 8895.0700 STATE PARTICIPATION, LIMITATIONS.

Subpart 1. **State participation, limitations.** The state's share of project costs must not exceed 50 percent of the nonfederal share of the eligible costs to be incurred by the applicant for the project.

Subp. 2. **No continuing funding responsibility.** The commissioner shall not assume a continuing funding responsibility for any commercial navigation facility project.

Subp. 3. **Fund matching.** Port improvement assistance funding must not be used as a required match with other state funds, regardless of source.

### 8895.0800 APPLICATION PROCESS.

Subpart 1. **Application submittal.** An application by an eligible applicant for program funds must be submitted to the commissioner and comply with subpart 2.

Subp. 2. **Information requirements.** An application must include, at a minimum, the following information:

A. a formal request for assistance;

B. the names of the eligible applicant's representatives who are authorized to sign forms or claims and who shall act as the applicant's contact persons for the project;

C. the name of the organization, group, or person who will accept responsibility for operating and maintaining the proposed project after completion;

D. documentation that the proposed project is consistent with the harbor development plan or with the comprehensive plan of the local government if plans have been adopted, along with a copy of those plans attached to the application;

E. documentation of the source of the required matching funds in the amount specified in the assistance agreement;



F. a financial statement, including a credit history;

G. a description of the project that, at a minimum, must include:

- (1) a detailed description of the work to be performed including schematic plans, drawings, and sounding reports;
- (2) a description of the means by which the work is to be performed;
- (3) a statement of justification and reasons for undertaking the project;
- (4) a map, sketch, or other depiction of the project site and its surrounding area including all transportation access facilities;
- (5) a statement of current ownership of the project site and facilities and of the ownership proposed upon completion of the project;
- (6) a proposed time schedule for performing major project tasks; and
- (7) an operating plan as required, when requested by the commissioner; and

H. a full discussion of anticipated economic impacts, including:

(1) a detailed estimate of project costs, indicating the eligible applicant's cost share, amount of state funding requested, other sources or potential sources of funds, and a full description of timetables and conditions affecting funds other than funds already budgeted by the applicant;

(2) an estimate of project development costs, which may include, but is not limited to, the value of existing land and facilities, the cost of additional site development, and the cost of storage or transfer facilities;

(3) an estimate of the applicant's annual revenues from the project if completed, or of revenues lost if the project is not completed, and an estimate of the annual costs necessary to maintain the project property;

(4) an estimate of the dollar value to the local economy directly attributable to the proposed project, or of lost dollar value to the local economy if the project is not completed, including a detailed description of the assumptions and the bases for those assumptions;

(5) a list of commodities and a disclosure of the tonnage of waterborne commerce using the project property and expected to use the project property if the project is completed;

(6) a list of permits necessary for the project to proceed and, if the permits have not been obtained, a description of the actions taken or to be taken to obtain the permits;

(7) copies of required environmental documents; and

(8) how the applicant plans to repay a loan.

#### **8895.0900 ASSISTANCE AGREEMENT, FORMAL IMPLEMENTATION.**

Port development assistance projects must be formally implemented through assistance agreements between the commissioner and the eligible applicant. If the eligible applicant is unable or unwilling to enter into an assistance agreement with the commissioner in the calendar year for which the applicant's project is approved, the applicant may submit another application for the project before the commissioner will again consider it for funding in a subsequent funding period.

#### **8895.1000 ASSISTANCE AGREEMENT, REQUIRED PROVISIONS.**

Subpart 1. **Maximum funds.** The maximum amount of assistance funds agreed to by the commissioner must be stated in the assistance agreement for the project.

Subp. 2. **Liability; insurance.** The assistance agreement must require an assistance recipient to save and hold the commissioner and Mn/DOT harmless from and against all liability, damage, loss, claims, demands, and actions of any nature that may be related to the project. The assistance recipient shall provide, at its own expense, a comprehensive general liability insurance policy, with per-occurrence limits to be determined by the commissioner.

Subp. 3. **Bonds.** The assistance agreement must require an assistance recipient to provide evidence of performance and payment bonds for the full amount of construction contracts let by the applicant in connection with the project.

Subp. 4. **Records; audit.** The assistance agreement must require an assistance recipient to maintain project-related books and records according to Mn/DOT specifications contained in the agreement and make the records available to the commissioner for audit

**KEY: PROPOSED RULES SECTION** — Underlining indicates additions to existing rule language. ~~Strike outs~~ indicate deletions from existing rule language. If a proposed rule is totally new, it is designated "all new material." **ADOPTED RULES SECTION** — Underlining indicates additions to proposed rule language. ~~Strike outs~~ indicate deletions from proposed rule language.

## Proposed Rules

purposes. In addition, assistance recipients shall make periodic progress reports to the commissioner. The content and timing of these reports must be as specified in the grant or loan agreement.

Subp. 5. **Inspection.** The assistance agreement must require an assistance recipient to permit the commissioner to inspect projects or request applicants to provide independent inspection at any time.

Subp. 6. **Criteria for repaying funds.** The commissioner shall notify a recipient of program grants or loans that the recipient is required to repay, if:

A. the project for which the assistance funds are awarded is not completed in accordance with all terms of the assistance agreement, including required completion dates; or

B. a commercial navigation facility for which funds were awarded is converted during the time established in the agreement to a use inconsistent with the purposes of the program or inconsistent with the terms of the agreement or is converted during that period to a use not approved in writing by the commissioner.

### 8895.1100 VARIANCE FROM AGREEMENT PROVISIONS.

The commissioner shall grant variances for some of the criteria of this chapter in certain cases if the majority of the criteria of this chapter are satisfied and a showing is made that demonstrable hardship to the community or the region would develop without completion of the project.

## Adopted Rules

The adoption of a rule becomes effective after the requirements of Minn. Stat. §14.14-14.28 have been met and five working days after the rule is published in *State Register*, unless a later date is required by statutes or specified in the rule.

If an adopted rule is identical to its proposed form as previously published, a notice of adoption and a citation to its previous *State Register* publication will be printed.

If an adopted rule differs from its proposed form, language which has been deleted will be printed with strikeouts and new language will be underlined. The rule's previous *State Register* publication will be cited.

An emergency rule becomes effective five working days after the approval of the Attorney General as specified in Minn. Stat. §14.33 and upon the approval of the Revisor of Statutes as specified in §14.36. Notice of approval by the Attorney General will be published as soon as practicable, and the adopted emergency rule will be published in the manner provided for adopted rules under §14.18.

## Board of Dentistry

### Adopted Permanent Rules Relating to Licensure

The rules proposed and published at *State Register*, Volume 16, Number 19, pages 1118-1123, November 4, 1991 (16 SR 1118), are adopted with the following modifications:

#### Rules as Adopted

#### 3100.1200 APPLICATION FOR LICENSE TO PRACTICE DENTAL HYGIENE.

~~Subpart 1. Form and credentials.~~ A person desiring licensure to practice dental hygiene must present an application and credentials as prescribed by the act and shall conform to the following rules of the board:

~~G. An applicant who wants the authority under the license to administer nitrous oxide inhalation analgesia must comply with part 3100.3600, subparts 4 and 5.~~

~~Subp. 2. Nitrous oxide inhalation analgesia.~~ A person applying for a license to practice dental hygiene or a dental hygienist already licensed who wants the authority under the license to administer nitrous oxide inhalation analgesia must comply with the applicable requirements of part 3100.3600, subparts 4 and 5.

#### 3100.3600 TRAINING AND EDUCATIONAL REQUIREMENTS TO ADMINISTER ANESTHESIA AND SEDATION.

Subpart 1. **Prohibitions.** Dental hygienists and dental assistants may not administer general anesthesia or, conscious sedation, or nitrous oxide inhalation analgesia. ~~Dental assistants may not administer nitrous oxide inhalation analgesia.~~

Subp. 2. **General anesthesia.** A dentist may administer a pharmacological agent for the purpose of general anesthesia only pursuant to items A to C.

A. Beginning January 1, 1993, a dentist may administer a pharmacological agent for the purpose of general anesthesia only after satisfactorily completing the requirements in clause (1) or (2) in addition to the requirements in clause (3).

(1) a didactic and clinical program at a dental school, hospital, or graduate medical or dental program accredited by the Commission on Accreditation, resulting in the dentist becoming clinically competent in the administration of general anesthesia. The program must be equivalent to a program for advanced specialty education in oral ~~surgery~~ and maxillofacial surgery; or

(3) an advanced cardiac life support course and must be currently certified in advanced cardiac life support or basic cardiac life support as provided in educational programs recognized by the American Heart Association, the American Red Cross, or other agencies whose courses are equivalent to the American Heart Association or American Red Cross courses.

C. A dentist shall administer a pharmacological agent for the purpose of general anesthesia only by application of the appropriate systems and drugs for the delivery of general anesthesia ~~and recovery of a patient sufficient to permit safe discharge from the facility.~~ Prior to discharging the patient, the dentist shall ensure that the effects of the medication have sufficiently dissipated to a level where in-office monitoring is no longer required.

Subp. 3. **Conscious sedation.** A dentist may administer a pharmacological agent for the purpose of conscious sedation only pursuant to items A to C.

A. Beginning January 1, 1993, a dentist may administer a pharmacological agent for the purpose of conscious sedation of a patient only after satisfactorily completing:

(2) an advanced cardiac life support course and must be currently certified in advanced cardiac life support or basic cardiac life support as provided in educational programs recognized by the American Heart Association, the American Red Cross, or other agencies whose courses are equivalent to the American Heart Association or American Red Cross courses.

B. A dentist shall be prepared and competent to diagnose, resolve, and reasonably prevent any untoward reaction ~~of or~~ medical emergencies that may develop any time after rendering a patient in the state of conscious sedation. A dentist shall apply the current standard of care to monitor and evaluate a patient's blood pressure, pulse, respiratory function, and cardiac activity. The current standard of care to assess respiratory function shall require the monitoring of tissue oxygenation or the use of a superior method of monitoring respiratory function.

C. A dentist shall administer a pharmacological agent for the purpose of conscious sedation only by application of the appropriate systems and drugs for the delivery of conscious sedation ~~and recovery of a patient sufficient to permit safe discharge from the facility.~~ Prior to discharging the patient, the dentist shall ensure that the effects of the medication have sufficiently dissipated to a level where in-office monitoring is no longer required.

Subp. 4. **Nitrous oxide inhalation analgesia.** A ~~licensee~~ dentist may administer nitrous oxide inhalation analgesia only pursuant to items A to ~~E~~ D and subpart 5.

A. Prior to January 1, 1993, a licensed dentist who is currently administering nitrous oxide inhalation analgesia may register that fact with the board pursuant to subpart 5, item A. Such registered dentists may continue to administer nitrous oxide inhalation analgesia and need not comply with item B.

~~B.~~ Beginning January 1, 1993, a dentist who has not previously registered with the board pursuant to subpart 5, item A, ~~and a dental hygienist~~ may administer nitrous oxide inhalation analgesia only after satisfactorily completing a dental school, ~~or~~ postdental graduate, ~~dental hygiene, or postdental hygiene~~ education course on the administration of nitrous oxide inhalation analgesia from an institution accredited by the Commission on Accreditation. The course must include a minimum of 16 hours of didactic instruction and supervised clinical experience using fail-safe anesthesia equipment capable of positive pressure respiration.

~~B- C.~~ A ~~licensee~~ dentist must ~~have successfully completed and~~ be currently certified in advanced cardiac life support or basic cardiac life support as provided in educational programs recognized by the American Heart Association, the American Red Cross, or other agencies whose courses are equivalent to the American Heart Association or American Red Cross courses.

~~C- D.~~ A ~~licensee~~ dentist may only use fail-safe anesthesia equipment capable of positive pressure respiration.

Subp. 5. **Notice to board.** A dentist who administers a pharmacological agent for the purpose of general anesthesia ~~or,~~ conscious sedation, or a ~~licensee~~ who administers nitrous oxide inhalation analgesia shall submit to the board the information in items A to C.

B. Beginning January 1, 1993, a dentist may administer pharmacological agents for the purpose of general anesthesia or conscious sedation only if the dentist has submitted the following information to the board on forms provided by it: the name, address,

**KEY: PROPOSED RULES SECTION** — Underlining indicates additions to existing rule language. ~~Strike outs~~ indicate deletions from existing rule language. If a proposed rule is totally new, it is designated "all new material." **ADOPTED RULES SECTION** — Underlining indicates additions to proposed rule language. ~~Strike outs~~ indicate deletions from proposed rule language.

## Adopted Rules

and telephone number of the institution at which the dentist took the program or residency that complies with subparts 2, item A, subitem (1) or (2); and 3, item A, subitem (1), a certified copy of the dentist's transcript or other official record from the institution verifying that the dentist satisfactorily completed the program, residency, or course; the name, address, and telephone number of the institution or other agency at which the dentist successfully completed the advanced cardiac life support course required by subparts 2, item A, subitem (3); and 3, item A, subitem (2); and a statement that the dentist is currently certified in advanced cardiac life support or basic cardiac life support required by subparts 2, item A, subitem (3); and 3, item A, subitem (2). After this initial submission, dentists shall submit a statement of current certification in advanced cardiac life support or basic cardiac life support every year on their license renewal application or other form provided by the board.

C. Beginning January 1, 1993, a licensee dentist not previously registered with the board pursuant to subpart 5, item A, may administer nitrous oxide inhalation analgesia only after the licensee dentist has submitted the following information to the board on forms provided by it: the name, address, and telephone number of the institution at which the licensee dentist took the course that complies with subpart 4, item A B; a certified copy of the licensee's dentist's transcript or other official record from the institution verifying that the licensee dentist satisfactorily completed the course; and a statement that the licensee dentist is currently certified in advanced cardiac life support or basic cardiac life support required by subpart 4, item B C. After this initial submission, a licensee dentist shall submit a statement of current certification in advanced cardiac life support or basic cardiac life support every year on the license renewal application or other form provided by the board.

### 3100.6200 CONDUCT UNBECOMING A LICENSEE OR REGISTRANT.

"Conduct unbecoming a person licensed to practice dentistry or dental hygiene or registered as a dental assistant or conduct contrary to the best interests of the public," as used in *Minnesota Statutes*, section 150A.08, subdivision 1, clause (6), shall include the act of a dentist, dental hygienist, registered dental assistant, or applicant in:

K. failing to maintain adequate safety and sanitary conditions for a dental office as specified in part 3100.6300; and

L. failing to provide access to and transfer of medical and dental records as prescribed by *Minnesota Statutes*, section 144.335; and

~~M. in the case of a dentist, ordering, directing, or otherwise influencing an auxiliary to perform a patient care duty for which the auxiliary is not adequately trained, licensed, or registered or for which the auxiliary is not provided adequate facilities, equipment, instruments, assistance, or time.~~

### 3100.6300 ADEQUATE SAFETY AND SANITARY CONDITIONS FOR DENTAL OFFICES.

Subp. 11. **Infection control.** Dental health care workers shall comply with the most current infection control recommendations, guidelines, precautions, procedures, practices, strategies, and techniques specified in the United States Department of Health and Human Services, Public Health Service, Centers for Disease Control ~~publication entitled~~ publications of the Morbidity and Mortality Weekly Report (MMWR). The current infection control techniques set forth in the MMWR dated July 12, 1991, volume 40, number RR-8, pages 1 to 9, are hereby incorporated by reference. This document is incorporated by reference and The MMWR is available at the Minnesota State Law Library or, by interlibrary loan, or by subscription from the United States Department of Health and Human Services, Public Health Service, Centers for Disease Control. The infection control standards stated in the MMWR are not subject to frequent change.

Subp. 13. **CPR training.** A minimum of one person who is currently certified in advanced cardiac life support or basic cardiac life support as provided in educational programs recognized by the American Heart Association, the American Red Cross, or other agencies whose courses are equivalent to the American Heart Association or American Red Cross courses must be present in the dental office when dental services are provided.

### 3100.8500 REGISTERED DENTAL ASSISTANTS.

Subpart 1. **Duties under indirect supervision.** A registered dental assistant, in addition to the services performed by the assistant, may perform the following services if the dentist is in the office, authorizes the procedures, and remains in the office while the procedures are being performed:

B. take ~~irreversible hydrocolloid~~ impressions for study casts and ~~opposing casts and~~ appropriate bite registration for study, ~~opposing casts, and orthodontic working casts.~~ Dental assistants shall not take impressions and bite registrations for final construction of fixed and removable prostheses;

J. monitor a patient who has been induced by a dentist into nitrous oxide inhalation analgesia; ~~and~~

K. place and remove elastic orthodontic separators; and

L. remove and replace ligature ties on orthodontic appliances.

Subp. 1a. **Duties under direct supervision.** A registered dental assistant may perform the following services if the dentist is in the dental office, personally diagnoses the condition to be treated, personally authorizes the procedure, and evaluates the performance of the auxiliary before dismissing the patient:

B. ~~remove and replace ligature ties on orthodontic appliances;~~

~~C.~~ etch appropriate enamel surfaces before bonding of orthodontic appliances by a dentist;

~~D.~~ C. etch appropriate enamel surfaces and apply pit and fissure sealants. Before the application of pit and fissure sealants, a registered dental assistant must have successfully completed a course in pit and fissure sealants at a dental school, dental hygiene school, or dental assisting school that has been accredited by the Commission on Accreditation and includes a minimum of eight hours didactic instruction and supervised preclinical or clinical experience; and

~~E.~~ D. make preliminary adaptation of temporary crowns.

#### **3100.8700 DENTAL HYGIENISTS.**

Subpart 1. **Duties under general supervision.** A dental hygienist may perform the following services if the dentist has authorized them and the hygienist carries them out in accordance with the dentist's diagnosis and treatment plan:

D. dietary analysis, salivary analysis, and preparation of smears for dental health purposes; ~~and~~

E. application of pit and fissure sealants; and

F. remove excess bond material from orthodontic appliances.

Subp. 2. **Duties under indirect supervision.** A dental hygienist may ~~perform the following procedures~~ remove marginal overhangs if the dentist is in the office, authorizes the procedures, and remains in the office while the procedures are being performed; ~~and~~

~~A. remove marginal overhangs; and~~

~~B. induce into nitrous oxide inhalation analgesia a patient who has been prescribed its use by a dentist, only for the purpose of alleviating pain for dental hygiene procedures and provided the hygienist has met the educational requirements in part 3100.3600, subpart 4, and has provided notice to the board pursuant to part 3100.3600, subpart 5, item C.~~

Subp. 2a. **Duties under direct supervision.** A dental hygienist may perform the following procedures if the dentist is in the office, personally diagnoses the condition to be treated, personally authorizes the procedure, and evaluates the performance of the dental hygienist before dismissing the patient:

~~A. remove bond material from orthodontic appliances;~~

~~B. remove and replace ligature ties on the orthodontic appliances;~~

~~C.~~ etch appropriate enamel surfaces before bonding of orthodontic appliances by a dentist; and

~~D.~~ B. make preliminary adaptation of temporary crowns.

## **Department of Health**

### **Adopted Permanent Rules Relating to Eligible Analytes under the Clean Water and Safe Drinking Water Program**

The rules proposed and published at *State Register*, Volume 16, Number 17, pages 1026-1030, October 21, 1991 (16 SR 1026), and Volume 16, Number 19, page 1124, November 4, 1991 (16 SR 1124), are adopted with the following modifications:

#### **Rules as Adopted**

#### **4740.2040 CERTIFIED TEST CATEGORIES.**

Subp. 5. **Volatile organic compounds (VOCs)**

A. Analytes eligible for certification under the Clean Water Program are:

(6) ~~D~~ichlorofluoromethane;

(7) Trichlorofluoromethane;

(8) ~~T~~richlorotrifluoroethane;

(9) (7) 1,1-Dichloroethene;

**KEY: PROPOSED RULES SECTION** — Underlining indicates additions to existing rule language. ~~Strike outs~~ indicate deletions from existing rule language. If a proposed rule is totally new, it is designated "all new material." **ADOPTED RULES SECTION** — Underlining indicates additions to proposed rule language. ~~Strike outs~~ indicate deletions from proposed rule language.

## Adopted Rules

---

- (10) ~~Allyl Chloride~~;
- (11) ~~(8) Methylene chloride~~;
- (12) ~~(9) trans-1,2-Dichloroethene~~;
- (13) ~~(10) 1,1-Dichloroethane~~;
- (14) ~~(11) 2,2-Dichloropropane~~;
- (15) ~~(12) cis-1,2 Dichloroethene~~;
- (16) ~~(13) Chloroform~~;
- (17) ~~(14) Bromochloromethane~~;
- (18) ~~(15) 1,1,1-Trichloroethane~~;
- (19) ~~1,1-Dichloropropene~~;
- (20) ~~(16) Carbon tetrachloride~~;
- (21) ~~(17) 1,2-Dichloroethane~~;
- (22) ~~(18) Trichloroethene~~;
- (23) ~~(19) 1,2-Dichloropropane~~;
- (24) ~~(20) Bromodichloromethane~~;
- (25) ~~(21) Dibromomethane~~;
- (26) ~~(22) cis-1,3-Dichloropropene~~;
- (27) ~~(23) trans-1,3-Dichloropropene~~;
- (28) ~~(24) 1,1,2-Trichloroethane~~;
- (29) ~~(25) 1,3-Dichloropropane~~;
- (30) ~~(26) Tetrachloroethene~~;
- (31) ~~(27) Chlorodibromomethane~~;
- (32) ~~(28) 1,2-Dibromoethane~~;
- (33) ~~(29) Chlorobenzene~~;
- (34) ~~(30) 1,1,1,2-Tetrachloroethane~~;
- (35) ~~(31) Bromoform~~;
- (36) ~~(32) 1,1,2,2-Tetrachloroethane~~;
- (37) ~~(33) 1,2,3-Trichloropropane~~;
- (38) ~~(34) Bromobenzene~~;
- (39) ~~(35) 2-Chlorotoluene~~;
- (40) ~~(36) 4-Chlorotoluene~~;
- (41) ~~(37) 1,3-Dichlorobenzene~~;
- (42) ~~(38) 1,4-Dichlorobenzene~~;
- (43) ~~(39) 1,2-Dichlorobenzene~~;
- (44) ~~(40) 1,2-Dibromo-3-Chloropropane~~;
- (45) ~~(41) 1,2,4-Trichlorobenzene~~;
- (46) ~~(42) Hexachlorobutadiene~~;
- (47) ~~(43) 1,2,3-Trichlorobenzene~~;
- (48) ~~Ethyl Ether~~;
- (49) ~~Acetone~~;
- (50) ~~Methyl tertiary Butyl Ether~~;
- (51) ~~Methyl Ethyl Ketone~~;
- (52) ~~Tetrahydrofuran~~;

- (53) (44) Benzene;
- (54) ~~Methyl Isobutyl~~ Ketone;
- (55) (45) Toluene;
- (56) (46) Ethylbenzene;
- (57) (47) m + p-Xylene;
- (58) (48) o-Xylene;
- (59) (49) Styrene;
- (60) (50) Isopropylbenzene;
- (61) (51) n-Propyl Benzene;
- (62) (52) 1,3,5-Trimethylbenzene;
- (63) (53) Tert-Butylbenzene;
- (64) (54) 1,2,4-Trimethylbenzene;
- (65) (55) sec-Butylbenzene;
- (66) (56) p-Isopropyltoluene;
- (67) (57) n-Butylbenzene; and
- (68) (58) Naphthalene.

## Department of Jobs and Training

### Adopted Permanent Rules Governing Designation and Recognition of Community Action Agencies and Granting of Funds for Community Action Programs

The rules proposed and published at *State Register*, Volume 15, Number 36, pages 1902-1914, March 4, 1991 (15 SR 1902), and Volume 16, Number 24, pages 1429-1430, December 9, 1991 (16 SR 1429), are adopted with the following modifications:

#### Rules as Adopted

##### 3350.0020 DEFINITIONS.

Subp. 3. **Applicant.** "Applicant" means a community action agency, including an Indian reservation government or the ~~Minnesota Migrant Council~~ Midwest Farmworker Employment and Training, Inc., which applies annually for a grant under the act from the department to fund a community action program.

Subp. 16. **Grantee.** "Grantee" means any CAA, including an Indian reservation government or the ~~Minnesota Migrant Council~~ Midwest Farmworker Employment and Training, Inc., whose application to receive Minnesota economic opportunity grant money or CSBG money or both has been approved by the department.

##### 3350.0030 DESIGNATION OF COMMUNITY ACTION AGENCIES.

Subp. 9. **Review by department.** Before provisional recognition ~~can~~ may occur in part 3350.0040, subpart 1, the governing body must have submitted to the department for review copies of the following documents:

- A. eligibility documents required in ~~part 3350.0030~~, subpart 2;

##### 3350.0040 RECOGNITION OF COMMUNITY ACTION AGENCIES.

Subpart 1. **Provisional recognition.** The department will provisionally recognize a designation if the department establishes compliance with applicable state law, federal law, all the designation requirements of part 3350.0030, and, where applicable, with the change of designation requirements of part 3350.0050. Provisional recognition ~~can~~ may occur within 60 calendar days of the department's receipt of the documents required in part 3350.0030, subpart ~~8~~ 9, an approved transition plan, where applicable, as specified in part 3350.0050, subpart 4, and the most current copies of the following:

**KEY: PROPOSED RULES SECTION** — Underlining indicates additions to existing rule language. ~~Strike outs~~ indicate deletions from existing rule language. If a proposed rule is totally new, it is designated "all new material." **ADOPTED RULES SECTION** — Underlining indicates additions to proposed rule language. ~~Strike outs~~ indicate deletions from proposed rule language.

## Adopted Rules

Subp. 2. **Governor's recognition.** After the applicable requirements in subpart 1 have been met and the department has provisionally recognized a designation and ~~where applicable requirements in subpart 1 have been met~~, the department will request recognition by the governor.

Subp. 3. **Maintenance of recognition.** To maintain recognition, a CAA must by ~~June 30 of each year~~ annually ensure that the department has the most current copies of the following:

Subp. 4. **Failure to maintain recognition.** The department may proceed to withhold available funds under part 3350.0100, subpart 1, item D, where a CAA fails to maintain its recognition under this part. If, following periods of both withholding and funding termination under part 3350.0100, subpart 2, the CAA has still not successfully complied with all of the requirements in subpart 3, the department will terminate the CAA's recognition and all future funding under part 3350.0060, subpart 3 1, item C or F.

### 3350.0050 CESSATION AND CHANGE OF DESIGNATION.

Subp. 3. **Procedure.** The governing body must follow the procedure provided in part 3350.0030 in order to change designation and must also prepare a transition plan for continuation of community action program services. The governing body must submit the transition plan to the department simultaneously with the notice of intent to designate. In addition to the notice requirements in part 3350.0030, subpart 3, the governing body must also serve copies of the notice of intent to designate and the notice of public hearing upon any existing CAA concurrently operating in the same political subdivision and all subgrantees ~~directly affected by cessation and change of designation~~, in the service area. Upon request, copies of the designee's eligibility documents and the transition plan must be made available by the governing body to any interested party.

Subp. 4. **Additional review by the department.** In addition to the review requirements in part 3350.0030, subpart 8 9, the department must also review the transition plan for service delivery in the interim before the governor's recognition as provided in part 3350.0040, subpart 2. The department has 30 calendar days from the date of receipt of the transition plan to either approve or disapprove of the plan. If the transition plan is not approved, the governing body may not proceed to designate a CAA under the procedure of part 3350.0030. Without an approved transition plan in operation, the department will not forward to the governor a request for recognition as provided in part 3350.0040. If the transition plan is not approved, the governing body may submit a subsequent transition plan consistent with the department's comments. Along with the transition plan the department must also receive evidence of service of additional notice on interested parties as required in subpart 3.

### 3350.0110 PROGRAM GUIDELINES AND ELIGIBLE ACTIVITIES.

Subp. 3. **Federal prohibitions.** Activities ineligible for funding with CSBG money are those listed in the annual CSBG state plan. A copy of the annual CSBG state plan is available by request from the ~~Economic Opportunity Office~~, Department of Jobs and Training, ~~670~~ 690 American Center Building, 150 East Kellogg Boulevard, Saint Paul, Minnesota 55101.

### 3350.0160 ADMINISTRATION OF GRANTS.

Subpart 1. **Grantee financial control system.** Grantees must establish and use a financial control system which complies with federal and state reporting and fiscal procedures. The federal and state requirements are contained in Department of Jobs and Training Subgrantee Administrative Requirements No. 1, as revised or superseded. This ~~publication document~~ is incorporated by reference, and is not subject to frequent change. It is available from the State Law Library.

Subp. 3. **Alterations.** A grantee must obtain prior written approval from the ~~Economic Opportunity Office~~ department before changing its work plan and budget as described in its approved application.

### 3350.0170 GRANT APPLICATIONS.

Subpart 1. **Forms and documents.** All forms necessary for completion of the application will accompany the annual guidelines mailed to all grantees. Assistance in completing the forms may be requested directly from the ~~Economic Opportunity Office~~ department at its central office. Each CAA will submit to the department an annual work plan and budget on forms supplied by the department as part of the grant application process. Each work plan for the subsequent year will include a narrative comprised of the following:

Subp. 2. **Grant application deadlines.** Applications for a program year must be received by the ~~Economic Opportunity Office~~ department no later than June 30 immediately preceding the program year.

Subp. 3. **Waiver of application deadline.** Upon written request, the ~~Economic Opportunity Office~~ department may waive the application deadline provided in subpart 2 and allow an applicant to submit its grant application after that date. A request for a waiver must be signed by the chair of the applicant's board of directors and contain justification of the local need for a waiver. The request for a waiver must be received by the ~~Economic Opportunity Office~~ department on or before June 30. The ~~Economic Opportunity Office~~ department will respond to the request in writing. If the ~~Economic Opportunity Office~~ department is persuaded by the local need, it will grant a waiver and establish another deadline for receipt of the application. Local need is demonstrated if a CAA, through no fault of its own, cannot meet the application deadline because of the following:

Subp. 6. **Denial of application.** Before the department denies an application, it will, as soon as possible, provide written notification of the deficiency leading to a possible denial and, where appropriate, request a revision of the application, supplementary information



or other required documents. An application will be denied if any of the following occur:

C. applicant submits a noncomplying application where:

(2) applicant cannot demonstrate adequate fiscal management capabilities as required in part ~~3350.0170~~ 3350.0160; or

D. applicant, after a period of funding termination, has not remedied a long-term defect that first led to withholding under part 3350.0100, subpart 2. The department's denial of an application based on items A, B, and C is cause for termination of available funds for an entire program year under part 3350.0060, subpart 1, item F. Depending on the circumstances, the department's denial of an application based on item D is cause for termination of available funds for an entire program year under part 3350.0060, subpart 1, item F, or all future funding under part 3350.0040, subpart 4.

## Pollution Control Agency

### Adopted Permanent Rules Relating to Hazardous Waste

The rules proposed and published at *State Register*, Volume 16, Number 23, pages 1394-1399, December 2, 1991 (16 SR 1394), are adopted as proposed.

## Pollution Control Agency

### Adopted Permanent Rules Relating to Ash Management

The rules proposed and published at *State Register*, Volume 15, Number 52, pages 2704-2730, June 24, 1991 (15 SR 2704), are adopted with the following modifications:

#### Rules as Adopted

#### **7001.3480 FINAL APPLICATION INFORMATION REQUIREMENTS FOR MUNICIPAL SOLID WASTE COMBUSTOR ASH LAND DISPOSAL FACILITIES.**

The application for a municipal solid waste combustor ash land disposal facility permit must include the information in items A to I in addition to the information required by part 7001.3300.

C. A description of how the requirements of part 7035.2885, subparts 4 and 5, regarding maximum leachable contaminant levels will be met. If the design of the land disposal facility liner does not meet the minimum specifications of part 7035.2885, subpart 11, item P, the application must include a contingency action plan describing steps which the owner or operator will take if the results of ash testing or actual leachate analysis exceed the limits allowed based on the design of the facility. All applications must include an assessment of the results of ash testing and actual leachate analysis representative of the ash to be accepted at the facility. This assessment must include the following items:

(1) calculations of "results," as defined in part 7035.2885, subpart 4, item A;

(2) assessment of trends over time in the results of ash testing and actual leachate analysis; and

(3) descriptions of any anticipated changes in the design of, or waste combusted at, the waste combustor or combustors which generate ash to be accepted at the land disposal facility, and predictions of how those changes will affect the chemical and physical characteristics of the ash disposed of at the facility.

#### **7035.0300 DEFINITIONS.**

Subp. 35. **Energy recovery facility.** "Energy recovery facility" means a facility used to capture the heat value of solid waste for conversion to steam, electricity, or immediate heat by direct combustion or by first converting it into an intermediate fuel product. Energy recovery facilities include, but are not limited to, Municipal solid waste combustors are included in the definition of energy recovery facilities.

Subp. 45. **Industrial solid waste.** "Industrial solid waste" means all solid waste generated from an industrial or manufacturing process and solid waste generated from nonmanufacturing activities such as service and commercial establishments. Industrial solid waste does not include office materials, restaurant and food preparation waste, discarded machinery, demolition debris, municipal solid waste combustor ash, or household refuse.

**KEY: PROPOSED RULES SECTION** — Underlining indicates additions to existing rule language. ~~Strike outs~~ indicate deletions from existing rule language. If a proposed rule is totally new, it is designated "all new material." **ADOPTED RULES SECTION** — Underlining indicates additions to proposed rule language. ~~Strike outs~~ indicate deletions from proposed rule language.

## Adopted Rules

### 7035.0700 STORAGE OF SOLID WASTE AT INDIVIDUAL PROPERTIES.

Subp. 6. **Municipal solid waste combustor ash.** Municipal solid waste combustor ash must be stored in a manner which minimizes the emission of fugitive dust and escape of liquid which has been in contact with ash. Liquid that drains from the ash must be collected and reused at the facility, unless the commissioner finds that reuse of the liquid is not feasible based on the design of the facility, in which case the commissioner may approve another management method. Floor or surface drains serving ash collection, storage, and handling areas must not be connected to uncontaminated storm water run-off drains. Except for ash samples collected and stored according to part 7035.2910, a municipal solid waste combustor may not store ash for more than ~~15~~ five calendar days after the date the ash was generated. The maximum amount of ash stored at the facility must not exceed ~~15~~ five days of daily production. The commissioner shall approve storage of a larger quantity of ash or storage for a longer period of time if the waste is kept in a contained area meeting the requirements of a solid waste storage facility under part 7035.2885.

### 7035.2555 LOCATION STANDARDS.

Subp. 2. **Other location standards.** An owner or operator may not establish or construct a solid waste management facility in the following areas:

- A. within a shoreland or wild and scenic river land use district governed by chapters 6105 and 6120;

### 7035.2885 MUNICIPAL SOLID WASTE COMBUSTOR ASH LAND DISPOSAL FACILITIES.

Subp. 2. **Exemptions.** Upon application to and approval by the commissioner, the owner and operator of a land disposal facility which disposes of waste combustor ash which meets the requirements of items A and B are exempt from the requirements of this part. The owner or operator must maintain evidence of compliance with this part in the operating record required by part 7035.2575 None.

A. The design of the land disposal facility at a minimum must comply with the requirements of part 7035.2815, subparts 6, item D, and 7, including consideration of whether leachate from the municipal solid waste combustor ash will be compatible with the liner system.

B. Results of ash testing must meet the requirements of subitems (1) to (3). Results must be calculated according to subitem (4). If the ash is a mixture of fly and bottom ash, then the fly ash tested alone must meet the requirements of this item.

(1) Results of total composition testing for dioxins and furans performed according to part 7035.2910, subpart 4, item A, subitem (3), expressed as total 2,3,7,8-TCDD equivalence, must be lower than one mg/kg.

(2) Results of testing ash using EPA method 1312 must be lower than one-half the maximum leachable contaminant levels given in subpart 5.

(3) If ash will be codisposed with acidic wastes or wastes that may produce acids as a result of decomposition, results of testing ash leaching potential using EPA method 1311 in accordance with part 7035.2910, subpart 12, item A, must be lower than twice the maximum leachable contaminant levels given in subpart 5.

(4) For the purpose of subitems (1) to (3), "results" means the upper 80 percent confidence limit of a rolling data set calculated according to units (a) to (e).

(a) The rolling data set must consist of results of the specified test for the preceding 12 months, or the time period since a change was made in waste combusted, waste combustor operations, or ash processing which significantly alters ash quality, whichever time period is shorter.

(b) If data from only one quarter are used to calculate results, the owner or operator must calculate the upper 80 percent confidence limit for the data using equations for random sampling shown in Table 9-1 of EPA SW-846. Part 7035.0605 incorporates this document by reference and establishes its availability.

(c) If data from two or more quarters are used to calculate results, the owner or operator must calculate the upper 80 percent confidence limit for the data using equations for stratified random sampling shown in Table 9-1 of EPA SW-846, using each quarter as a stratum. The fraction of the population represented by each stratum ( $W^h$ ) must be selected based on the number of quarters of data to be used and the relative amounts of ash produced during each quarter.

Subp. 3. **Acceptable wastes.** Only municipal solid waste combustor ash and other wastes, excluding municipal solid waste, approved by the commissioner according to the procedures in this subpart may be disposed of in a waste combustor ash land disposal facility.

The owner or operator must submit requests for approval to codispose of other wastes to the commissioner in writing. Requests must state the physical and chemical characteristics of the waste, including results of EPA Method 1311 leach test, EPA Method 1312 leach test, and total composition analysis. The waste must be analyzed for total composition for the parameters in part 7035.2910, subpart 4, item A, tables (1) and (2). Leach test samples must be analyzed for all parameters detected by total composition analysis. The request must also include an assessment of the potential for the waste to affect the leaching potential of waste combustor ash and other wastes previously approved for codisposal. The commissioner shall determine whether approve a waste is acceptable for

codisposal based on the potential for the waste to increase the quantity or toxicity of in a municipal solid waste combustor ash disposal facility only if the commissioner determines that codisposal of that waste will not significantly increase the movement of leachate generated at the facility, to cause failure of engineered systems such as the liner and leachate collection system, or to increase potential for which contaminates outside the codisposal ash phase by leakage, leaching, or fugitive dust emissions.

Subp. 4. **Limitation of leachable contaminants.** After January 1, 1993, the owner or operator of a waste combustor ash land disposal facility may not dispose of ash which exceeds the maximum leachable contaminant levels of subpart 5, unless the facility design either meets or exceeds the requirements of subparts 10, item C, subitem (3); and 11, item O or P, or if the facility is a type II cell which meets or exceeds the requirements in part 7035.2915 and is approved prior to or during the nine-month period immediately following adoption of parts 7001.0040 to 7035.2915, whichever applies. Compliance with this subpart must be based on results of testing ash using EPA Method 1312 as required by part 7035.2910, except as provided by items B to D. Alternatively, the commissioner may approve treatment within the land disposal facility if treatment reduces contaminant mobility so that any pollutants detected in leachate will not exceed the maximum leachable contaminant levels of subpart 5. A request for approval of an in-place treatment method must include results of a pilot scale demonstration of the effectiveness of the treatment method.

A. For the purpose of this subpart, "results" means the upper 80 percent confidence limit of a rolling data set consisting of results of EPA Method 1312, or actual leachate according to items B and C, calculated as specified in subpart 2, item B, subitem (4)- follows:

(1) the rolling data set must consist of results of the specified test for the preceding 12 months, or the time period since a change was made in waste combusted, waste combustor operations, or ash processing which significantly alters ash quality, whichever time period is shorter;

(2) if data from only one quarter are used to calculate results, the owner or operator must calculate the upper 80 percent confidence limit for the data using equations for random sampling shown in Table 9-1 of EPA SW-846. Part 7035.0605 incorporates this document by reference and establishes its availability; and

(3) if data from two or more quarters are used to calculate results, the owner or operator must calculate the upper 80 percent confidence limit for the data using equations for stratified random sampling shown in Table 9-1 of EPA SW-846, using each quarter as a stratum. The fraction of the population represented by each stratum ( $W_i$ ) must be selected based on the number of quarters of data to be used and the relative amounts of ash produced during each quarter.

B. The owner or operator may calculate results as required by item A using actual leachate analyses rather than EPA Method 1312 analyses for ash from a given waste combustor for one or more quarters if the following conditions are all true:

(4) the leachate analyzed was collected during the quarter and more than 60 days after collection of leachate samples which are also used to calculate results to determine compliance with this part; and

(5) samples used to calculate results for consecutive quarters were collected at least 60 days apart; and

(6) the leachate samples were collected according to a water quality and leachate monitoring protocol approved by the commissioner as part of the operations manual required under parts 7001.3480, item G; and 7035.2815, subpart 14, item G.

C. If a municipal solid waste combustor ash land disposal facility has a cell which contains 90 percent or more ash from only one waste combustor, and analyses of actual leachate samples from that cell exceeds EPA Method 1312 analyses of ash samples collected during the same quarter, actual leachate analyses must be used in place of EPA Method 1312 ash analyses for that quarter for calculating results to determine compliance with this subpart. If results of testing leachate as required by subpart 16, item B, exceed the maximum leachable contaminant levels of subpart 5, all new portions of the land disposal facility which accept ash from the same waste combustor or waste combustors must comply with the final cover requirements of subpart 10, item C, subitem (3), and the liner requirements of subpart 11, item O. If results of testing leachate as required by subpart 16, item B, exceed the maximum concentration of contaminants for characteristic of extraction procedure (EP) toxicity established in part 7045.0131, subpart 8, all new portions of the land disposal facility which accept ash from the same waste combustor or waste combustors must comply with the final cover requirements of subpart 10, item C, subitem (3), and the liner requirements of subpart 11, item P. For the purpose of this item, "results" means the upper 80 percent confidence limit of a rolling data set consisting of results of leachate testing for the preceding 12 months. The upper 80 percent confidence limit must be calculated using the equations presented in subpart 3, item A, subitems (1) to (3). The commissioner may approve an exemption from this part if the owner or operator demonstrates that the leachate produced in a new portion of the facility may reasonably be expected to not exceed the limits cited in this subpart, based on changes made such as pretreatment of ash prior to disposal.

KEY: PROPOSED RULES SECTION — Underlining indicates additions to existing rule language. Strike outs indicate deletions from existing rule language. If a proposed rule is totally new, it is designated "all new material." ADOPTED RULES SECTION — Underlining indicates additions to proposed rule language. Strike outs indicate deletions from proposed rule language.

## Adopted Rules

E. A municipal solid waste combustor ash land disposal facility which accepts ash from a waste combustor which has not been tested completed four or more quarters of ash testing according to part 7035.2910, must place the ash over a liner that complies at a minimum with the design requirements of subpart 11, item ~~Θ~~ P, unless:

(2) the owner or operator demonstrates, based on ash testing data from a similar waste combustor, where similarity is based on design, operation, and characteristics of waste combusted, that the ash which has not been tested is not likely to exceed the maximum leachable contaminant levels of subpart 5, and the ash is placed over a liner which complies with the design requirements of subpart 11, item L, ~~M~~, or N, whichever applies to the type of ash to be disposed of. If this subitem applies, the ash must be considered in storage and the commissioner shall not approve disposal of the ash until four quarters of ash and leachate testing have been completed. If results of ash or leachate testing for the four quarters exceed the maximum leachable contaminant levels, ~~the commissioner may require that~~ the ash must be removed from the land disposal facility. For the purpose of this subitem results must be calculated according to subpart 4, item A, subitems (1) to (3).

Subp. 5. **Maximum leachable contaminant levels.** The maximum leachable contaminant levels are as follows:

| Substance | Maximum leachable<br>contaminant level (mg/l) |
|-----------|---|
| Arsenic   | 750   |
| Barium    | 30,000  |
| Boron     | 9,000   |
| Cadmium   | 60  |
| Chromium  | <del>450</del> <u>1,500</u>                   |
| Copper    | 15,000  |
| Lead      | 300   |
| Manganese | 9,000   |
| Mercury   | 30  |
| Nickel    | 2,100   |
| Selenium  | 300   |
| Silver    | 300   |
| Tin       | 60,000  |
| Zinc      | 21,000  |

Subp. 10. **Cover system.** The owner or operator must design and maintain a cover system capable of minimizing infiltration of precipitation into the fill areas, preventing surface water ponding on fill areas, preventing erosion of surface and side slopes, minimizing the creation and movement of dust, retaining slope stability, reducing effects of freeze-thaw and other weather conditions, maintaining vegetative growth while minimizing root penetration of the low permeability cover layer, discouraging vector and burrowing animal intrusion into the site, and attenuating contaminants contained in leachate. A complete cover system must consist of intermittent, intermediate, and final covers as outlined in items A to C.

A. The owner or operator must place intermittent cover on all exposed ash according to the approved operation and maintenance manual for the site and subitems (1) to (4). In all cases, intermittent cover placement must be adequate to prevent fugitive dust emissions.

C. The owner or operator must place final cover according to the requirements of subitems (1) to (3) and part 7035.2815, subpart 6, item D, subitems (1), (2), and (6) to (9). A final cover system must consist of at least three layers: a barrier layer, a drainage layer, and a top layer.

(1) If the final cover uses a barrier layer constructed of soils or similar materials, the barrier layer must be at least 24 inches thick. The barrier layer must have a maximum permeability no greater than  $1 \times 10^{-6}$  centimeters per second. At least the top six inches after compaction of a barrier layer must not contain waste products which could contaminate water collected by the drainage layer. The drainage layer must be at least six inches thick and have an in-place permeability no less than  $1 \times 10^{-2}$  centimeters per second. The top layer must be at least 42 inches thick, of which at least the top six inches is topsoil, and of sufficient depth to contain the vegetative roots and protect the barrier layer from freezing. The top layer must have an available water-holding capacity that will promote vegetative growth. An alternative cover system may be approved by the commissioner if the owner or operator demonstrates that the barrier layer will be at least 24 inches thick, constructed of soils or similar materials, and have a maximum permeability no greater than  $1 \times 10^{-7}$  centimeters per second. The top layer of the alternative cover system must be at least 18 inches thick.

(3) According to subpart 4, if results of testing the specific combined, bottom, or fly ash which is placed in the land disposal facility phase to be covered or results of analysis of actual leachate from the phase exceed the maximum leachable contaminant levels established under subpart 5, the final cover system must consist of:

Subp. 11. **Liners.** All waste combustor ash land disposal facilities must be lined. A liner installed at a waste combustor ash land disposal facility after the effective date of ~~these rules~~ parts 7001.0040 to 7035.2915, unless otherwise allowed by part 7035.2915,

subpart 4, must meet the requirements of items A to K and part 7035.2815, subpart 7, items B, C, F, G, I, K, L, M, and N. In addition, waste combustor ash land disposal facilities must comply with the design standards of item L, M, N, O, or P, based on the requirements identified in Table 1.

**Table 1: Identification of Applicable Liner Design Standards**

|                                | Bottom Ash            | Combined Ash           | Fly Ash |
|--------------------------------|-----------------------|------------------------|---------|
| <b>Before Jan. 1, 1993:</b>    |                       |                        |         |
| (1) Leach results < MLCL       | L                     | <del>M</del> <u>N*</u> | N       |
| (2) MLCLF < Leach Results < EP | <del>L</del> <u>M</u> | <del>M</del> <u>N*</u> | P       |
| (3) Leach Results > EP         | <del>L</del> <u>O</u> | <del>M</del> <u>O*</u> | P       |
| <b>After Jan. 1, 1993:</b>     |                       |                        |         |
| (1) Leach results < MLCL       | L                     | <del>M</del> <u>N*</u> | N       |
| (2) MLCL < Leach results < EP  | O                     | <del>O</del> <u>P*</u> | P       |
| (3) Leach Results > EP         | P                     | <del>P</del> <u>P*</u> | P       |

\*Leach results must be taken from fly ash only.

Key: Leach results must be determined according to subpart 4.

MLCL means the maximum leachable contaminant levels established in subpart 5.

EP means the maximum concentration of contaminants for characteristic of extraction procedure (EP) the toxicity characteristic established in part 7045.0131, subpart 8, as tested according to subpart 4.

L. The liner of a ~~bottom~~ an ash land disposal facility, required by table 1 to meet the requirements of this item, must comply with subitems (1) to (3); ~~unless item O or P applies~~.

M. The liner of a ~~combined~~ an ash land disposal facility, required by table 1 to meet the requirements of this item, must comply with subitems (1) to (3); ~~unless item O or P applies~~.

N. The liner of a ~~fly~~ an ash land disposal facility, required by table 1 to meet the requirements of this item, which accepts ash which does not exceed the maximum leachable contaminant levels of subpart 5 must comply with subitems (1) to (3).

(1) The barrier layer must be a composite liner which includes a synthetic membrane which is at least 60/1000 of an inch thick placed over a layer of recompacted clay or other natural soil layer material with a permeability of no more than 1x10<sup>-7</sup> centimeters per second which is at least three feet thick.

P. The liner of a waste combustor ash land disposal facility that accepts fly ash which exceeds the maximum leachable contaminant levels of subpart 5, or bottom or combined ash which exceeds the maximum concentration of contaminants for characteristic of extraction procedure (EP) toxicity established in part 7045.0131, subpart 8, must comply with subitems (1) to (3).

(1) The liner must be a double ~~composite~~ composite liner which includes at a minimum, from top to bottom:

(c) ~~a recompacted soil layer which is at least two feet thick with a permeability no greater than 1x10<sup>-7</sup> centimeters per second;~~

(~~d~~) a secondary drainage layer which complies with item H;

(~~e~~) (d) a synthetic membrane which is at least 30/1000 of an inch thick; and

(~~f~~) (e) a ~~recompacted~~ compacted clay layer which is at least ~~two~~ three feet thick with a permeability no greater than 1x10<sup>-7</sup> centimeters per second.

Subp. 15. **Operation and maintenance requirements.** The owner or operator must operate the facility according to items A to V.

T. The liner must be protected from freezing. At least three feet of ash or other approved material must be placed above the sand blanket on all lined areas by December 1 of each year to protect the liner from freezing. No disposal may take place after December 1 in areas which have not met this requirement without first testing the liner integrity and receiving approval from the commissioner for the disposal.

Subp. 16. **Ground water, surface water, and leachate sampling and analysis.** The owner or operator must design, install, and maintain a water monitoring system in compliance with part 7035.2815, subpart 10. The owner or operator must collect and analyze

**KEY: PROPOSED RULES SECTION** — Underlining indicates additions to existing rule language. ~~Strike outs~~ indicate deletions from existing rule language. If a proposed rule is totally new, it is designated "all new material." **ADOPTED RULES SECTION** — Underlining indicates additions to proposed rule language. ~~Strike outs~~ indicate deletions from proposed rule language.

## Adopted Rules

groundwater samples, leachate samples and, where required in permits, orders, or stipulation agreements, surface water samples, according to part 7035.2815, subpart 14, items A, B, and D to Q.

Until the commissioner has established facility-specific monitoring requirements as required by part 7035.2815, subpart 14, item B, the owner or operator must comply with the monitoring requirements of items A and B.

A. Groundwater quality monitoring points at the facility must be sampled at least three times per year at the times specified in the facility permit. For one of the three sampling events, the owner or operator must provide the field measurements, laboratory analysis, and field and laboratory observations listed in subitems (1) and (2). For the other two sampling events, the owner or operator must provide only the measurements and observations listed in subitem (1) for all groundwater monitoring points. Where existing monitoring points may be unsuitable for sampling some or all of the listed substances, the commissioner may make appropriate changes in the monitoring requirements.

(2) Extended list of groundwater parameters:

(f) Other parameters listed in item B required by the commissioner based on their detection in leachate

### 7035.2910 MUNICIPAL WASTE COMBUSTOR ASH TESTING REQUIREMENTS.

Subp. 4. **Test methods.** The owner or operator must analyze samples for total composition, leaching potential, and physical characteristics for the following testing parameters, using test methods issued by the United States Environmental Protection Agency or the American Society of Testing and Materials unless the method is approved as provided by item D. The test methods must obtain detection limits equal to or less than those specified in this subpart.

B. Leaching potential: use EPA Method 1312, the Synthetic Precipitation Leach Test for Soils, with extraction fluid no. 2 (pH = 5.0) to satisfy the leaching potential testing requirements of this part.

(1) Table 1: Quarterly Testing Parameters:

| Parameter  | Maximum<br>Detection Limit |
|--|----------------------------|
| (a) Aluminum   | 1000 µg/l                  |
| (b) Arsenic  | 25 µg/l                    |
| (c) Cadmium  | 4 µg/l                     |
| (d) Lead   | 20 µg/l                    |
| (e) Manganese  | 20 µg/l                    |
| (f) Mercury  | 2 µg/l                     |
| (g) Nickel   | 20 µg/l                    |
| (h) Selenium   | 20 µg/l                    |
| (i) Zinc   | 20 µg/l                    |
| (j) pH of ash and of<br>leachate produced by<br>the leach test   | +/-0.1 pH units            |
| (k) Other parameters listed in subitem (2) which are<br>required by the commissioner based on results of previous testing. |                            |

Subp. 5. **Number of analyses.** ~~Unless bottom ash and fly ash are mixed as part of an internal, mechanical process,~~ The owner or operator must collect and analyze fly ash and bottom ash samples separately according to item A. In cases where bottom and fly ash are mixed, collect and analyze samples of combined ash according to item B, and fly ash samples according to item A. If ash treatment occurs prior to disposal, collect samples after treatment.

Subp. 8. **Sample collection methods.** Methods used to collect samples to satisfy the requirements of this part must comply with items A to H.

F. Grab samples must be collected according to subitems (1) to (3). Analysis samples must be taken from composite samples formed by processing and mixing grab samples according to subpart 9.

(3) Grab samples must be collected of approximately equal ~~volume~~ weight. Grab samples of bottom ash or combined ash must consist of a minimum of 15 pounds (seven kilograms) of ash. Grab samples of fly ash must consist of a minimum of one pound (one-half kilogram) of ash if the waste combustor produces less than ten tons of fly ash in one week, and two pounds (one kilogram) of ash if the waste combustor produces ten tons or more of fly ash per week.

Subp. 10. **Annual ash testing report.** The owner or operator must submit an annual ash testing report to the commissioner by March 15 of each year. The report must include the information in items A to F.

B. Discussion of the data, including identification of trends observed by comparing the most recent year's results with those

of previous years. In particular, the owner or operator must assess whether the waste combustor is in compliance with the goals of Minnesota Statutes, section 115A.97, subdivision 1, clause (1.)

D. Information summarizing operation of the waste combustor during the ash sampling periods, and data regarding ash sample processing recorded according to subpart 9. Operating information must include an estimate of the quantity and type of wastes other than mixed municipal solid waste which were combusted at the facility during the ash sampling period. If leachate was added to the waste during the sampling period, the quantity of leachate added and source of the leachate must be noted.

~~Subp. 12. Requirements for exemption from part 7035.2885. Owners and operators of waste combustors who apply for exemption from the ash disposal requirements of part 7035.2885 using the exemption process described in part 7035.2885, subpart 2, must comply with the ash testing requirements of this subpart.~~

~~A. If part 7035.2885, subpart 2, item B, subitem (3) applies, in addition to the testing required under subparts 4 and 5, the owner or operator must analyze quarterly, using EPA Method 1311, the Toxicity Characteristic Leaching Procedure, a minimum of six samples of each type of ash (bottom, fly, or combined) which is to be exempted.~~

~~B. The owner or operator must submit the results of the testing required by item A to the commissioner as part of the annual report required by subpart 10.~~

~~C. The owner or operator must notify the commissioner within 48 hours after the owner or operator determines that the results of testing ash as required by item A or subparts 4 and 5 exceed the limits identified in part 7035.2885, subpart 2.~~

#### **7035.2915 REQUIREMENTS FOR TEMPORARY PROGRAM TYPE I and II STORAGE FACILITIES.**

Subp. 3. **Type I ash storage facilities.** The owner or operator must design, maintain, and operate a type I ash storage facility in compliance with item A. Type I ash storage facilities must be closed in compliance with item B.

A. The owner or operator must design, maintain, and operate a type I ash storage facility in compliance with the solid waste storage facility requirements of part 7035.2855, subparts 3 and 4, excluding subpart 4, item B, the requirements of the facility permit, and applicable parts of the temporary program.

B. Within 18 months after the effective date of this part the owner or operator must close a type I ash storage facility according to parts 14 and 15 of the temporary program, the facility permit, the site closure plan and subitems (1) to (4); ~~or according to a closure document approved by the commissioner under part 7001.3055.~~ In cases where requirements of the aforementioned documents conflict with each other, the most recent requirements shall apply.

Subp. 4. **Type II ash storage facilities.** Type II ash storage facilities are classified as municipal solid waste combustor ash land disposal facilities. As such, all operations and new construction other than liner or final cover construction must comply with part 7035.2885 and all other applicable parts of this chapter within 45 days after the effective date of this part. Liners and final cover constructed more than nine months after the effective date of this part must meet the requirements of part 7035.2885. At least nine months before the anticipated date for beginning construction of a new ~~cell~~ phase at the facility the owner or operator of a type II ash storage facility must submit to the commissioner for review and approval amendments to the facility's approved engineering plans, engineering reports, and operations manual showing changes necessary to comply with part 7035.2885.

---

---

## **Executive Orders**

### **Executive Department**

#### **Executive Order 92-5: Providing for Administration of Technology Related Assistance for Individuals with Disabilities**

I, ARNE H. CARLSON, GOVERNOR OF THE STATE OF MINNESOTA, by virtue of the authority vested in me by the Constitution and the applicable statutes, do hereby issue this Executive Order:

WHEREAS, the Governor's Advisory Council on Technology for People with Disabilities has been a

**KEY: PROPOSED RULES SECTION** — Underlining indicates additions to existing rule language. ~~Strike outs~~ indicate deletions from existing rule language. If a proposed rule is totally new, it is designated "all new material." **ADOPTED RULES SECTION** — Underlining indicates additions to proposed rule language. ~~Strike outs~~ indicate deletions from proposed rule language.

## Executive Orders

---

---

national model of public and private sector cooperation in planning for technology-related assistance for individuals with disabilities; and

**WHEREAS**, Minnesota intends to present a funding proposal to the U.S. Department of Education in order to advance Minnesota's leadership in assistive technology and services; and

**WHEREAS**, the 1991 Minnesota Legislature transferred the Governor's Advisory Council on Technology for People with Disabilities to the Minnesota Department of Administration;

**NOW, THEREFORE**, I hereby order that:

1. The Department of Administration shall serve as the lead agency to prepare Minnesota's application for funds under the federal Technology-Related Assistance for Individuals with Disabilities Act, Title I, state grants program.

2. The Governor's Advisory Council on Technology for People with Disabilities shall be continued and shall assist the Department of Administration to prepare and carry out Minnesota's proposal for U.S. Department of Education funds. The council shall consist of fourteen members and a chair to be appointed by the Governor according to *Minnesota Statutes* 1990, Section 15.059. Members shall be appointed from consumers, service agencies, the private sector, third-party funding sources, education and library systems. Ex officio members shall include the commissioners of Human Services, Jobs and Training, Education, and the Office of Strategic and Long Range Planning, the Chancellor of the State University System, and the Chair of the Council on Disability or their designees.

3. The Department of Administration, with the assistance of the Governor's Advisory Council on Technology for People with Disabilities shall:

a. Develop and administer a comprehensive, consumer-responsive system of assistive technology devices and services for individuals with disabilities;

b. Prepare, in accordance with 34 CFR Part 345, the federal grant application under the U.S. Technology-Related Assistance for Individuals with Disabilities Act, Title I, state grants program;

c. Coordinate the involvement of state agencies in the provision of technology-related services;

d. Ensure individual and family involvement in the development, implementation and evaluation of services;

e. Advise the Governor on policy issues related to technology-related assistance to individuals with disabilities.

Pursuant to *Minnesota Statutes* 1990, Section 4.035, subd. 2, this Order shall be effective fifteen (15) days after publication in the *State Register* and filing with the Secretary of State and shall remain in effect until rescinded by proper authority or it expires in accordance with *Minnesota Statutes* 1990, Section 4.035, subd. 3.

**IN TESTIMONY WHEREOF**, I have set my hand this tenth day of April, 1992.

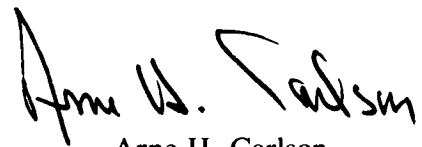
  
Arne H. Carlson  
Governor

Filed According to Law:

Joan Anderson Growe  
Secretary of State

Dated: 10 April 1992



# Commissioners' Orders

## Department of Natural Resources

### Commissioner's Order No. 2439: Regulations for the Taking of Bear During 1992

PURSUANT TO AUTHORITY vested in me by *Minnesota Statutes* §§ 97B.401-.431 and other applicable law, I, Rodney W. Sando, Commissioner of Natural Resources, hereby prescribe the following regulations for the taking of bear during 1992. All dates and time periods specified in this order are inclusive unless otherwise noted.

#### Section 1. DEFINITIONS.

(a) Legal firearms. A firearm or ammunition may be used to take bear if it meets the following requirements:

- (1) Handguns, rifles, shotguns, and all projectiles used therein shall be at least 23/100ths of an inch in caliber;
- (2) All firearms shall be loaded only with ammunition containing single projectiles;
- (3) All projectiles shall be of a soft point or an expanding bullet type;
- (4) All ammunition shall have a case length of at least 1.285 inches except that 10 millimeter cartridges shall be at least 0.95 inches in length; and
- (5) Muzzleloaders must be incapable of being loaded at the breech. Smooth-bore muzzleloaders shall be at least .45 caliber and rifled muzzleloaders shall be at least .40 caliber.

It is unlawful to take bear with a .30 caliber M-1 carbine cartridge or with any other firearm or ammunition which does not meet the requirements set forth in this section.

(b) Legal bow and arrow. Bows must have a pull of no less than 40 pounds at or before full draw. Arrowheads used for taking big game must be sharp and have a minimum of two metal cutting edges, be of a barbless broadhead design, and must have a diameter of at least 7/8ths inch. It is unlawful to take bear with any poisoned arrow or arrow with explosive tip. A person may not hunt with a bow drawn, held, or released by a mechanical device, except that a person may use a mechanical device attached to the bowstring if the person's own strength draws, holds, and releases the bowstring.

(c) Drawings. Computerized random drawings will be conducted by the Department of Natural Resources to determine those who will be eligible to apply for a bear license within the bear permit areas. Preference in the drawings will be given to applicants based upon the number of times they have correctly applied for a permit in previous years but have been unsuccessful in the drawing. Obtaining a no-quota bear license will have no effect upon eligibility or preference in the drawings except that no person may purchase more than one bear license in a calendar year.

(d) No-quota area. That part of the State of Minnesota not included within the boundaries of permit areas described in Sec. 3.

(e) Bear bait. Bear bait means any materials placed for the purpose of attracting or attempting to attract bear.

(f) Bear bait station. Bear bait station means any location at which bait is placed for the purpose of hunting. This definition shall not be construed to include a garbage dump or materials that are at all times attended by the hunter.

(g) Garbage dump. Garbage dump means any site regularly and primarily used for the disposal of garbage or other refuse. This definition shall not be construed to include a bear bait station.

#### Sec. 2. BEAR HUNT DRAWING AND LICENSING.

(a) Persons desiring to hunt bear have a choice of two means of obtaining a bear license. Persons desiring to hunt within one of the permit areas described in Sec. 3 and subject to the quotas set forth in Sec. 4 must take part in the license application drawing. Persons desiring to hunt in the no-quota area outside of the permit areas described in Sec. 3 do not have to participate in a drawing and may purchase a bear license from a county auditor's office, license vendors in Pine, Kanabec, Roseau, and Marshall Counties, or the DNR License Bureau in St. Paul. No person may hunt bear without having first obtained a bear hunting license. A person obtaining a bear license for a permit area is restricted to hunting bear within the permit area for which the license is issued. A person obtaining a bear license for the no-quota area is restricted to hunting bear outside of the permit areas.

(b) Any resident or nonresident who is at least 12 years old prior to September 1, 1992 and whose big game hunting privileges are not suspended pursuant to *Minnesota Statutes* § 97A.421 is eligible to purchase a bear license for the no-quota area or to enter a drawing for a permit area license. Persons under the age of 16 must possess a valid Firearms Safety Certificate to obtain a license.

(c) Application for the drawing must be made on the form provided by the Department of Natural Resources and all information requested must be supplied. All applicants who have reached their 18th birthday by May 1, 1992 must provide their driver's license number, an official State of Minnesota identification number issued by the Department of Public Safety, or a 13-digit Firearms Safety Certificate number. Applicants under age 18 who do not submit an identification number will have a number automatically assigned and will be entered into the drawing.

## Commissioners' Orders

---

---

(d) Each permit area applicant may apply only once and for only one of the permit areas. Any person who submits more than one such application in any one year shall be ineligible to receive a bear license in that year and shall be guilty of a misdemeanor. Improperly completed applications will be rejected.

(e) Applications must be returned to the DNR License Bureau, Box 26 DNR Building, 500 Lafayette Rd., St. Paul, MN 55155-4026. If mailed, applications must be submitted in envelopes and postmarked no later than May 1, 1992. If hand-delivered applications must be delivered no later than 4:30 p.m., May 1, 1992.

(f) Persons may apply individually or as part of a group totaling no more than four persons. Those who wish to apply as a group must submit their applications for the drawing together in one envelope. All applications in a group must be for the same permit area. The individual within a group with the lowest preference rating will determine the preference rating of the group. Either all members of the group will be drawn or none will. Improperly completed applications will be rejected but will not disqualify other members of the group.

(g) Successful drawing applicants will receive a license application with instructions for obtaining their licenses. Successful applicants who do not return the license application and the fee according to the provisions specified on the license application or who do not provide all of the requested information will be disqualified. All accumulated preference is lost upon issuance of a bear hunting license. Licenses for the quota bear permit areas shall not be issued to successful drawing applicants after the hunting permit selection process.

### Sec. 3. BEAR HUNT PERMIT AREAS.

#### (a) Bear Hunt Permit Area 12.

That portion of the state lying within the following described boundary:

Beginning at the intersection of State Trunk Highway (STH) 72 and the north boundary of the state; thence along STH 72 to the Tamarac River; thence along the south shore of said river to Upper Red Lake; thence along the southeast shore of said lake to the east boundary of the Red Lake Indian Reservation; thence along the east, south, and west boundaries of said Reservation to the point where the Clearwater River leaves the Reservation boundary; thence along the south shore of said river to County State Aid Highway (CSAH) 2, Polk County; thence along CSAH 2 to CSAH 27, Pennington County; thence along CSAH 27 to STH 1; thence along STH 1 to CSAH 28, Pennington County; thence along CSAH 28 to CSAH 54, Marshall County; thence along CSAH 54 to CSAH 9, Roseau County; thence along CSAH 9 to CSAH 2, Roseau County; thence along CSAH 2 to STH 89; thence along STH 89 to STH 310; thence along STH 310 to the north boundary of the state; thence along the north boundary of the state to the point of beginning.

#### (b) Bear Hunt Permit Area 13.

That portion of the state lying within the following described boundary:

Beginning on the north boundary of the state at State Trunk Highway (STH) 72; thence along the north boundary of the state to a point due north of the intersection of STH 11 and U.S. Highway 71; thence due south to U.S. Highway 71; thence along U.S. Highway 71 to STH 6; thence along STH 6 to STH 1; thence along STH 1 to STH 72; thence north along STH 72 to the point of beginning.

#### (c) Bear Hunt Permit Area 22.

That portion of the state known as the Boundary Waters Canoe Area Wilderness (BWCAW) but excluding the detached part of the BWCAW lying south of the Echo Trail, St. Louis County, and known as the Trout Lake unit or block.

#### (d) Bear Hunt Permit Area 24.

That portion of the state lying within the following described boundary:

Beginning at the junction of U.S. Highway 2 and State Trunk Highway (STH) 65; thence along STH 65 to STH 1; thence along STH 1 to the Soudan-Two Harbors Branch of the Duluth, Missabe and Iron Range Railway Company (DM&IR); thence along said railroad to County State Aid Highway (CSAH) 16, St. Louis County; thence along CSAH 16 to U.S. Highway 53; thence along U.S. Highway 53 to CSAH 133, St. Louis County; thence along CSAH 133 to CSAH 25, Itasca County; thence along CSAH 25 to U.S. Highway 2; thence along U.S. Highway 2 to the point of beginning.

#### (e) Bear Hunt Permit Area 25.

That portion of the state lying within the following described boundary:

Beginning at the junction of State Trunk Highway (STH) 1 and STH 65; thence along STH 1 to STH 169; thence along STH 169 to the first Shagawa River bridge at Winton; thence along the north shore of said river to Fall Lake; thence along the west and north shores of Fall Lake to the south boundary of the Boundary Waters Canoe Area Wilderness (BWCAW); thence west along the south boundary of the BWCAW to the intersection with the north boundary of the state; thence along the north boundary of the

state to a point due north of the junction of U.S. Highway 71 and STH 11 at Pelland; thence due south to said junction; thence along U.S. Highway 71 to STH 6; thence along STH 6 to STH 1; thence along STH 1 to the point of beginning.

(f) Bear Hunt Permit Area 26.

That portion of the state lying within the following described boundary:

Beginning at the junction of U.S. Highway 2 and State Trunk Highway (STH) 65; thence along STH 65 to STH 1; thence along STH 1 to STH 72; thence along STH 72 to U.S. Highway 71; thence along U.S. Highway 71 to U.S. Highway 2; thence along U.S. Highway 2 to the point of beginning.

(g) Bear Hunt Permit Area 31.

That portion of the state lying within the following described boundary:

Beginning on U.S. Highway 53 at the east boundary of the state; thence along U.S. Highway 53 to County State Aid Highway (CSAH) 16, St. Louis County; thence along CSAH 16 to the Soudan-Two Harbors Branch of the Duluth, Missabe and Iron Range Railway Company (DM&IR); thence along said railroad to State Trunk Highway (STH) 169; thence along STH 169 to the first Shagawa River bridge at Winton; thence along the north shore of said river to Fall Lake; thence along the west and north shores of Fall Lake to the south boundary of the Boundary Waters Canoe Area Wilderness (BWCAW); thence east along said boundary of the BWCAW to the north boundary of the state at Magnetic Lake; thence east along the north boundary of the state to the boundary of the BWCAW on the south shore of North Lake; thence along the boundaries of this detached part of the BWCAW to the north boundary of the state at South Fowl Lake; thence along the north and east boundaries of the state to the point of beginning; EXCEPT that portion lying within the following described boundary is closed to bear hunting:

Beginning at the intersection of CSAH 16, Lake County and the east boundary of Township 62 North, Range 11 West; thence south along said boundary to the northeast corner of Township 61 North, Range 11 West; thence south along the east boundary of Township 61 North, Range 11 West to the north shore of Harris Lake; thence along the north shore of Harris Lake, Nira Creek, and Denley Creek to the east shore of Birch Lake; thence north along the east shore of Birch Lake to the south shore of the South Fork of the Kawishiwi River; thence along the south shore of the South Fork of the Kawishiwi River to the east boundary of Township 62 North, Range 11 West; thence south along said east boundary to the point of beginning.

(h) Bear Hunt Permit Area 41.

That portion of the state lying within the following described boundary:

Beginning at the junction of the north boundary of the White Earth Indian Reservation and County State Aid Highway (CSAH) 6, Polk County; thence along CSAH 6 to CSAH 3, Polk County; thence along CSAH 3 to CSAH 2, Polk County; thence along CSAH 2 to the Clearwater River; thence along the south shore of said river to the west boundary of the Red Lake Indian Reservation; thence along the west, south and east boundaries of said reservation to the southeast shore of Upper Red Lake; thence along said lakeshore to the Tamarac River; thence along the south shore of said river to State Trunk Highway (STH) 72; thence along STH 72 to U.S. Highway 71; thence along U.S. Highway 71 to U.S. Highway 2; thence along U.S. Highway 2 to STH 92; thence along STH 92 to the north boundary of the White Earth Indian Reservation; thence west along said reservation boundary to the point of beginning.

(i) Bear Hunt Permit Area 43.

That portion of the state lying within the following described boundary:

Beginning at the junction of U.S. Highway 59 and the north boundary of the White Earth Indian Reservation; thence along said boundary to State Trunk Highway (STH) 92; thence along STH 92 to U.S. Highway 2; thence along U.S. Highway 2 to STH 6; thence along STH 6 to STH 18; thence along STH 18 to U.S. Highway 169; thence along U.S. Highway 169 to STH 23; thence along STH 23 to the Mississippi River; thence upstream along the east shore of said river to STH 27 at Little Falls; thence along STH 27 to U.S. Highway 71; thence along U.S. Highway 71 to U.S. Highway 10; thence along U.S. Highway 10 to U.S. Highway 59; thence along U.S. Highway 59 to the point of beginning.

The Tamarac National Wildlife Refuge within Area 43 is not open for bear hunting.

(j) Bear Hunt Permit Area 51.

That portion of the state lying within the following described boundary:

Beginning on U.S. Highway 53 on the east boundary of the state; thence along U.S. Highway 53 to County State Aid Highway (CSAH) 133, St. Louis County; thence along CSAH 133 to CSAH 25, Itasca County; thence along CSAH 25 to U.S. Highway 2; thence along U.S. Highway 2 to State Trunk Highway (STH) 6; thence along STH 6 to STH 18; thence along STH 18 to U.S. Highway 169; thence along U.S. Highway 169 to STH 23; thence along STH 23 to STH 47; thence along STH 47 to STH 27; thence along STH 27 to STH 65; thence along STH 65 to STH 18; thence along STH 18 to the west boundary of Pine County; thence along the west and north boundaries of Pine County to STH 23; thence along STH 23 to CSAH 22, Pine County; thence along CSAH 22

# Commissioners' Orders

---

---

to CSAH 32; thence along CSAH 32 to the east boundary of the state; thence along the east boundary of the state to the point of beginning.

## Sec. 4. BEAR HUNT PERMIT AREA QUOTAS.

The following quotas on hunter numbers are established for each bear hunt permit area:

| <u>Permit Area</u> | <u>Quota</u> |
|--------------------|--------------|
| 12                 | 350          |
| 13                 | 340          |
| 22 (BWCAW)         | 280          |
| 24                 | 680          |
| 25                 | 830          |
| 26                 | 950          |
| 31                 | 1,160        |
| 41                 | 380          |
| 43                 | 1,340        |
| 51                 | <u>1,610</u> |
| TOTAL              | 7,920        |

The quota of licenses listed for any permit area may be modified in order to accommodate party members if the last applicant to be selected is a member of a party.

## Sec. 5. SEASON DATES, METHODS, AND HOURS.

Bear may be taken by licensed hunters using legal firearms or legal bow and arrow from September 1 to October 18, 1992 in all permit areas and in the no-quota area between one-half hour before sunrise and sunset each day. However, no person shall hunt bear while having in possession or having under control both a firearm and a bow and arrow. Each hunter may hunt only within the permit area designated on his or her license.

## Sec. 6. NUISANCE BEAR.

Nuisance bear may be taken under special permit by licensed bear hunters from July 1, 1992 to August 31, 1992, between one-half hour before sunrise and sunset each day, pursuant to the following conditions:

(1) Permits shall be issued by a conservation officer on a case-by-case basis only after the conservation officer has determined that a nuisance bear problem does in fact exist, and that no practical alternatives to killing the bear exist for alleviating the problem.

(2) Permits shall be issued to hunters with licenses valid for the permit area in which the damage is occurring. Permits issued for nuisance bears outside the permit areas shall be issued only to hunters with valid licenses for the no-quota area. Only one hunter shall hunt under any one permit. Each permit shall be restricted to a specified location.

(3) Any person taking a bear pursuant to this section shall register it with the officer who issued the permit (or his/her designee) within 48 hours after taking.

(4) Anyone who kills a bear pursuant to this section shall not kill, hunt, or tag another bear during 1992.

(5) Nuisance bear permittees are subject to all provisions of this order not inconsistent with this section and all laws relating to the taking of wild animals.

## Sec. 7. BAG LIMIT.

(a) No person shall take more than one bear during any calendar year whether by firearm or bow and arrow. Bear taken may be of either sex or any age except that cub bear may not be taken. Cub bear are any bear less than one year of age.

(b) Party hunting for bear is not permitted. No hunter shall affix the locking seal provided with his or her license to a bear which he or she did not kill. No hunter shall affix to a bear the locking seal of another hunter. No hunter shall kill a bear for another hunter.

## Sec. 8. BEAR BAIT STATIONS AND GARBAGE DUMPS.

(a) No person shall establish, service, or maintain any bait station prior to August 14, 1992.

(b) No person shall establish a bait station without registering the site as follows:

(1) The following information must be provided on the preprinted form provided with the license or on an 8½ inch by 11 inch sheet of paper:

(A) Name, address, and telephone number of person who established the bait station.

(B) County, township, range and section in which the bait station is established.

(2) The above information must be mailed no later than the next postal service day following establishment of the bait station to the Division of Enforcement, Department of Natural Resources, Box 47 DNR Building, 500 Lafayette Rd., St. Paul, MN 55155-4047.

(c) Any person establishing a bait station shall display a sign at the site as follows:

(1) The sign shall be made of plastic, wood, or metal and shall be at least 6 inches by 10 inches in size.

(2) The sign shall contain the full name and Minnesota driver's license number or the full name, address, and telephone number, all in the English language, of the person placing the bait.

(3) Letters and numbers shall be legibly printed and either painted or impressed on the sign material.

(4) The sign shall be prominently displayed between 6 and 10 feet above the natural ground level and within 20 feet of the bait.

(5) Signs must be removed within 48 hours of the close of the bear season and shall not be displayed before the following year's bait station establishment date.

(d) No person shall hunt bear within 100 yards of a bait station unless it is registered and marked with a sign as prescribed by this section.

(e) To attract bear, a person may not use a bait with:

(1) A carcass from a mammal, if the carcass contains more than 25 percent of the intact carcass;

(2) Meat from mammals, if the meat contains bones;

(3) Bones of mammals;

(4) Solid waste containing bottles, cans, plastic, paper, or metal;

(5) Materials that are not readily biodegradable; or

(6) Any part of a swine, except that cured bacon and ham may be used.

(f) No person shall take or attempt to take bear within one-half mile of a garbage dump, or designated municipal or county garbage collection point except as authorized pursuant to Sec. 6 of this order or as otherwise authorized by law. No person who is licensed to take bear may be in possession of an uncased weapon legal for taking bear while within one-half mile of any such location that has existed at any time within the preceding four months.

(g) No person shall establish a bait station within 150 yards of a campsite or in Bear Hunt Permit Area 22.

(h) No person shall establish a bait station within 500 yards of any site where bear bait has been placed prior to August 14, 1992.

#### Sec. 9. SPECIAL PROVISIONS.

(a) Locking seal. Every person killing a bear must affix to the carcass the locking seal provided with his or her bear hunting license. The seal must be fastened around the bear's sternum (breast bone) in such a way that the seal cannot be removed without breaking the lock.

(b) Registration. Every person taking a bear shall present it for registration at an official bear registration station or, in the case of a nuisance bear permit, to the issuing officer, within 48 hours after taking and obtain a Big Game Possession Tag. Prior to transporting the bear from the registration station the possession tag shall be attached to the bear in the same manner as the locking seal. Bear taken in the no-quota area must be registered within the no-quota area.

(c) Tooth and rib collection. Every person killing a bear must submit a bear tooth and rib sample to the Department of Natural Resources according to instructions, and in the envelope provided at bear registration stations. It is the responsibility of each person killing a bear to mail the envelope to the DNR except in those cases where a bear registration station is collecting the teeth and ribs.

(d) No person shall take or molest any bear in a den.

(e) No person shall take or attempt to take bear with the aid of dogs.

(f) No bear shall be taken in any manner in any area of the state except as herein expressly provided or as otherwise provided by commissioner's order or by law.

(g) None of the provisions of this order shall be construed as modifying or superseding any order establishing game refuges within the state nor as permitting the taking of any wild animals within such refuges or within state parks.

(h) All animals taken pursuant to this order must be killed before being removed from the site where taken.

(i) No licensed bear hunter may take a bear being studied under authority of a research permit issued by the commissioner if the

## Commissioners' Orders

---

---

permittee or his/her designee is accompanying the bear and has identified the bear to the hunter as a research animal.

Dated at St. Paul, Minnesota, this 1st day of April, 1992.

Rodney W. Sando, Commissioner  
Department of Natural Resources

## Revenue Notices

---

---

Effective July 1, 1991, the Department of Revenue has authority to issue revenue notices. A revenue notice is a policy statement made by the department that provides interpretation, details, or supplementary information concerning the application of law or rules. This authority was provided by the Legislature in 1991 Session Laws Chapter 291, article 21, section 6 and will be codified at *Minnesota Statutes* section 270.0604.

### Department of Revenue

#### Revenue Notice #92-12: Sales and Use Tax—Lawn, Garden, and Arborist Services and Landscaping Contracts

[This subject was originally discussed in Revenue Notice 91-2, Application of Sales and Use Tax to Lawn, Garden, and Arborist Services and Landscaping Contracts which was published in the *State Register* on July 29, 1991. This Revenue Notice clarifies some of the information from that Revenue Notice. This Revenue Notice supersedes Revenue Notice 91-2 to the extent that any of the information conflicts with information in Revenue Notice 91-2.]

The application of sales and use tax to lawn, garden, and arborist services is governed by *Minnesota Statutes* § 297A.01, subd. 3(j)(vi) and 297A.01, subd. 4. The Commissioner of Revenue has interpreted these provisions as follows:

Any tree or stump removal or stump grinding provided in connection with new construction, reconstruction, or remodeling of improvements to real property is not subject to the sales or use tax. The interpretation set forth in this Revenue Notice is effective for services provided on or after April 20, 1992.

Dated: 20 April 1992

## Official Notices

---

---

Pursuant to the provisions of *Minnesota Statutes* § 14.10, an agency, in preparing proposed rules, may seek information or opinion from sources outside the agency. Notices of intent to solicit outside opinion must be published in the *State Register* and all interested persons afforded the opportunity to submit data or views on the subject, either orally or in writing.

The *State Register* also publishes other official notices of state agencies, notices of meetings, and matters of public interest.

### Minnesota Comprehensive Health Association

#### Notice of Special Meeting of the Board of Directors

**NOTICE IS HEREBY GIVEN** that a meeting of the Minnesota Comprehensive Health Association (MCHA), Board of Directors will be held at 5:00 p.m. on Tuesday, April 21, 1992 at Blue Cross Blue Shield Minnesota, Yankee Place, 3500 Yankee Drive, Suite 400, Eagan, Minnesota, in Room A.

For additional information please call Lynn Gruber at (612) 593-9609.

### Minnesota Comprehensive Health Association

#### Notice of Nominating Committee Meeting

**NOTICE IS HEREBY GIVEN** that a meeting of the Nominating Committee of the Minnesota Comprehensive Health Association (MCHA), will convene at 3:30 p.m. on Tuesday, April 21, 1992 at Blue Cross Blue Shield of Minnesota, 3535 Blue Cross Road, Eagan, Minnesota, in the "Fish Bowl" room of the cafeteria.

For additional information please call Lynn Gruber at (612) 593-9609.

## **Department of Education**

### **Unique Learner Needs Section**

#### **Notice of Public Hearing on the Year IV B State Plan for Part H, PL 101-119**

**NOTICE IS HEREBY GIVEN** that the Minnesota Departments of Education, Health and Human Services seek public comment through a public hearing on the Year IV B State Plan for Part H, PL 101-119 for Infants and Toddlers Birth through Age Two with Disabilities and their Families. Notice is hereby given that a full, intact Year IV B State Plan may be requested by mail or picked up from the Interagency Early Intervention Project for Young Children with Disabilities, 826 Capitol Square Building, 550 Cedar St., St. Paul, MN 55101. A full intact Plan will also be available for public inspection at the hearing site. Written and oral comments may be sent to the Interagency Early Intervention Project for Young Children with Disabilities or they will be received at the public hearing listed below:

Rutgers Bay Lake Lodge and Conference Center  
Deerwood, MN 56444  
Thursday, April 30, 1992  
7:30-9:00 p.m.

## **Office of the Ombudsman for Mental Health and Mental Retardation**

### **Notice of Meeting**

The Ombudsman for Mental Health and Mental Retardation Advisory Committee will hold a general meeting at 9:00 a.m. on Friday, May 1, 1992. The meeting will be held at the Ombudsman Office, Suite 156, Metro Square Building on 7th and Robert Street, St. Paul.

## **Department of Revenue**

### **Appeals, Legal Services, and Criminal Investigation Division**

#### **Notice of Solicitation of Outside Information or Opinions Regarding Proposed Rules Governing Sale and Use of Admissions and the Use of Amusement Services**

**NOTICE IS HEREBY GIVEN** that the State Department of Revenue is seeking information or opinions from sources outside the agency in preparing a revised rule governing sales and use taxation of admissions and the use of amusement devices. The revised rule is authorized by *Minnesota Statutes*, section 270.06, clause (13), which permits the agency to make, publish, and distribute rules for the administration and enforcement of state tax laws.

The State Department of Revenue requests information and opinions concerning the subject matter of the rule. Interested persons or groups may submit data or views on the subject matter of concern in writing or orally. Written statements should be addressed to:

John E. Streiff  
Appeals, Legal Services, and  
Criminal Investigation Division  
10 River Park Plaza  
Mail Station 2220  
St. Paul, MN 55146-2220

Oral statements will be received during regular business hours over the telephone at (612) 296-1902 Extension 133 and in person at the above address.

All statements of information and opinions shall be accepted until May 25, 1992. Any written material received by the State Department of Revenue shall become part of the rulemaking record to be submitted to the Attorney General or Administrative Law Judge.

John E. Streiff

### Minnesota Rural Finance Authority

#### Notice of Public Hearing on the Issuance of an Agricultural Development Revenue Bond

**NOTICE IS HEREBY GIVEN** that a public hearing will be held on May 5, 1992, at 9:00 a.m. in Room 145 Department of Agriculture Building, 90 West Plato Boulevard, Saint Paul, Minnesota, on a proposal that the Minnesota Rural Finance Authority (the Authority) issue its revenue bond under *Minnesota Statutes*, Chapter 41C, in order to finance the purchase of approximately 82 acres of farmland located in Section 7 McPherson Township, Blue Earth County, Minnesota on behalf of Brad Loeffler, a single person (the Borrowers). The maximum aggregate face amount of the proposed bond issue is \$98,000. The revenue bond will be a limited obligation of the Authority, payable solely from the revenue pledged to the payment thereof. No holder of such revenue bond will ever have the right to compel any exercise of the taxing power of the State of Minnesota to pay the bond or the interest hereon, nor to enforce payment against any property of the Authority or the State of Minnesota, except the revenues specifically pledged to the payment thereof. Before issuing the revenue bond, the Authority will enter into an agreement with the Borrower whereby the Borrower will be obligated to make payments at least sufficient at all times to pay the principal of and interest on such revenue bond when due.

All persons interested may appear and be heard at the time and place set forth above, or may file written comments with the Executive Director of the Authority prior to the date of the hearing set forth above.

Dated: 4 March 1992

LaVonne Nicolai  
RFA Executive Director

### Minnesota Rural Finance Authority

#### Notice of Public Hearing on the Issuance of an Agricultural Development Revenue Bond

**NOTICE IS HEREBY GIVEN** that a public hearing will be held on May 5, 1992, at 9:00 a.m. in Room 145 Department of Agriculture Building, 90 West Plato Boulevard, Saint Paul, Minnesota, on a proposal that the Minnesota Rural Finance Authority (the Authority) issue its revenue bond under *Minnesota Statutes*, Chapter 41C, in order to finance the purchase of approximately 320 acre dairy farm located in Section 24 Township 105N, R 11W, Olmsted County, Minnesota on behalf of Timothy C. & Lorisa J. Heim, a married couple (the Borrowers). The maximum aggregate face amount of the proposed bond issue is \$225,000. The revenue bond will be a limited obligation of the Authority, payable solely from the revenue pledged to the payment thereof. No holder of such revenue bond will ever have the right to compel any exercise of the taxing power of the State of Minnesota to pay the bond or the interest hereon, nor to enforce payment against any property of the Authority or the State of Minnesota, except the revenues specifically pledged to the payment thereof. Before issuing the revenue bond, the Authority will enter into an agreement with the Borrower whereby the Borrower will be obligated to make payments at least sufficient at all times to pay the principal of and interest on such revenue bond when due.

All persons interested may appear and be heard at the time and place set forth above, or may file written comments with the Executive Director of the Authority prior to the date of the hearing set forth above.

Dated: 31 March 1992

LaVonne Nicolai  
RFA Executive Director

### Minnesota Rural Finance Authority

#### Notice of Public Hearing on the Issuance of an Agricultural Development Revenue Bond

**NOTICE IS HEREBY GIVEN** that a public hearing will be held on May 5, 1992, at 9:00 a.m. in Room 145 Department of Agriculture Building, 90 West Plato Boulevard, Saint Paul, Minnesota, on a proposal that the Minnesota Rural Finance Authority (the Authority) issue its revenue bond under *Minnesota Statutes*, Chapter 41C, in order to finance the purchase of an established dairy herd located in Section 15 Mt. Vernon Township, Winona County, Minnesota on behalf of Larry E. Kendrick, a single person (the Borrower). The maximum aggregate face amount of the proposed bond issue is \$50,000. The revenue bond will be a limited obligation of the Authority, payable solely from the revenue pledged to the payment thereof. No holder of such revenue bond will ever have the right to compel any exercise of the taxing power of the State of Minnesota to pay the bond or the interest hereon, nor to enforce payment against any property of the Authority or the State of Minnesota, except the revenues specifically pledged to the payment thereof. Before issuing the revenue bond, the Authority will enter into an agreement with the Borrower whereby the Borrower will be obligated to make payments at least sufficient at all times to pay the principal of and interest on such revenue bond when due.



All persons interested may appear and be heard at the time and place set forth above, or may file written comments with the Executive Director of the Authority prior to the date of the hearing set forth above.

Dated: 1 April 1992

LaVonne Nicolai  
RFA Executive Director

## **Minnesota Rural Finance Authority**

### **Notice of Public Hearing on the Issuance of an Agricultural Development Revenue Bond**

**NOTICE IS HEREBY GIVEN** that a public hearing will be held on May 5, 1992, at 9:00 a.m. in Room 145 Department of Agriculture Building, 90 West Plato Boulevard, Saint Paul, Minnesota, on a proposal that the Minnesota Rural Finance Authority (the Authority) issue its revenue bond under *Minnesota Statutes*, Chapter 41C, in order to finance the purchase of approximately 395 acre dairy farm located in Section 15 Mt. Vernon Township, Winona County, Minnesota on behalf of Larry E. Kendrick, a single person (the Borrower). The maximum aggregate face amount of the proposed bond issue is \$200,000. The revenue bond will be a limited obligation of the Authority, payable solely from the revenue pledged to the payment thereof. No holder of such revenue bond will ever have the right to compel any exercise of the taxing power of the State of Minnesota to pay the bond or the interest hereon, nor to enforce payment against any property of the Authority or the State of Minnesota, except the revenues specifically pledged to the payment thereof. Before issuing the revenue bond, the Authority will enter into an agreement with the Borrower whereby the Borrower will be obligated to make payments at least sufficient at all times to pay the principal of and interest on such revenue bond when due.

All persons interested may appear and be heard at the time and place set forth above, or may file written comments with the Executive Director of the Authority prior to the date of the hearing set forth above.

Dated: 1 April 1992

LaVonne Nicolai  
RFA Executive Director

## **Minnesota Rural Finance Authority**

### **Notice of Public Hearing on the Issuance of an Agricultural Development Revenue Bond**

**NOTICE IS HEREBY GIVEN** that a public hearing will be held on May 5, 1992, at 9:00 a.m. in Room 145 Department of Agriculture Building, 90 West Plato Boulevard, Saint Paul, Minnesota, on a proposal that the Minnesota Rural Finance Authority (the Authority) issue its revenue bond under *Minnesota Statutes*, Chapter 41C, in order to finance the purchase of approximately 146 acres of farmland located in Section 17 Benson Township, Swift County, Minnesota on behalf of Michael J. & Sheila K. Goff and Philip J. & Nancy Goff the Borrowers. The maximum aggregate face amount of the proposed bond issue is \$90,000. The revenue bond will be a limited obligation of the Authority, payable solely from the revenue pledged to the payment thereof. No holder of such revenue bond will ever have the right to compel any exercise of the taxing power of the State of Minnesota to pay the bond or the interest hereon, nor to enforce payment against any property of the Authority or the State of Minnesota, except the revenues specifically pledged to the payment thereof. Before issuing the revenue bond, the Authority will enter into an agreement with the Borrower whereby the Borrower will be obligated to make payments at least sufficient at all times to pay the principal of and interest on such revenue bond when due.

All persons interested may appear and be heard at the time and place set forth above, or may file written comments with the Executive Director of the Authority prior to the date of the hearing set forth above.

Dated: 31 March 1992

LaVonne Nicolai  
RFA Executive Director

## **Minnesota Rural Finance Authority**

### **Notice of Public Hearing on the Issuance of an Agricultural Development Revenue Bond**

**NOTICE IS HEREBY GIVEN** that a public hearing will be held on May 5, 1992, at 9:00 a.m. in Room 145 Department of Agriculture Building, 90 West Plato Boulevard, Saint Paul, Minnesota, on a proposal that the Minnesota Rural Finance Authority (the Authority) issue its revenue bond under *Minnesota Statutes*, Chapter 41C, in order to finance barn improvements located in

## Official Notices

---

Section 26 Graceville Township, Big Stone County, Minnesota on behalf of Jon Pansch, a single person (the Borrower). The maximum aggregate face amount of the proposed bond issue is \$20,000. The revenue bond will be a limited obligation of the Authority, payable solely from the revenue pledged to the payment thereof. No holder of such revenue bond will ever have the right to compel any exercise of the taxing power of the State of Minnesota pay the bond or the interest hereon, nor to enforce payment against any property of the Authority or the State of Minnesota, except the revenues specifically pledged to the payment thereof. Before issuing the revenue bond, the Authority will enter into an agreement with the Borrower whereby the Borrower will be obligated to make payments at least sufficient at all times to pay the principal of and interest on such revenue bond when due.

All persons interested may appear and be heard at the time and place set forth above, or may file written comments with the Executive Director of the Authority prior to the date of the hearing set forth above.

Dated: 1 April 1992

LaVonne Nicolai  
RFA Executive Director

## Office of the Secretary of State

### Notice of Vacancies in Multi-Member Agencies

**NOTICE IS HEREBY GIVEN** to the public that vacancies have occurred in multi-member state agencies, pursuant to *Minnesota Statutes* 15.0597, subdivision 4. Application forms may be obtained from the Office of the Secretary of State, Open Appointments, 180 State Office Building, St. Paul, MN 55155-1299; (612) 297-5845, or in person at Room 174 of the State Office Building. More specific information about these vacancies may be obtained from the agencies listed below. These vacancies will remain open for application through May 12, 1992. Appointing Authorities may also choose to review applications received after that date. Applications are kept on file for a one year period.

#### **SPECIAL EDUCATION ADVISORY COUNCIL**

800 Capitol Square Bldg., 550 Cedar St., St. Paul 55101. 612-297-4682

*Public Law* 94-142

**APPOINTING AUTHORITY:** State Board of Education. **COMPENSATION:** Reimbursed for expenses.

**VACANCY:** Five vacancies for the 1992-95 term. To ensure appropriate representation, special consideration will be given to the following: parents of children with disabilities, representatives of special education teacher training programs, special education directors, and building principals. To maintain geographic balance, consideration will also be given to representatives from Congressional Districts 3 and 6. For further information please contact Elizabeth Watkins at (612) 297-4682.

The council assists the state in developing policies, plans and practices that will assure effective and efficient special education programs for learners with disabilities ages birth to 21. The fifteen member council represents parents of children with disabilities, consumers, advocacy organizations, special education teachers and administrators, regular education teachers and administrators, and higher education teacher training programs, as well as Congressional Districts. Members are appointed for three year terms. The council generally meets five times each school year. Meetings are one and one-half days in length. Reimbursement is provided for travel costs, lodging and meals.

#### **GAMBLING CONTROL BOARD**

1711 W. Co. Rd. B, Roseville 55113. 612-639-4000

*Minnesota Statutes* 349.151

**APPOINTING AUTHORITY:** Governor/Attorney General/Commissioner of Public Safety. **COMPENSATION:** \$55 per diem plus expenses.

**VACANCY:** Two vacancies: to be appointed by the Governor.

The board issues, suspends and revokes licenses of organizations, bingo halls, distributors and manufacturers of gambling equipment, registers gambling equipment, collects license fees and inspects records, conducts hearings to insure integrity of operations and compliance with all applicable laws and rules. The board consists of seven members including five members appointed by the governor, one member appointed by the commissioner of Public Safety, and one member appointed by the attorney general. No more than three members appointed by the governor may belong to the same political party. All appointments are with the advice and consent of the senate. Members must file with the Ethical Practices Board. Meetings are held at the Kelly Inn, St. Paul, on the third Monday of each month.

#### **ETHICAL PRACTICES BOARD**

First Floor South, Centennial Bldg., 658 Cedar St., St. Paul 55155. 612-296-5148

*Minnesota Statutes* 10A.02

**APPOINTING AUTHORITY:** Governor. House and senate confirmation. **COMPENSATION:** \$55 per diem plus expenses.  
**VACANCY:** Two vacancies: One former DFL legislator, and one public member to be the same political party as the governor.

The board administers campaign finance disclosure for state candidates, economic interest disclosure for state, metropolitan public officials, and local officials in metropolitan governmental units, lobbyist registration, and public subsidy of state candidates and political party committees, and financial incentives for congressional candidates. The board consists of six members, including one former state legislator from a major political party different from the governor, one former state legislator from the same political party as the governor, two members who have not been public officials and have not held party office within three years prior to appointment. No more than three members may support the same political party. No member may currently serve as a lobbyist. Monthly meetings in the capitol complex, St. Paul. Members must file with the Ethical Practices Board.

#### **ADVISORY COUNCIL ON UNIFORM FINANCIAL ACCOUNTING AND REPORTING STANDARDS**

Room 559, Capitol Square Bldg., St. Paul 55101. 612-296-8640  
*Minnesota Statutes* 121.901

**APPOINTING AUTHORITY:** Bd. Education/Com. Education/Bd. Tech. Coll./State Auditor. **COMPENSATION:** None.  
**VACANCY:** One vacancy: one of eight persons who are representative of various size school districts in the state and who are public school employees whose position involves activities related to school financing and accounting.

The council provides uniform accounting and reporting standards for school districts and recommends rules, statute changes, modifications of financial accounting codes, manuals, procedures and reporting forms. The council consists of thirteen members including two employees of the Department of Education appointed by the commissioner of education, one licensed certified public accountant appointed by the State Board of Education, eight school district employees whose responsibilities include school financing and accounting appointed by the State Board of Education, one person appointed by the State Board of Technical Colleges, and one member of the state auditor's office appointed by the state auditor. Professional associations composed of persons eligible to be appointed may recommend nominees from their association to the State Board of Education. The council shall annually select a chair and secretary from its membership. Approximately six meetings per year.

---

---

## **State Grants**

In addition to requests by state agencies for technical/professional services (published in the State Contracts section), the *State Register* also publishes notices about grant funds available through any agency or branch of state government. Although some grant programs specifically require printing in a statewide publication such as the *State Register*, there is no requirement for publication in the *State Register* itself.

Agencies are encouraged to publish grant notices, and to provide financial estimates as well as sufficient time for interested parties to respond.

---

## **Department of Corrections**

### **Notice of Availability of Funds for Pilot Programs for the Treatment of Sex Offenders**

The Minnesota Department of Corrections, Community Services Division, announces the availability of grant funds for development of pilot programs for the treatment of sex offenders.

A total of \$64,000 is available for programs to treat adult and juvenile sex offenders who are sentenced by the court to incarceration in a local correctional facility or to sex offender treatment as a condition of probation, and for juveniles found delinquent or receiving a stay of adjudication for whom the juvenile court has ordered sex offender treatment. The funds will be available for approximately 12 months, July, 1992 - June 30, 1993.

This is "one time only" funding. Continuation funding WILL NOT be available.

To be eligible to apply, an applicant organization must be a public human services or community corrections agency. (M.S. 241.67, subd 5) The deadline for grant proposal submission is Friday, May 15, 1992, 4:30 p.m. To receive a request for proposal which describes in detail how to apply for this funding and the requirements of the legislation, contact Ethel Jackman, Minnesota Department of Corrections, Community Services Division, 300 Bigelow Building, 450 North Syndicate, St. Paul, Minnesota, 55104. Telephone (612) 642-0235.

April 1992

## State Grants

---

---

### Department of Human Services

#### CD Program Division

#### Grant Monies Available for American Indian Adolescent Aftercare

The Chemical Dependency Program Division (CDPD) of the Minnesota Department of Human Services is soliciting proposals from non-profit organizations, private organizations, and units of government to provide structured services for American Indian adolescents age 14 through 18 who have completed an inpatient or outpatient chemical dependency treatment program.

The funded program(s) should begin on or about September 1, 1992 and continue for 12 months. A total of \$24,000 is available to fund one or more grantees. Grant funds can be used to enhance current projects or to start a new program. The project(s) may continue beyond the initial year based on satisfactory performance and availability of funds.

The goal of the aftercare project is to reduce the return to the abuse of addictive chemicals by American Indian adolescents ages 14 to 18.

Telephone requests for programmatic information concerning this RFP should be directed to Ron Welch at (612) 296-4043. Budget/fund use questions should be directed to Ms. Dorrie Hennagir at (612) 296-4617.

## Professional, Technical & Consulting Contracts

---

---

Department of Administration procedures require that notice of any consultant services contract or professional and technical services contract which has an estimated cost of over \$10,000 be printed in the *State Register*. These procedures also require that the following information be included in the notice: name of contact person, agency name and address, description of project and tasks, cost estimate, and final submission date of completed contract proposal. Certain quasi-state agencies are exempted from some of the provisions of this statute.

---

### Department of Administration

#### InterTechnologies Group

#### Proposals Sought for Professional Computer Services

The Department of Administration, InterTechnologies Group (InterTech), is requesting proposals for microcomputer analysis, programming and support services to supplement InterTech and agency(s) staffs. These services will be used only on an as-needed basis. InterTech is soliciting these services so that peak workloads and unique skills work can be handled with no loss of service to agencies, without necessitating overstaffing on the part of InterTech and agencies.

A bidder's conference will be held at 9:00 a.m., Friday, April 24, 1992 in the Lady Slipper Room, Ground Floor, Centennial Office Building, 658 Cedar Street, St. Paul.

Copies of the RFP may be requested from:

Paul R. Stembler, Acting Manager  
Applied Computing Technologies  
Products and Services Division  
InterTechnologies Group  
500 Centennial Office Building  
658 Cedar Street  
St. Paul, MN 55155  
(612) 296-0498

or

Bonnie Frey, Analyst  
Applied Computing Technologies  
Products and Services Division  
InterTechnologies Group  
500 Centennial Office Building  
658 Cedar Street  
St. Paul, MN 55155  
(612) 296-7651

### Department of Finance

#### Statewide Systems Project

#### Request for Information on Software Packages for Statewide Systems Supporting Accounting, Human Resources, Payroll and Purchasing

The Minnesota Department of Finance, Statewide Systems Project, is requesting information concerning software packages that

---

---

## Professional, Technical & Consulting Contracts

are capable of supporting the following critical statewide business functions in the State of Minnesota's operating environment: Accounting, Human Resources, Payroll and Purchasing.

The Project Team's purpose in requesting this information is to assist them in the development of the software selection and acquisition process that is expected to take place later this year. The Project Team expects that the information received in response to this Request for Information will assist them in clearly defining system requirements and in designing the selection and acquisition process.

For further information, or to obtain a copy of the complete Request for Information, contact:

Sharon Radman, Project Director  
Statewide Systems Project  
Department of Finance  
400 Centennial Building  
658 Cedar Street  
St. Paul, MN 55155  
Phone: (612) 296-9392

Information will be accepted until 4:30 p.m. on May 8, 1992.

### Department of Human Services

#### Proposals Sought for Chemical Dependency Treatment Outcome Follow-up Interviews

The Chemical Dependency Program Division (CDPD) is requesting proposals from qualified research consultants to conduct posttreatment telephone follow-up interviews with adult chemical dependency clients. The funded follow-up will begin on or about September 1, 1992, and continue through July, 1993. The maximum funding for approximately 300 to 500 follow-up interviews is \$7,500. This follow-up is part of the field testing of the Chemical Dependency Treatment Accountability Plan. Ensuing years of this project will have an annual follow-up budget of approximately \$60,000.

Follow-up interview data will be recorded on-line using software running on an IBM PC-compatible microcomputer. Software with data entry screens and training will be provided by the CDPD.

Telephone requests for information regarding this RFP should be directed to Patricia Harrison at (612) 296-8574.

### Department of Human Services

#### Long Term Care Division

#### Proposals Sought to Analyze Rate Setting Systems for ICFs/MR

The Minnesota Department of Human Services is soliciting proposals from qualified parties to analyze the rate setting systems for nursing homes and Intermediate Care Facilities for Persons with Mental Retardation (ICFs/MR) and their ability to allow delivery of cost effective services meeting state and federal standards. The outcome of this project is to provide recommendations, including specific standards or measures, which the State of Minnesota, Department of Human Services can apply to its present rate setting system and can utilize when making future policy decisions having fiscal impact. These standards should offer an objective benchmark by which to measure the impact of present and future policy decisions to assure that compliance with Federal standards for medicaid reimbursement are maintained.

This Request for Proposals does not obligate the State to complete the project, and the State reserves the right to cancel the solicitation if it is considered to be in its best interest.

The Department has estimated that the cost of this contract will not exceed \$50,000.00. All proposals must be submitted no later than May 29, 1992.

For a copy of a more detailed explanation of this request for proposals, please contact:

Sue Banken  
Department of Human Services  
Division of Long Term Management  
444 Lafayette Rd.  
St. Paul, MN 55155-3844  
(612) 296-5724

## Professional, Technical & Consulting Contracts

---

---

### Department of Human Services

#### Long Term Care Division

#### Proposals Sought for an Independent Assessment of the Community Alternatives for Independent Living Waiver Program

This is a request for proposals for an independent assessment of Minnesota's Title XIX home and community based waiver as required by federal regulations (42 CFR 441.304(g)).

The purpose of this project is to objectively evaluate, according to the Health Care Financing Administration's (HCFA) criteria, the quality of care provided, access to care, and cost effectiveness of one of Minnesota's home and community based waiver programs. As part of this process, the Department also wants to receive recommendations for program improvement especially in the areas of quality of care, access to care, and cost effectiveness. The project must evaluate at least the first 48 months of the CADI program which would include the time period from October 1, 1990 through September 30, 1994.

All proposals for this request must be postmarked on or before June 1, 1992. Selection of the proposal will be completed by July 15, 1992.

Prospective respondents who have questions regarding this request may call or write:

Lynn Glockner  
Minnesota Department of Human Services  
444 Lafayette Road  
St. Paul, Minnesota 55155-3844  
(612) 297-4669

### Department of Human Services

#### Fergus Falls Regional Treatment Center

#### Request for Proposals for Services of a Psychiatrist

**NOTICE IS HEREBY GIVEN** that the Fergus Falls Regional Treatment Center, Department of Human Services, is seeking the following services which are to be performed as requested by the Administration of the Fergus Falls Regional Treatment Center. Contracts will be written for the period of July 1, 1992 through June 30, 1993.

Services of one or more locum tenens board eligible psychiatrists for a total of one Full Time Equivalent at the Fergus Falls Regional Treatment Center for diagnosis and treatment of emotional disorders of mentally ill, chemically dependent and mentally retarded clients. The total estimated amount of the contracts will not exceed \$80,000.

Further information on position responsibilities may be obtained by contacting Leonard Woytassek, M.D., Medical Director, Fergus Falls Regional Treatment Center, PO Box 157, Fergus Falls, MN 56538-0157. (218) 739-7200.

### Minnesota State Lottery

#### Bids Sought for Printed T-shirts

The Minnesota State Lottery will be seeking bids for 10,000 printed T-Shirts. Bid deadline is April 17, 1992 at 9:00 a.m. Bids arriving after that time will not be accepted. Delivery will be needed by May 1, 1992. Approximate cost is \$30,000.00. This purchase will be made under provision of MS 349A.07 which states in part:

"The director shall utilize an open bid process and shall take into account the particularly sensitive nature of the state lottery and shall consider the competence, quality of product, experience, and timely performance of each potential vendor in order to promote and ensure security, honesty, fairness, and integrity in the operation and administration of the lottery."

Companies interested in bidding should contact:

|                         |                     |
|-------------------------|---------------------|
| Susie Kivi              | Roseville, MN 55113 |
| Minnesota State Lottery | (612) 635-8105      |
| 2645 Long Lake Road     | FAX (612) 297-7497  |

## Minnesota Pollution Control Agency

### Water Quality Division

#### Request for Proposals for Toxicity Tests of Storm Water Entering Miller Creek, Duluth, Minnesota

The Minnesota Pollution Control Agency (MPCA), Water Quality Division, is seeking proposals from qualified laboratories to perform toxicity tests on selected storm waters entering Miller Creek from approximately May 15, 1992, to June 30, 1993 (end date may be extended to September 30, 1993, if the summer of 1992 is extremely dry).

#### A. PURPOSE OF THE PROJECT

The purpose of this project is to prioritize storm water from various land use types for permitting under the National Pollution Discharge Elimination System (NPDES), using the results of standard toxicity testing methods as a basis. Five sites representing different land uses will be tested on four separate occasions. Three storm events and one spring snow-melt will be tested.

#### B. TOXICITY TESTING METHODS

Testing methods must follow those promulgated by the U.S. Environmental Protection Agency in "Methods for Measuring the Acute Toxicity of Effluents to Freshwater and Marine Organisms" EPA-600/4-85/013 March 1985, and "Short Term Methods for Estimating the Chronic Toxicity of Effluents and Receiving Waters to Freshwater Organisms" EPA/600/4-89/001 Second Edition and "Methods for Aquatic Toxicity Identification Evaluations—Phase 1 Toxicity Characterization Procedures" EPA/600/6-91/003 Second Edition.

Test Species—Fathead minnows (Pimephales Promelas Rafinesque), and Ceriodaphnia dubia.

#### C. WATER CHEMISTRY

The proposer must be able to measure the following parameters at the corresponding detection limits in water samples:

| Parameter           | Detection Limit (ug/l) | Parameter              | Detection Limit (mg/l) |
|---------------------|------------------------|------------------------|------------------------|
| Arsenic             | 1                      | Chloride               | 1                      |
| Cadmium             | 0.1                    | Total Dissolved Solids | 10                     |
| Chromium            | 2                      | Total Suspended Solids | 5                      |
| Hexavalent Chromium | 2                      | Kjeldahl Nitrogen      | .05                    |
| Copper              | 1                      | Nitrogen, Ammonia      | .05                    |
| Lead                | 1                      | Nitrate                | .01                    |
| Nickel              | 1                      | Ortho Phosphorus       | .002                   |
| Zinc                | 5                      | Total Phosphorus       | .002                   |
| Phenols             | 10                     | Sulfate                | 1                      |
|                     |                        | Oil and Grease         | 1                      |

Methods must meet or exceed in quality those established in "Standard Methods for the Examination of Water and Wastewater" 17th Edition.

#### D. QUALITY ASSURANCE (QA)

The proposer must be capable of meeting the quality control acceptance criteria as they pertain to the methods cited in parts B and C. The state does not approve and no payment shall be made for work that does not meet professional standards or that has not been performed in accordance with all applicable federal and state laws, rules and regulations, and the terms of the contract.

#### E. REPORTING RESULTS

The proposer must verbally communicate results of toxicity tests within 48 hours of test completion.

Written results will be provided within two weeks of test completion, including test measurements, mortality data, behavioral observations, lethal concentration (LC50) and/or effect concentration calculations from test mortality/growth, reproduction data, reference toxicity data for each species, and/or test organism culture performance indicators.

#### F. PROPOSAL CONTENTS

These instructions describe the minimum information needed for the required contract of the proposer to help insure a timely evaluation of all bids submitted for review. Proposals must include:

## Professional, Technical & Consulting Contracts

---

---

1. A cost estimate for 20 acute tests (10 fathead, 10 ceriodaphnia).
2. A cost estimate for 40 acute tests (20 fathead, 20 ceriodaphnia).
3. A cost estimate for analysis of 20 water samples for the parameters listed in Part C.
4. Experience and qualifications of laboratory personnel.
5. Laboratory Standard Operating Procedures for conducting aquatic toxicity tests, and water chemistry analyses listed in part C.
6. Prices for 7 day chronic tests—for each species.
7. Prices for 4 day chronic test—ceriodaphnia.
8. Prices for Phase 1 Acute Toxicity Characterization Procedures—each species.
9. Prices for water chemistry analyses listed in part C.

If prices per test vary depending upon the number of tests performed at any one time, a schedule of prices for a given number of tests of the same kind should be included in the proposal. All work shall be performed in accordance with the QA Program. The vendor may include any other information deemed pertinent.

### G. AWARD

The result of initial acute tests will be used to determine the types and numbers of tests to follow. These may include acute tests, chronic tests, or an Acute Phase 1 Identification Procedure. The exact type and number of tests to be conducted can not be predicted prior to the initiation of the study, therefore the contract will be awarded on the following criteria.

1. The cost estimate on the 20 and 40 acute tests.
2. The cost estimate on the 20 samples analyzed for the parameters listed in part C.
3. Prices submitted for Phase 1 Toxicity Characterization Procedures.
4. Prices submitted for 7 day chronic tests—both species.
5. Prices submitted for 4 day ceriodaphnia chronic test.
6. Laboratory experience and qualifications.
7. An evaluation of the information submitted with the bid.

All proposals must be directed to the following and received no later than 5:00 p.m., May 15, 1992:

Marvin Hora  
Assessment and Planning  
Water Quality Division  
Minnesota Pollution Control Agency  
520 Lafayette Road  
St. Paul, MN 55155 Telephone: (612) 296-7215.

Late proposals will not be accepted. Please submit four copies of the proposal with each signed, in ink, by an authorized member of the firm. Prices and terms of the project as stated must be valid for the length of the project.

## Pollution Control Agency

### Hazardous Waste Division

### Request for Proposal to Develop a Public Awareness Campaign in the Lake Superior Basin

The Minnesota Pollution Control Agency (MPCA), Hazardous Waste Division is requesting proposals from qualified individuals or firms interested in developing and implementing a public information campaign on hazardous waste issues. The area served will be the Minnesota portion of the Lake Superior Basin, which includes Duluth, the North Shore to the Canadian border, and parts of the Iron Range. The cost of the proposal must not exceed \$30,500.

Proposals must be received no later than 2:00 p.m., May 15, 1992.

Pre-proposal informational meetings will be held:

Wednesday, April 22, at 10:00 a.m. in Conference Room 1 on the fourth floor, MPCA Central Office, 520 Lafayette Road North, St. Paul, Minnesota.



---

---

## Professional, Technical & Consulting Contracts

Thursday, April 23, at 9:00 a.m. at the MPCA Duluth Office, 320 West 2nd Street, Government Services Center, Suite 704, Duluth, Minnesota.

For a copy of the Request For Proposals, contact:

Carol Langer  
Minnesota Pollution Control Agency  
320 W. 2nd St., Suite 704  
Duluth, Minnesota 55803  
218-723-4898

### Department of Revenue

#### Professional Services Sought

The Minnesota Department of Administration, Materials Management Division is requesting proposals for contracting services to supplement Dept. of Revenue (DOR) and the Revenue Information Systems Division (RISD) staff. Services requested include business reengineering, systems analysis, programming, documentation, and micro-computer and network support. These contract services are to be provided to the DOR for the period of July 1, 1992, through June 30, 1993. The DOR has estimated the cost of these services to be five million dollars (\$5,000,000.00).

Anyone interested in receiving a copy of this Request for Proposal should contact:

Donald H. Olson  
Contract Administrator  
Materials Management Division  
Rm. 112 State Administration Bldg.  
St. Paul, MN 55155  
FAX No.: 612-297-3996

Request for Proposal Opening Date & Time: May 5, 1992, 3:00 p.m.

### Department of Trade and Economic Development

#### Professional Development Training Services Sought

The State of Minnesota Department of Trade and Economic Development (Department) is seeking proposals from qualified firms and individuals to conduct an Introductory Marketing Concepts and Practices professional development training program for directors and staff of the Minnesota Small Business Development Centers. This request for Proposals (RFP) replaces the Request for Proposals for four-marketing-related training programs published in the *State Register* February 10, 1992. The Department has rejected all proposals submitted in response to that solicitation.

#### Introduction

In its role of providing professional development training to directors and staff of the Minnesota Small Business Development Centers, the Department is seeking proposals from qualified firms and individuals to conduct the work described in this RFP. The contractor will be expected to conduct the training program on or about July 20, 1992.

This RFP does not obligate the Department to enter into a contract for the training program, and the Department reserves the right to cancel this RFP if it is considered to be in the best interest of the Department or the State of Minnesota.

The quality of the proposed training, the qualifications and capability of the contractor to perform the work, and price will be factors in the selection of a contractor.

The Department anticipates the cost of this contract will not exceed \$10,000.

#### Scope of Work

The contractor will be required to develop an intensive program on Introductory Marketing Concepts and Practices that includes at least the following elements:

1. Develop for attendees the following teaching materials for each module: a textbook, which focuses on application rather than traditional theory; a casebook, which would include five cases for homework assignments, and ten cases to be used during lectures; handouts and overheads, and a final examination.

## Professional, Technical & Consulting Contracts

---

---

2. Provide at a Twin Cities site to be identified by the Department a minimum of 33.5 classroom (contact) hours and follow the proposed schedule:

|           |   |
|-----------|---|
| Monday    | 8:30 a.m. - 12:30 p.m.; 1:30 p.m. - 5:00 p.m. |
| Tuesday   | 8:30 a.m. - 12:30 p.m.; 1:30 p.m. - 5:00 p.m. |
| Wednesday | 8:30 a.m. - 12:30 p.m.; 1:30 p.m. - 3:00 p.m. |
| Thursday  | 8:30 a.m. - 12:30 p.m.; 1:30 p.m. - 5:00 p.m. |
| Friday    | 8:30 a.m. - 12:30 p.m.; 1:30 p.m. - 3:00 p.m. |

The classroom time for each module will be allocated among the following activities:

- Lectures—21 hours
- Case Analysis—10.5 hours
- Final Examination—2 hours

3. Provide tutoring during non-classroom time.

### Proposal Format

Proposals submitted in response to this RFP must include all of the following:

1. A description of the proposing firm or individual proposer describing in detail its qualifications and capability to conduct the project. Proposers whose background includes current or previous work in the development and instruction of marketing-related training programs should describe that work in detail, provide samples of past work and identify the clients from whom it was performed. This section of the proposal also must include résumés of all personnel who will work on the project.
2. A detailed budget for the entire project showing a breakdown of expenses for the Scope of Work. The Department reserves the right to award a contract for all or part of the proposed work, and any award for part of the work will be based on the proposed budget.

The budget must identify each professional staff person assigned to the project, describe the work each will perform, and state the hourly rate to be paid to each.

Reimbursement for out-of-pocket expenses incurred by the contractor shall not exceed that provided in the current "Commissioner's Plan" promulgated by the Commissioner of Employee Relations. Some of the more common of these expenses, and the maximum reimbursement are:

Meals:

- Breakfast, \$7, payable if the individual is in travel status before 6:00 a.m. or is away from home overnight;
- Lunch, \$8.50, payable if the individual is in travel status more than 35 miles from home or is away from home overnight;
- Dinner, \$14.50, payable if the individual cannot return home until after 7:00 p.m. or is away from home overnight.

Mileage:

\$ .27 per mile.

Lodging:

Actual reasonable cost. (Receipts Required)

The contractor shall not be reimbursed for travel or other expenses incurred outside the State of Minnesota unless it secures prior written approval of the Department.

Printing of training materials will be done by the Department. The contractor shall submit one camera-ready copy of all training materials to the Department in sufficient time for those materials to be duplicated by the Department. Proposers should not include printing costs as part of their budget.

The use and identity of subcontractors for any part of the project must be specifically approved in advance by the Department.

In developing the budget, proposers are directed to the section of this RFP titled "Special Clauses Anticipated in Any Contract Awarded" for information on other elements of the proposed contract that may affect the nature, timing, and cost of performance.

3. Samples of a course outline and two cases for one module.

4. A detailed work plan including a timetable for completion of the Scope of Work.

### Project Start and End Dates

The training program is expected to begin on or about July 20, 1992. The actual start date will be negotiated with the contractor.

### Evaluation of Proposal

All proposals received by the submission deadline will be evaluated by the Department. The Department may seek, but is not

---

---

## Professional, Technical & Consulting Contracts

obligated to seek, assistance in evaluating proposals from other state agencies, members of the Minnesota Small Business Development Centers, and parties outside state government.

The most important factors in the evaluation of proposals will be:

1. The qualifications of the proposer and personnel to be associated with the project;
2. The evaluators' judgement of the proposer's capacity to perform the work; and
3. The reasonableness of the budget in accomplishing the Scope of Work.

Proposals will be evaluated on the basis of materials submitted by the proposer, exclusive of any third party recommendations or testimonials. Proposers are discouraged from attaching such materials to their proposals.

### Department Contact

Proposers who have questions regarding this RFP should contact: Randall D. Olson, State Director, Minnesota Small Business Development Centers, Minnesota Department of Trade and Economic Development, 900 American Center Building, 150 East Kellogg Boulevard, St. Paul, MN 55101, telephone (612) 297-5770. Mr. Olson is the only employee authorized to answer questions regarding this RFP.

### Submission of Proposals

To be considered, proposals must be sent to and received by: Randall D. Olson, State Director, Minnesota Small Business Development Centers, Minnesota Department of Trade and Economic Development, 900 American Center Building, 150 East Kellogg Boulevard, St. Paul, MN 55101, no later than 4:30 p.m., May 15, 1992.

Late proposals will not be accepted.

Proposers must submit six (6) copies of the proposal.

Proposers must secure each copy of the proposal with a single staple in the upper left corner, or use other easily-removable binding to facilitate photocopying. Do not use GBC-type or other permanent binding.

Proposals must be sealed in mailing envelopes or packages with the proposer's name and address clearly written on the outside. Each copy of the proposal must be signed with an original signature, in ink, by the individual submitting the proposal or by an authorized member of the firm. By signing the proposal, the proposer certifies that prices and terms quoted in the proposal will be as stated for the duration of the project.

Telephonic, telegraphic, or facsimile machine transmitted proposals will not be accepted.

### Special Clauses Anticipated in Any Contract Awarded

Prospective proposers should take note of the following special clauses which the Department anticipates will be a part of any contract awarded. These clauses may affect the nature, timing and cost of performance. Any contract resulting from this RFP also will include standard clauses required by state law.

#### 1. Allowable Costs

Funds awarded by contract shall be used only to reimburse direct expenses actually incurred in performing the Scope of Work. Specifically unallowable are indirect or overhead costs, contractor's profit, costs of production and submission of more than three copies of any report, and reimbursement of expenses which exceed allowable reimbursements under the current Commissioner's Plan issued by the Department of Employee Relations. Where proposals contain items of proposer cost usually included in indirect costs (e.g., telephone service, copying charges, support staff salaries), these items should be reflected as direct charges in the proposal budget.

#### 2. Level of Effort and Standard of Work

Unless otherwise agreed in advance by the Department in writing, the contractor, or its employees shall personally perform the work described in this RFP and the contractor's proposal. The contractor shall apply its best efforts to the work and shall ensure that any work performed by others is performed by persons with appropriate skills and expertise.

#### 3. Subcontracting

The contractor's services shall not be subcontracted to any other person, assigned or transferred without the prior written authorization of the Department.

#### 4. Use of Department Facilities and Personnel

Except as explicitly authorized by the Department through its Agreement Representative, all work, other than the delivery of the training session, shall be performed at the contractor's facilities, using the contractor's equipment and the contractor's personnel. Contractors who are employed by or perform services under contract to any state agency, department or educational institution shall not utilize the facilities, personnel, or other resources of that state entity in performing the contract.

## Professional, Technical & Consulting Contracts

---

---

### 5. Certification

Before entering into any contract, the Department will require from the contractor evidence of compliance with *Minnesota Statutes* 290.97 dealing with the payment of withholding taxes to the State of Minnesota, and *Minnesota Statutes* 176.182 dealing with workers' compensation insurance.

### 6. Ownership of Documents

Any training materials or books (including notes and drafts) and any reports, studies, photographs, negatives, or other documents prepared by the contractor in performing the contract shall be the exclusive property of the Department and shall be remitted to the Department upon completion of the contract. The contractor shall not use, willingly allow or cause to have such materials used for any purpose other than performance of the contractor's obligations under the contract without the prior written consent of the Department.

The contractor shall not copyright in its own name any materials produced in connection with the contract. The state and the Department reserve the right to copyright any or all of these products in their own name.

The Department retains the right to edit, revise, enlarge, reduce, add to, or delete from materials submitted by the contractor.

## Department of Transportation

### Notice of Request for Proposals for Succession Planning

The Minnesota Department of Transportation is accepting proposals from qualified consultants or firms experienced in the development, marketing and implementation of a comprehensive Succession Planning System.

The major responsibilities of the consultant/firm are:

1. To work with Department executive management in operationally defining the concept of Succession Planning.
2. To work with the Department of Transportation Office of Human Resources in identifying existing Human Resource programs that could be integrated into the overall Succession Plan.
3. To work with the Office of Human Resources in developing a practical plan for orienting the Commissioner and his staff to the general concept of Succession Planning and deciding the specific needs of the Department.
4. To work with the Office of Human Resources in developing policies addressing Succession Planning.
5. To work with the Office of Human Resources in identifying positions that will be integrated into the Succession Planning System.
6. To work with the Office of Human Resources in conducting a formal Organizational Needs Analysis on those positions that will be a part of the Succession Plan.
7. To work with the Office of Human Resources on conducting formal job evaluations on the identified positions.
8. To work with the Office of Human Resources in determining automated system needs and developing the appropriate configurations and documents.
9. To work with the Office of Human Resources in establishing a process that will address the developmental needs of those employees who will be participating in the Succession Plan.
10. To work with the Office of Human Resources in developing a process that will provide competency profiles.

A contract for the requested services will commence June 1, 1992 and terminate on June 1, 1993. The compensation limit for time and expenses during the contract period is \$20,000.00. The method of payment for the contract is lump-sum, payable at the end of the contract period.

Qualified consultants/firms should submit a proposal that focuses on the following areas:

1. Degree of experience in the number of Succession Plans developed.
2. Nature of experience in Succession Plan Development (please list companies/organizations that were previous clients and whether they were private or public).
3. Scope of Succession Plan Development (please indicate the number of positions that were affected within the client organization/firm by the Succession Plan).
4. Consultant Credentials (please list the number of years of practical work experience and academic background of your staff relative to Succession Planning/Human Resource Strategic Planning).

Proposals should be received by 4:30 p.m., Monday, May 4, 1992 addressed to:

Wayne Brede  
Office of Human Resources  
Minnesota Department of Transportation  
515 Transportation Building  
St. Paul, MN 55155

Dated: 3 April 1992

James N. Denn  
Commissioner

## Board of Water and Soil Resources

### Sinkhole Treatment Project Design Consultant Services Sought—Notice to Licensed Civil Engineers

The Minnesota Board of Water and Soil Resources (BWSR) anticipates retaining engineering consultants to assist in the selection and design of sinkhole treatment projects in southeastern Minnesota. This area encompasses nine counties from the Metro area to the Iowa border, where the majority of sinkholes in Minnesota are located.

The BWSR is responsible for administration of the Erosion and Sediment Control and Water Quality Program, providing cost sharing for qualifying projects under *Minnesota Statutes* Section 103C.501. Through a \$250,000 Legislative Commission on Minnesota's Resources grant, additional program funds were made available to participating soil and water conservation districts (SWCDs) to treat selected sinkholes for the purpose of protecting water quality. Up to \$25,000 may be used by the BWSR to provide consulting technical services to SWCDs that prepare sinkhole treatment projects.

Consulting services sought range from assessing various sinkhole treatment projects proposed for installation, to project design and oversight of construction of practices to be installed that are outside the scope of the existing USDA-SCS Field Office Technical Guide.

Qualified firms desiring to be considered as design consultants may request the complete RFP by contacting Chuck Niska at Suite 104, 155 South Wabasha Street, St. Paul, MN 55107, telephone 612-296-3767.

---

---

## Non-State Public Contracts

The *State Register* also serves as a central marketplace for contracts let out on bid by the public sector. The *Register* meets state and federal guidelines for statewide circulation of public notices. Any tax-supported institution or government jurisdiction may advertise contracts and requests for proposals from the private sector.

It is recommended that contracts and RFPs include the following: 1) name of contact person; 2) institution name, address, and telephone number; 3) brief description of project and tasks; 4) cost estimate; and 5) final submission date of completed contract proposal. Allow at least three weeks from publication date (four weeks from date article is submitted for publication). Surveys show that subscribers are interested in hearing about contracts for estimates as low as \$1,000. Contact the editor for further details.

---

## Minnesota Historical Society

### Notice of Request for Proposals for Restoration Services for a Bronze Statue

The Minnesota Historical Society is seeking proposals from qualified firms and individuals to provide conservation and restoration services for a bronze statue located on the State Capitol grounds.

The Request for Proposals is available by calling or writing Gary W. Goldsmith, Contracting Officer, Minnesota Historical Society, 345 Kellogg Blvd. West, St. Paul, MN 55102. Telephone (612) 297-5863.

Proposals must be received not later than 2:00 p.m. May 4, 1992.

Details concerning submission requirements are included in the Request for Proposals.

## Non-State Public Contracts

---

---

### Minnesota Historical Society

#### Notice of Request for Bids for Page Printing Services

The Minnesota Historical Society is seeking bids from qualified firms and individuals to provide services for the production of 1000 sets of printed pages for the loose leaf publication Northern Lights Teacher's Edition.

The Request for Bids is available by calling or writing Gary W. Goldsmith, Contracting Officer, Minnesota Historical Society, 345 Kellogg Blvd. West, St. Paul, MN 55102. Telephone (612) 297-5863.

Bids must be received not later than 2:00 p.m., May 18, 1992.

Details concerning submission requirements are included in the Request for Bids.

### Minnesota Historical Society

#### Notice of Request for Bids for Provision of Store Fixtures

The Minnesota Historical Society is seeking bids from qualified firms and individuals to provide store fixtures for use in the museum stores at the Minnesota History Center.

The Request for Bids is available by calling or writing Gary W. Goldsmith, Contracting Officer, Minnesota Historical Society, 345 Kellogg Blvd. West, St. Paul, MN 55102. Telephone (612) 297-5863.

Bids must be received not later than 2:00 p.m., April 27, 1992.

Details concerning submission requirements are included in the Request for Bids.

### Minnesota Historical Society

#### Notice of Request for Bids for General Construction for Museum Stores

The Minnesota Historical Society is seeking bids from qualified firms and individuals to provide general construction services for the completion of museum stores at the Minnesota History Center.

The Request for Bids is available by calling or writing Gary W. Goldsmith, Contracting Officer, Minnesota Historical Society, 345 Kellogg Blvd. West, St. Paul, MN 55102. Telephone (612) 297-5863.

Bids must be received not later than 2:00 p.m., April 27, 1992.

Details concerning submission requirements are included in the Request for Bids.

### Minnesota Historical Society

#### Notice of Request for Proposals for Fund Accounting Computer Software

The Minnesota Historical Society is seeking proposals from qualified firms and individuals to provide PC network based fund accounting service for its Finance and Administration Division.

The Request for Proposals is available by calling or writing Gary W. Goldsmith, Contracting Officer, Minnesota Historical Society, 345 Kellogg Blvd. West, St. Paul, MN 55102. Telephone (612) 297-5863.

Proposals must be received not later than 2:00 p.m., April 27, 1992.

Details concerning submission requirements are included in the Request for Proposals.

### Minnesota Historical Society

#### Notice of Request for Proposals for Provision of Computer Hardware

The Minnesota Historical Society is seeking proposals from qualified firms and individuals to provide IBM PC compatible computer hardware and peripherals under contract for the next year.

The Request for Proposals is available by calling or writing Gary W. Goldsmith, Contracting Officer, Minnesota Historical Society, 345 Kellogg Blvd. West, St. Paul, MN 55102. Telephone (612) 297-5863.

Proposals must be received not later than 2:00 p.m., April 27, 1992.

Details concerning submission requirements are included in the Request for Proposals.

## **Minnesota Historical Society**

### **Notice of Request for Bids for Manufacture of a Book**

The Minnesota Historical Society is seeking bids from qualified firms and individuals to provide all printing and other services for the manufacture of the book Minnesota in a Century of Change from standing negatives.

The Request for Bids is available by calling or writing Gary W. Goldsmith, Contracting Officer, Minnesota Historical Society, 345 Kellogg Blvd. West, St. Paul, MN 55102. Telephone (612) 297-5863.

Bids must be received not later than 2:00 p.m., May 4, 1992.

Details concerning submission requirements are included in the Request for Bids.

## **Lower Minnesota River Watershed District**

### **Request for Interest Proposals for Legal Consultant Services**

Pursuant to MSA 103B.227, Subd. 5, the Lower Minnesota River Watershed District hereby solicits interest proposals for legal consultant services for two years or less commencing in mid-1992.

Individuals interested in performing legal consultant services for the Lower Minnesota River Watershed District should send a written request to Mr. Larry Samstad, 327 Marschall Road, #200, Shakopee, MN 55379 to receive a proposal. The District's budget for legal services in 1992 is \$24,000.

The Commission will review said proposals and reserves to itself the right to take such action as it deems in the best interest of the Watershed District. All proposals shall be submitted on or before May 25, 1992.

## **Metropolitan Waste Control Commission**

### **Request for Proposals for Professional Services for an Employee Assistance Program**

The Metropolitan Waste Control Commission (MWCC) is requesting proposals for an Employee Assistance Program (EAP) provider for the year July 1, 1992 - June 30, 1993. This Request provides background information on the MWCC and describes items which should be specifically addressed in proposals responding to this RFP.

Additional copies of this request can be obtained by contacting Yvonne Sykes, Mears Park Centre, 230 East 5th Street, St. Paul, MN 55101, 229-2015.

Proposals will be accepted by the Metropolitan Waste Control Commission until 4:30 p.m. on May 15, 1992.

Ten (10) copies of your proposal shall be addressed to:

Metropolitan Waste Control Commission  
Attn: Peter Fleming  
Mears Park Centre  
230 E. 5th Street  
St. Paul, MN 55101

The Metropolitan Waste Control Commission reserves the right to reject all or any proposals, and to waive any minor irregularities and deviations from the requirements outlined in the RFP.

BY ORDER OF THE METROPOLITAN WASTE CONTROL COMMISSION  
Gordon O. Voss, Chief Administrator

# State Contracts and Advertised Bids

Pursuant to the provisions of Minn. Stat. § 14.10, an agency must make reasonable effort to publicize the availability of any services contract or professional and technical services contract which has an estimated cost of over \$2,000.

Commodities contracts with an estimated value of \$15,000 or more are listed under the Materials Management Division, Department of Administration. All bids are open for 7-10 days before bidding deadline. For bid specifics, time lines, and other general information, contact the appropriate buyers whose initials appear in parentheses next to the commodity for bid, by calling (612) 296-6152.

Awards of contracts and advertised bids for commodities and printing, as well as awards of professional, technical and consulting contracts, appear in the midweek STATE REGISTER Contracts Supplement, published every Thursday. Call (612) 296-0931 for subscription information.

## Materials Management Division—Department of Administration:

### Contracts and Requisitions Open for Bid

Call 296-2600 for information on a specific bid, or to request a specific bid.

#### COMMODITY CODE KEY

|   |  |  |
|---|--|--|
| <b>A = Sealed Bid</b>                                 | <b>G = \$5,000-\$15,000<br/>Estimated Dollar Value</b>                           | <b>J = Targeted Vendors Only</b>             |
| <b>B = Write for Price</b>                            | <b>H = \$15,000-\$50,000 Sealed<br/>Bid</b>                                      | <b>K = Local Service Needed</b>              |
| <b>C = Request for Proposal</b>                       | <b>I = \$50,000 and Over Sealed<br/>Bid/Human Rights<br/>Compliance Required</b> | <b>L = No Substitute</b>                     |
| <b>D = Request for Information</b>                    |  | <b>M = Installation Needed</b>               |
| <b>E = \$0-\$1,500 Estimated<br/>Dollar Value</b>     |  | <b>N = Pre-Bid Conference</b>                |
| <b>F = \$1,500-\$5,000 Estimated<br/>Dollar Value</b> |  | <b>O = Insurance or<br/>Bonding Required</b> |

**Commodity:** Gasoline and diesel fuel  
(transport & tankwagon deliveries)  
(rebid)  
**Contact:** Dale Meyer 612-296-3773  
**Bid due date at 2pm:** April 23  
**Agency:** Various  
**Deliver to:** Various  
**Requisition #:** Price contract

**Commodity:** Cleaning supplies  
**Contact:** Norma Cameron 612-296-2546  
**Bid due date at 2pm:** May 12  
**Agency:** Various  
**Deliver to:** Various  
**Requisition #:** Price contract

**Commodity:** Tires—retread type  
**Contact:** Dale Meyer 612-296-3773  
**Bid due date at 2pm:** May 4  
**Agency:** Various  
**Deliver to:** Various  
**Requisition #:** Price contract

**Commodity:** B F—Computer upgrades  
**Contact:** Bernadette Vogel 612-296-3778  
**Bid due date at 4:30pm:** April 24  
**Agency:** Minnesota Department of Health  
**Deliver to:** Minneapolis  
**Requisition #:** B 12200-86783

**Commodity:** B F—486 DX  
**Contact:** Bernadette Vogel 612-296-3778  
**Bid due date at 4:30pm:** April 22  
**Agency:** Bemidji State University  
**Deliver to:** Bemidji  
**Requisition #:** B 26070-14701

**Commodity:** B F—Exercise equipment  
**Contact:** Linda Parkos 612-296-3725  
**Bid due date at 4:30pm:** April 21  
**Agency:** Southwest State University  
**Deliver to:** Marshall  
**Requisition #:** B 26175-02310

**Commodity:** B F—Paper shredder  
**Contact:** Jack Bauer 612-296-2621  
**Bid due date at 4:30pm:** April 24  
**Agency:** Minnesota Department of Health  
**Deliver to:** Minneapolis  
**Requisition #:** B 12400-86887

**Commodity:** A H K L M—Lektriever  
**Contact:** Jack Bauer 612-296-2621  
**Bid due date at 2pm:** April 21  
**Agency:** Minnesota Pollution Control Agency  
**Deliver to:** St. Paul  
**Requisition #:** B 32300-31278

**Commodity:** B F M—Fire alarm system  
**Contact:** Jack Bauer 612-296-2621  
**Bid due date at 4:30pm:** April 24  
**Agency:** Minnesota Correctional Facility  
**Deliver to:** Red Wing  
**Requisition #:** B 78760-03103



---

---

## State Contracts and Advertised Bids

**Commodity:** A H-386/33 Computers  
**Contact:** Bernadette Vogel 612-296-3778  
**Bid due date at 2pm:** April 24  
**Agency:** Minnesota Department of Jobs & Training  
**Deliver to:** St. Paul  
**Requisition #:** B 21200-42616

**Commodity:** B F—Custom wrestling mat  
**Contact:** Linda Parkos 612-296-3725  
**Bid due date at 4:30pm:** April 21  
**Agency:** Mankato State University  
**Deliver to:** Mankato  
**Requisition #:** B 26071-05618

**Commodity:** B F—Exercise equipment  
**Contact:** Linda Parkos 612-296-3725  
**Bid due date at 4:30pm:** April 21  
**Agency:** Rainy River Community College  
**Deliver to:** International Falls  
**Requisition #:** B 27155-55192

**Commodity:** B F—Numbering machine  
**Contact:** Jack Bauer 612-296-2621  
**Bid due date at 4:30pm:** April 24  
**Agency:** Minnesota Department of Health  
**Deliver to:** Minneapolis  
**Requisition #:** B 12400-86888

**Commodity:** B G K M—Silk screen exposure unit  
**Contact:** Jack Bauer 612-296-2621  
**Bid due date at 4:30pm:** April 24  
**Agency:** Minnesota Correctional Facility  
**Deliver to:** Lino lakes  
**Requisition #:** B 78550-08480

**Commodity:** A H—Zymark extraction workstation  
**Contact:** Bernadette Vogel 612-296-3778  
**Bid due date at 2pm:** April 27  
**Agency:** Department of Public Safety  
**Deliver to:** St. Paul  
**Requisition #:** B 07300-34028

**Commodity:** B F—Hard drive for NCR tower  
**Contact:** Bernadette Vogel 612-296-3778  
**Bid due date at 4:30pm:** April 23  
**Agency:** Minnesota Department of Human Rights  
**Deliver to:** St. Paul  
**Requisition #:** B 17000-05021

**Commodity:** B F—486/33 computer  
**Contact:** Bernadette Vogel 612-296-3778  
**Bid due date at 4:30pm:** April 23  
**Agency:** Vermilion Community College  
**Deliver to:** Ely  
**Requisition #:** B 27147-47443

**Commodity:** B F L—Used medical lab equipment  
**Contact:** Bernadette Vogel 612-296-3778  
**Bid due date at 4:30pm:** April 23  
**Agency:** North Hennepin Community College  
**Deliver to:** Brooklyn Park  
**Requisition #:** B 27153-10400

**Commodity:** B G—Talaris & digital printer supplies  
**Contact:** Bernadette Vogel 612-296-3778  
**Bid due date at 4:30pm:** April 23  
**Agency:** Minnesota Pollution Control Agency  
**Deliver to:** St. Paul  
**Requisition #:** B 32300-31262

**Commodity:** B F—Video equipment  
**Contact:** Pam Anderson 612-296-1053  
**Bid due date at 4:30pm:** April 23  
**Agency:** Department of Finance  
**Deliver to:** St. Paul  
**Requisition #:** B 10000-04593

**Commodity:** B F—Rolling overhead service doors  
**Contact:** Pam Anderson 612-296-1053  
**Bid due date at 4:30pm:** April 23  
**Agency:** Minnesota Correctional Facility—Faribault  
**Deliver to:** Faribault  
**Requisition #:** B 78790-20692

**Commodity:** B F—Mac supplier  
**Contact:** Bernadette Vogel 612-296-3778  
**Bid due date at 4:30pm:** April 23  
**Agency:** Minnesota Department of Health  
**Deliver to:** Minneapolis  
**Requisition #:** B 12500-86926

**Commodity:** Screens—must have ASCII keyboard and I  
**Contact:** Bernadette Vogel 612-296-3778  
**Bid due date at 4:30pm:** April 23  
**Agency:** Trade & Economic Development/Fiscal Services  
**Deliver to:** St. Paul  
**Requisition #:** B 22400-05833

**Commodity:** B E—Miscellaneous lab equipment  
**Contact:** Bernadette Vogel 612-296-3778  
**Bid due date at 4:30pm:** April 23  
**Agency:** Vermilion Community College  
**Deliver to:** Ely  
**Requisition #:** B 27147-47445

**Commodity:** B F—Polyscience polarimeter  
**Contact:** Bernadette Vogel 612-296-3778  
**Bid due date at 4:30pm:** April 23  
**Agency:** Lakewood Community College  
**Deliver to:** White Bear Lake  
**Requisition #:** B 27154-47387

**Commodity:** B G—Upgrade CCTV system  
**Contact:** Pam Anderson 612-296-1053  
**Bid due date at 4:30pm:** April 29  
**Agency:** Department of Public Safety  
**Deliver to:** St. Paul  
**Requisition #:** B 07300-34031

**Commodity:** B F—Red oak panels  
**Contact:** Pam Anderson 612-296-1053  
**Bid due date at 4:30pm:** April 23  
**Agency:** Minnesota Correctional Facility  
**Deliver to:** Red Wing  
**Requisition #:** B 78760-03102

## State Contracts and Advertised Bids

**Commodity:** B F—Steel doors  
**Contact:** Pam Anderson 612-296-1053  
**Bid due date at 4:30pm:** April 23  
**Agency:** Minnesota Correctional Facility—Faribault  
**Deliver to:** Faribault  
**Requisition #:** B 78790-20693

**Commodity:** B G K M—Copier rental  
**Contact:** Jack Bauer 612-296-2621  
**Bid due date at 4:30pm:** April 24  
**Agency:** Administrative State Employee Asst. Prog.  
**Deliver to:** St. Paul  
**Requisition #:** B 02111-21260

**Commodity:** B F—Holsters  
**Contact:** Jack Bauer 612-296-2621  
**Bid due date at 4:30pm:** April 24  
**Agency:** Department of Public Safety/Finance  
**Deliver to:** St. Paul  
**Requisition #:** B 07500-27196

**Commodity:** A H K M—Copier purchase  
**Contact:** Jack Bauer 612-296-2621  
**Bid due date at 4:30pm:** April 24  
**Agency:** Department of Natural Resources—Regional Headquarters  
**Deliver to:** Rochester  
**Requisition #:** B 29005-16034

**Commodity:** B F—All terrain vehicle  
**Contact:** Mary Jo Bruski 612-296-3772  
**Bid due date at 4:30pm:** April 24  
**Agency:** Department of Natural Resources—Regional Headquarters  
**Deliver to:** Bemidji  
**Requisition #:** B 29001-19449

**Commodity:** B G—Cut-off saw & accessories  
**Contact:** Mary Jo Bruski 612-296-3772  
**Bid due date at 4:30pm:** April 23  
**Agency:** Minnesota Correctional Facility  
**Deliver to:** Stillwater  
**Requisition #:** B 78620-00442

**Commodity:** B F K M—Platform scale  
**Contact:** Jack Bauer 612-296-2621  
**Bid due date at 4:30pm:** April 24  
**Agency:** Minnesota Department of Administration  
**Deliver to:** St. Paul  
**Requisition #:** B 02518-20537

**Commodity:** B G K M—Copier rental  
**Contact:** Jack Bauer 612-296-2621  
**Bid due date at 4:30pm:** April 24  
**Agency:** Minnesota Department of Jobs & Training  
**Deliver to:** Faribault  
**Requisition #:** B 21200-51476

**Commodity:** B G—Snowmobile trailers  
**Contact:** Mary Jo Bruski 612-296-3772  
**Bid due date at 4:30pm:** April 24  
**Agency:** Department of Natural Resources—Regional Headquarters  
**Deliver to:** Bemidji  
**Requisition #:** B 29001-19447

**Commodity:** B F—Sprinklers & nozzles  
**Contact:** Mary Jo Bruski 612-296-3772  
**Bid due date at 4:30pm:** April 24  
**Agency:** Department of Natural Resources—Badoura Nursery  
**Deliver to:** Akeley  
**Requisition #:** B 29003-04156

**Commodity:** A I—Drill rig & truck  
**Contact:** Mary Jo Bruski 612-296-3772  
**Bid due date at 2pm:** April 27  
**Agency:** Minnesota Department of Transportation  
**Deliver to:** Fort Snelling  
**Requisition #:** B 79382-02384-1

**Commodity:** First aid kits and supplies  
**Contact:** Cherie Ackerman 612-296-3776  
**Bid due date at 2pm:** April 30  
**Agency:** Various  
**Deliver to:** Various  
**Requisition #:** Price contract

**Commodity:** Furniture: ergonomic/orthopedic chairs and stools  
**Contact:** Patricia Anderson 612-296-3770  
**Bid due date at 2pm:** April 28  
**Agency:** Various  
**Deliver to:** Various  
**Requisition #:** Price contract

**Commodity:** B G—Centrifuge  
**Contact:** Bernadette Vogel 612-296-3778  
**Bid due date at 4:30pm:** April 24  
**Agency:** Minnesota Department of Health  
**Deliver to:** Minneapolis  
**Requisition #:** B 12400-86886

**Commodity:** B F—Guard posts—treated  
**Contact:** Pam Anderson 612-296-1053  
**Bid due date at 4:30pm:** April 24  
**Agency:** Minnesota Department of Transportation  
**Deliver to:** Rochester  
**Requisition #:** B 79600-04433

**Commodity:** B F—Fixtures and exit signs  
**Contact:** Joan Breisler 612-296-9071  
**Bid due date at 4:30pm:** April 24  
**Agency:** Minnesota Department of Transportation  
**Deliver to:** Rochester  
**Requisition #:** B 79000-23208

**Commodity:** B F—Metal flat seals  
**Contact:** Linda Parkos 612-296-3725  
**Bid due date at 4:30pm:** April 22  
**Agency:** Department of Natural Resources—Bureau of License  
**Deliver to:** St. Paul  
**Requisition #:** B 29000-58109

**Commodity:** A H L—Doors locks and hardware  
**Contact:** Linda Parkos 612-296-3725  
**Bid due date at 2pm:** April 22  
**Agency:** Brainerd Regional Human Services Center  
**Deliver to:** Brainerd  
**Requisition #:** B 55304-09173

**Commodity:** A I K M—Used press  
**Contact:** Jack Bauer 612-296-2621  
**Bid due date at 2pm:** April 24  
**Agency:** Minnesota Correctional Facility  
**Deliver to:** Lino Lakes  
**Requisition #:** B 78550-08482

**Commodity:** B G—Tire changer  
**Contact:** Mary Jo Bruski 612-296-3772  
**Bid due date at 4:30pm:** April 27  
**Agency:** Minnesota Department of Transportation  
**Deliver to:** Duluth  
**Requisition #:** B 79000-23023

**Commodity:** B G L—Express 386/33 computer  
**Contact:** Bernadette Vogel 612-296-3778  
**Bid due date at 4:30pm:** April 24  
**Agency:** Inver Hills Community College  
**Deliver to:** Inver Grove Heights  
**Requisition #:** B 27157-48763

**Commodity:** B F—Indoor concrete work  
**Contact:** Pam Anderson 612-296-1053  
**Bid due date at 4:30pm:** April 24  
**Agency:** Department of Public Service  
**Deliver to:** Roseville  
**Requisition #:** B 80300-92243

**Commodity:** A H—7 passenger mini van  
**Contact:** Brenda Thielen 612-296-9075  
**Bid due date at 2pm:** April 24  
**Agency:** Central Motor Pool  
**Deliver to:** St. Paul  
**Requisition #:** B 02514-20185

**Commodity:** Weather port dome  
**Contact:** Linda Parkos 612-296-3725  
**Bid due date at 2pm:** April 27  
**Agency:** Department of Natural Resources—Peterson Hatchery  
**Deliver to:** Peterson  
**Requisition #:** B 29005-16050

**Commodity:** B F—Air purification  
**Contact:** Linda Parkos 612-296-3725  
**Bid due date at 4:30pm:** April 21  
**Agency:** Minnesota Correctional Facility  
**Deliver to:** Faribault  
**Requisition #:** B 78790-20647

**Commodity:** B E—Farm King rear mower  
**Contact:** Mary Jo Bruski 612-296-3772  
**Bid due date at 4:30pm:** April 27  
**Agency:** Minnesota Correctional Facility  
**Deliver to:** St. Cloud  
**Requisition #:** B 78830-11195

**Commodity:** B E—Transmission jack  
**Contact:** Mary Jo Bruski 612-296-3772  
**Bid due date at 4:30pm:** April 27  
**Agency:** Minnesota Department of Transportation  
**Deliver to:** Duluth  
**Requisition #:** B 79000-23201

**Commodity:** B F—Used towed asphalt paver  
**Contact:** Mary Jo Bruski 612-296-3772  
**Bid due date at 4:30pm:** April 24  
**Agency:** Minnesota Department of Transportation  
**Deliver to:** Virginia  
**Requisition #:** B 79382-02414

## Department of Administration: Print Communications Division

Printing vendors for the following printing contracts must review contract specifications in printing buyers office at 117 University Avenue, Room 134-B, St. Paul, MN.

**Printing vendors NOTE: Other printing contracts can be found in the Materials Management Division listing above, and in the Professional, Technical & Consulting Contracts section immediately following this section.**

**Commodity:** Determination order, one-sided, 30M continuous sets, camera ready copy, carbonless, perforating  
**Contact:** Printing Buyer's Office  
**Bids are due:** April 21  
**Agency:** Human Services  
**Deliver to:** Federal Surplus Property, New Brighton  
**Requisition #:** 22438

**Commodity:** Brainerd Community College catalog, 112pp + bid on additional sigs, 8½x11, 4-color, camera ready copy, 12M  
**Contact:** Printing Buyer's Office  
**Bids are due:** April 23  
**Agency:** Brainerd Community College  
**Deliver to:** Brainerd  
**Requisition #:** 22449

**Commodity:** Woodworking for wildlife, 185 images, 35mm slides, 3-color print, 116pp + cover, 8½x11  
**Contact:** Printing Buyer's Office  
**Bids are due:** May 6  
**Agency:** Print Communications Bookstore  
**Deliver to:** St. Paul  
**Requisition #:** 22248

**Commodity:** 1993 MN state parks vehicle permit, camera ready copy, two-sided, head-to-head, 135M, padding  
**Contact:** Printing Buyer's Office  
**Bids are due:** April 23  
**Agency:** Natural Resources  
**Deliver to:** St. Paul  
**Requisition #:** 22468

**Commodity:** Cashed tickets envelope, type to be set, 8"x6½", green ink, logo, 8M  
**Contact:** Printing Buyer's Office  
**Bids are due:** April 22  
**Agency:** Minnesota State Lottery  
**Deliver to:** Roseville  
**Requisition #:** 22455

**Commodity:** Blufflands poster, camera ready copy, one-sided, 1M, 100# white 4-color process chromalin  
**Contact:** Printing Buyer's Office  
**Bids are due:** April 22  
**Agency:** Natural Resources  
**Deliver to:** St. Paul  
**Requisition #:** 22364

## State Contracts and Advertised Bids

**Commodity:** 1993 MN state parks catalog, camera ready copy, 6,500 copies, 24pp + cover, color seps  
**Contact:** Printing Buyer's Office  
**Bids are due:** April 23  
**Agency:** Natural Resources  
**Deliver to:** St. Paul  
**Requisition #:** 22451

**Commodity:** Retailer settlement envelope, type to be set, 20# white  
**Contact:** Printing Buyer's Office  
**Bids are due:** April 22  
**Agency:** Minnesota State Lottery  
**Deliver to:** Roseville  
**Requisition #:** 22456

### Minnesota's North Shore

**Historic Sites and Place Names of Minnesota North Shore.** Stories recounted by a retired DNR Forester about the North Shore's timbermen, pioneer settlers, commercial fishermen, and others who knew the area first hand. Stock #9-11. 35pp. \$3.50 + tax.

**Up North.** A memorable collection of essays and stories that capture the mystic moods, seasonal subtleties and colorful characters that fill the landscape up north. Stock #19-16. \$16.95 + tax.

**A Family Guide to Minnesota's North Shore.** The 150 miles from Duluth to the Canadian border offer travelers wilderness experiences, places of historic significance, and visions of astonishing beauty. Stock #19-84. \$3.95 + tax.

**Boundary Waters.** Almost 100 pages of beautiful color photographs of Minnesota's canoe country, by Jerry Stebbins with rich text by Greg Breining. Stock #19-69. \$24.99 + tax.

**A Paddler's Guide to the Boundary Waters Canoe Area,** 78 pages of detailed maps and descriptions of 31 wilderness canoe routes in the Superior National Forest of Northern Minnesota. Includes what to bring along on canoe trips, regulations, canoe tips and detailed information for self-guided tours. Stock #19-17, \$4.95.

**TO ORDER:** Send to Minnesota's Bookstore, 117 University Avenue, St. Paul, MN 55155. Call (612) 297-3000, or toll-free in Minnesota: 1-800-657-3757. Minnesota residents please include 6½% sales tax. On all orders, add \$2.00 per order for handling. Prepayment is required. Please include daytime phone. VISA/MasterCard, American Express and Discover orders accepted over phone and through mail. **Prices are subject to change.** FAX: (612) 296-2265.



Publication editors: As a public service, please reprint this ad in your publication as is, reduced, enlarged, or redesigned to suit your format. Thank you.

### River Stories That Warm Your Heart

**A Stretch on the River.** 1950 novel about the son of a wealthy family who goes to work on a Mississippi River towboat to avoid being drafted. With power, gusto and humor, author Richard Bissel creates an energetic, rowdy, and delightful account of a typical trip up the river, accurately re-creating a colorful era of towboating on America's major waterway. Stock #17-6. \$8.95 plus tax.

**High Water.** During the worst flood on the Mississippi River anyone can remember, the mate of a towboat has his hands full on a perilous trip, working with an unhappy crew, an angry captain, and too many barges to push against too much river. A 1954 Richard Bissel novel reveals the drama, humor and charm of working on the river. Stock #17-8. \$8.95 plus tax.

**Old Times on the Mississippi River.** George Merrick's lively, loving, and humorous reminiscences of his steamboat life from the bottom up, as a pantry boy, apprentice engineer, second clerk, and "cub" pilot. First published in 1909, he describes steamboat operations—from machinery and personnel to the economics of the business—with vivid examples and rich detail. 323 pp. includes appendices and index. Stock #17-45. \$8.95 plus tax.

**Canoeing with the Cree.** Minnesota's distinguished newsman, Eric Sevareid, wrote his first book in 1935 about a canoe journey he and a classmate made to Hudson Bay. The classic recounts their trip on the Mississippi, Minnesota and Red River of the North Rivers into Lake Winnipeg, and then God's River to Hudson Bay. 209 pp. includes index, maps and photos. Stock #17-14. \$6.95 plus tax.

**TO ORDER:** Send to Minnesota's Bookstore, 117 University Avenue, St. Paul, MN 55155. Call (612) 297-3000, or toll-free in Minnesota: 1-800-657-3757. Minnesota residents please include 6½% sales tax. On all orders, add \$2.00 per order for handling. Prepayment is required. Please include daytime phone. VISA/MasterCard, American Express and Discover orders accepted over phone and through mail. **Prices are subject to change.** FAX: (612) 296-2265.



Publication editors: As a public service, please reprint this ad in your publication, either as is, reduced, or redesigned to suit your format.

# MAILING LISTS GALORE

## Successful business means successful sales

The Print Communications Division has a variety of mailing lists of licensed professionals and permit holders that will enable you to focus your marketing efforts on a targeted audience.

Types of lists available are: registered nurses, real estate agents, physicians, insurance agents, boatowners, hunters, cosmetologists, teachers, and many more! And you can get them on printouts, cheshire/pressure sensitive labels, as well as 9-track magnetic tapes.

What's more, you can choose from several selection capabilities. You will find our selections most helpful and beneficial to your business when you learn that you can acquire names and addresses of individuals in the areas you need to target most.

Find out more about our mailing lists by writing for our free mailing list catalog. In a hurry? Call (612) 296-0930 for more information. Requests can be sent to: Print Communications Division, Mailing List Service, 117 University Avenue, St. Paul, MN 55155. FAX: (612) 296-2265.

Publication editors: As a public service, please reprint this ad in your publication as is, reduced, enlarged, or redesigned to suit your format. Thank you.

## Minnesota Manufacturer's Directory 1992



UPDATED: Name, address, phone number, staff size, sales volume, market area, year of establishment, type of firm, C.E.O., Sales or Marketing Manager, Purchasing Manager and four major manufactured products. Code #40-2. \$90.00.

NEW: In the directory this year are two titles (where applicable) Chief Engineer and Data Processing Manager.



**TO ORDER:** Send to Minnesota's Bookstore, 117 University Avenue, St. Paul, MN 55155. Call (612) 297-3000, or toll-free in Minnesota: 1-800-657-3757. Minnesota residents please include 6½% sales tax. On all orders, add \$2.00 per order for handling. Prepayment is required. Please include daytime phone. VISA/MasterCard, American Express and Discover orders accepted over phone and through mail. **Prices are subject to change.** FAX: (612) 296-2265.

Publication editors: As a public service, please reprint this ad in your publication as is, reduced, enlarged, or redesigned to suit your format. Thank you.

## Voices of the Loon

Its voice severs the bonds to the world of cities, traffic, crowds, lights and noise. The lyrical magic of the loon, sometimes hauntingly eerie, makes the skin tingle, and the hair on the back of the neck stand on edge, awakening a primitive response. Its solitary wail turns the shadowy wilderness into a mysterious path into eternity.

**Voices of the Loon**, cassette tape, includes introduction and loon call identification, chorus from a distant lake, tremolo duet, wail duet, border confrontation, wails with morning songbird chorus, tremolos while running, wails during a thunderstorm, and coyotes calling with loons. Code #19-73, \$12.00.

**The Loon: Voice of the Wilderness**, hardbound with color plates and illustrations, 143 pages. Code #19-54, \$16.95.

**Love of Loons**. A Voyageur Wilderness Book, with color photos and lore of this delightful state bird makes this a beautiful gift. Stock #9-22, \$12.95 + tax.

**Loon Lapel Pin**. Code #15-30, \$2.49.

**Loon Windsock**, 56 inches long in full color. Code #15-29, \$19.95.

**Loon Nature Print**, full-color poster 16" x 22", Code #15-18, \$3.00.

**Loon with Baby**—poster, 16" x 20". Code #15-48, \$3.00.

**TO ORDER:** Send to Minnesota's Bookstore, 117 University Avenue, St. Paul, MN 55155. Call (612) 297-3000, or toll-free in Minnesota: 1-800-657-3757. Minnesota residents please include 6½% sales tax. On all orders, add \$2.00 per order for handling. Prepayment is required. Please include daytime phone. VISA/MasterCard, American Express and Discover orders accepted over phone and through mail. **Prices are subject to change.** FAX: (612) 296-2265.



Publication editors: As a public service, please reprint this ad in your publication, either as is, reduced, or redesigned to suit your format.

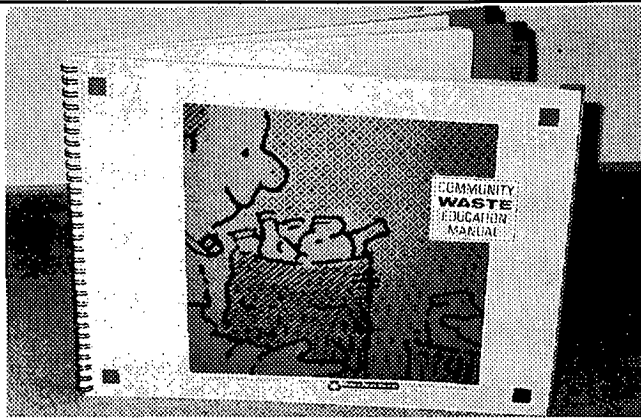

*Community Waste Education Manual* available at Minnesota's Bookstore

**NEW—Reduced Price!**

## Waste Education Campaigns

The **COMMUNITY WASTE EDUCATION MANUAL** offers practical guidance to help communities develop waste education campaigns. Tremendous step-by-step guide to organizing volunteers, planning a budget, working with media and more. Includes camera-ready art and copy for media and publication needs. 82 pp. Produced by the Minnesota Office of Waste Management. Stock #5-7. **Now only \$9.95.**

**TO ORDER:** Send to Minnesota's Bookstore, 117 University Avenue, St. Paul, MN 55155. Call (612) 297-3000, or toll-free in Minnesota: 1-800-657-3757. Minnesota residents please include 6½% sales tax. On all orders, add \$2.00 per order for handling. Prepayment is required. Please include daytime phone. VISA/MasterCard, American Express and Discover orders accepted over phone and through mail: *Prices are subject to change.* FAX: (612) 296-2265.

Publication editors: As a public service, please reprint this ad in your publication as is, reduced, enlarged, or redesigned to suit your format. Thank you.

## Manage Change and Information Plans

**Managing Change.** A guide to managing change from *within* an organization, it combines common sense with solid theory about organizational behavior and change. Based on the premise: for an enterprise to succeed, employees must be involved as active partners. Operating in an environment of change, government adapts to newly elected officials, new political appointees, new economic conditions, new laws and rules, new managers and employees, and new mandates and priorities. Through the STEP plan, government capitalizes on that change by emphasizing closeness to the customer, employee participation, managerial discretion, partnerships, productivity improvement and work measurement. Contains a project directory and glossary. Paperbound, 181 pages. Stock #19-64, \$19.00.

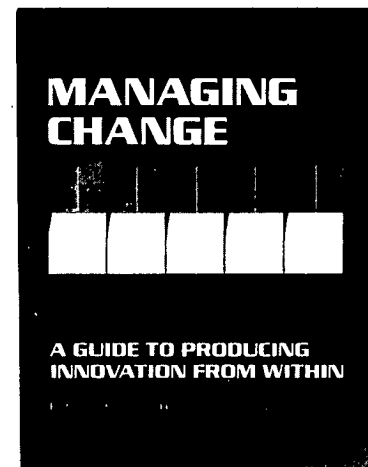

**TO ORDER:** Send to Minnesota's Bookstore, 117 University Avenue, St. Paul, MN 55155. Call (612) 297-3000, or toll-free in Minnesota: 1-800-657-3757. Minnesota residents please include 6½% sales tax. On all orders, add \$2.00 per order for handling. Prepayment is required. Please include daytime phone. VISA/MasterCard, American Express and Discover orders accepted over phone and through mail. FAX: (612) 296-2265. *Prices subject to change.*

Publication editors: As a public service, please reprint this ad in your publication as is, reduced, enlarged, or redesigned to suit your format. Thank you.

## Minnesota: national leader in education

### 101 Ways to Promote Academic Excellence

A collection of nuts-and-bolts methods educators have successfully used to foster academic achievement. These are techniques that directly help students, can be replicated easily, are cost-effective, and that work in meeting the public educators' great challenge: helping every single child learn. Code #5-1, \$4.50.

### Education Directory, 1991-92

This popular comprehensive directory contains Minnesota school districts, superintendents, principals, addresses, phone numbers and enrollment. 170 pages, paperbound. Code #1-93, \$9.95.

**TO ORDER:** Send to Minnesota's Bookstore, 117 University Avenue, St. Paul, MN 55155. Call (612) 297-3000, or toll-free in Minnesota: 1-800-657-3757. Minnesota residents please include 6½% sales tax. On all orders, add \$2.00 per order for handling. Prepayment is required. Please include daytime phone. VISA/MasterCard, American Express and Discover orders accepted over phone and through mail. *Prices are subject to change.* FAX: (612) 296-2265.

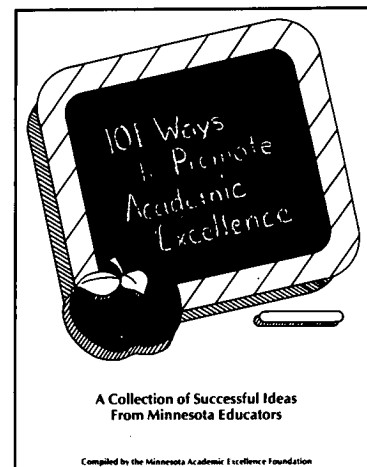

Publication editors: As a public service, please reprint this ad in your publication as is, reduced, enlarged, or redesigned to suit your format. Thank you.

# Minnesota's Bookstore

---

---

## Publications, Services, Subscriptions

### Order Form on Back—For Information, Call 297-3000

**1991 Minnesota Rules.** Eleven volume set includes 1992 Supplement as a subscription service. Stock #18-100, \$200 + tax (Minnesota residents only). Individual volumes can be purchased at \$20.00 + tax.

**1991 Minnesota Session Laws.** Two volume set includes laws passed during the 1991 session. Stock #18-1, \$32.00 + tax.

**101 Ways to Promote Academic Excellence.** A collection of nuts-and-bolts methods educators have successfully used to foster academic achievement. These are techniques that directly help students, can be replicated easily, are cost-effective, and that work in meeting the public education's great challenge: helping every single child learn. Code #5-1, \$4.50.

**1989 Pollution Control Laws.** Laws dealing with water pollution, disposal facilities, solid waste management, the Minnesota Environmental Rights Act, recycling, and more. Code #2-21, \$24.95.

**1991 Hazardous Waste Rules.** Governs the production, storage, transportation and disposal of hazardous waste. *Minnesota Rules* Chapter 7045 and 7046. Code #3-71, \$17.95.

**Real Estate Rules 1991.** Chapters 2800, 2805 and 2810 from the *Minnesota Rules*. Essential for both students and established brokers and salespersons. It contains all education and licensing requirements. Code #3-99, \$6.00.

**Police Report Writing Style Manual 1989.** A common framework for report writing throughout the state. Discusses the general purpose of police reports, reviews field notetaking, offers instructions on completing common report forms and introduces the Data Practices Law. Code #14-13, \$15.00.

### OTHER PUBLICATIONS

**Voices of the Loon.** Includes introduction, loon call identification, distant chorus, tremolo duet, wail duet, border confrontation, wails with morning songbird chorus, tremolos while running, wails during thunderstorm and coyotes calling with loons. Cassette tape. Code #19-73, \$12.00.

**Secrets of the Congdon Mansion.** A complex, intriguing murder case set in one of Minnesota's most spectacular mansions. Now a top Minnesota tourist attraction on Duluth's famous Lake Superior North Shore Drive. By Joe Kimball. Code #19-56, \$5.95.

**A Paddler's Guide to the Boundary Waters Canoe Area.** Advice on what to bring along on canoe trips, regulations, canoe tips and detailed information for self-guided tours. Includes detailed maps and descriptions of 31 wilderness canoe routes in the Superior National Forest of Northern Minnesota. Stock #19-17, \$4.95.

**Minnesota Geographic Names.** Names of places by the thousand plus interesting historical tidbits included in this 800+ page book. Minnesota history buffs—this is for you! Stock #17-13, \$12.95.

**Room at the Inn Minnesota.** The only guide to more than 60 historic Bed & Breakfast homes, hotels and country inns. Stock #19-72, \$9.95.

**Minnesota Manufacturer's Directory, 1992.** More than 7,000 entries listing name, address, phone, staff size, sales volume, market area, year of establishment, type of firm, CEO, sales or marketing and purchase managers, and four manufactured products. Stock #40-2, \$90.00. Directory will also be available on Computer Diskette. Call for further information.

### SUBSCRIPTIONS:

**State Register.** Minnesota's official weekly publication for agency rules and notices, executive orders of the Governor, state contracts, Supreme Court Calendar, Supreme Court and Tax Court Decisions. Annual subscription: Monday edition only \$140; Monday and Thursday's State Contract Supplement \$195; 13-week trial (includes both Monday and Thursday editions) \$60.00.

**Workers Compensation Decisions.** Volume 45. Selected landmark decisions of the Worker's Compensation Court of Appeals during the period July '91 through Dec. '91. The subscription rate for this volume is \$160.00.

### SERVICES:

**Mailing Lists.** Lists of Minnesota licensed professionals and permit holders. Write or call (612) 297-2552 for a free mailing list catalog which contains available lists, selections, formats, pricing and ordering information.

**American Flag.** Perfect for home or office. 3' x 5' with embroidered stars. Heavy nylon bunting. Code No. 6-1. \$21.00 + tax.

**1991 Lake Map Index.** Listing over 4,000 lake maps. Free.

**State Register Binder.** Durable 3½ inches, forest green binders imprinted with the *State Register* logo. \$6.50 + tax.

