

CHAPTER 1325
DEPARTMENT OF ADMINISTRATION
MINNESOTA STATE BUILDING CODE
ENERGY

SOLAR ENERGY SYSTEMS	
1325.1000	DEFINITIONS.
1325.1100	PURPOSE OF SOLAR ENERGY RULES.
1325.1200	ENFORCEMENT.
1325.1300	SELLER'S DISCLOSURE.
1325.1400	FORM OF DISCLOSURE STATEMENT.
1325.1500	STANDARDS FOR EVALUATION OF SOLAR ENERGY SYSTEMS.
1325.1600	DURABILITY AND RELIABILITY OF SOLAR SYSTEMS.
1325.1700	SERVICE LOADS.
1325.1800	MECHANICAL STRESSES.
1325.1900	TEMPERATURE AND PRESSURE RESISTANCE.
1325.2000	MATERIALS COMPATIBILITY.
1325.2100	EROSION, CORROSION.
1325.2200	HEAT OR HUMIDITY TRANSFER EFFECTS.
1325.2300	EFFECTS OF EXTERNAL ENVIRONMENT.
1325.2400	MAINTAINABILITY.
1325.2500	STANDARDS FOR EVALUATION OF SOLAR SUBSYSTEMS.
1325.2600	COLLECTOR SUBSYSTEMS.
1325.2700	TRANSPORT AND STORAGE SUBSYSTEMS.
1325.2800	CONTROL SUBSYSTEMS.
1325.2900	REFERENCE STANDARDS AND TEST METHODOLOGY.
1325.3000	EXPLANATION OF SYMBOLS FOR CALCULATIONS.
1325.3100	CALCULATION PROCEDURES FOR SOLAR SYSTEMS.
1325.3200	MEASUREMENTS FOR SPECIFIC SYSTEMS.
1325.3300	DETERMINING MONTHLY LOAD.
1325.3400	DETERMINING THE MONTHLY INCIDENT SOLAR RADIATION.
1325.3500	PREDICTING SYSTEM PERFORMANCE.
1325.3600	ANNUAL FRACTION OF THE TOTAL HEATING LOAD SUPPLIED BY SOLAR ENERGY (F ANNUAL).
1325.9000	TABLE FOR CALCULATING LOADS.
1325.9100	TABLE FOR TABULATING INCIDENT SOLAR RADIATION CALCULATION.
1325.9200	MONTHLY AVERAGES OF DAILY RADIATION.
1325.9300	RATIO OF AVERAGE DAILY RADIATION ON TILTED SURFACE TO THAT ON HORIZONTAL SURFACE.
1325.9400	FIGURES.
1325.9500	TABLE FOR CALCULATING FRACTION OF HEATING LOAD SUPPLIED BY SOLAR ENERGY.

1325.0200 [Repealed, 8 SR 1229]

1325.0300 [Repealed, 8 SR 1229]

1325.0400 [Repealed, 8 SR 1229]

1325.0500 [Repealed, 8 SR 1229]

1325.0600 [Repealed, 8 SR 1229]

1325.0700 [Repealed, 8 SR 1229]

SOLAR ENERGY SYSTEMS

1325.1000 DEFINITIONS.

Subpart 1. **Abbreviations.** DHW, domestic hot water; H, heating; HC, heating/cooling; UV, ultraviolet.

Subp. 2. **Absorptance.** "Absorptance" means the ration of the amount of radiation absorbed by a surface to the amount of radiation incident upon it.

Subp. 3. **Absorptivity.** "Absorptivity" means the capacity of a material to absorb radiant energy.

Subp. 4. **Active solar system.** "Active solar system" (flat plate or concentrating collector based) means a system characterized by the use of powered mechanical equipment to move the heat transfer fluid (liquid or gas) through a collector and from a collector to load or storage.

Subp. 5. **Auxiliary energy subsystem.** "Auxiliary energy subsystem" means equipment utilizing conventional energy sources both to supplement the output provided by the solar energy system and to provide full energy backup during periods when the solar H or DHW systems are inoperable.

Subp. 6. **Cathodic protection.** "Cathodic protection" means corrosion protection against electrolytic reactions.

Subp. 7. **Chemical compatibility.** "Chemical compatibility" means the ability of materials and components in contact with each other to resist mutual chemical degradation, such as the chemical degradation caused by electrolytic action or plasticizer migration.

Subp. 8. **Collector efficiency.** "Collector efficiency" (instantaneous) means the ratio of the amount of energy removed by the transfer fluid per unit of aperture (entrance window area) over a 15-minute period to the total incident solar radiation onto the same collector area for the same 15-minute period (as defined by NBSIR 74-635).

Subp. 9. **Collector subsystem.** "Collector subsystem" means the assembly for absorbing solar radiation, converting it into thermal energy, and transferring the thermal energy to a heat transfer fluid.

Subp. 10. **Combined system.** "Combined system" (combined collectors and storage devices) means a combined component system characterized by a system with integral construction and operation of the components such that the solar radiation collection and storage phenomena cannot be measured separately in terms of flow rate and temperature changes.

Subp. 11. **Control subsystem.** "Control subsystem" means an assembly of devices and its electrical, pneumatic, or hydraulic auxiliaries used to regulate the processes of collecting, transporting, storing, and utilizing energy.

Subp. 12. **Design life.** "Design life" means the period of time during which a solar energy system or component is expected to perform without major maintenance or replacement.

Subp. 13. **Dielectric fitting.** "Dielectric fitting" means an insulating or non-conducting fitting used to isolate electrochemically dissimilar materials.

Subp. 14. **Emittance.** "Emittance" means the ratio of the radiant energy emitted by a body to the radiant energy emitted by a black body at the same temperature.

Subp. 15. **Facility.** "Facility" means a building or structure including appliances, heating or cooling equipment, industrial or manufacturing processes to be served by the solar energy system.

Subp. 16. **Flow condition.** "Flow condition" means the condition existing in the solar energy system when the heat transfer fluid is flowing through the collector under normal operating conditions.

Subp. 17. **Fluid requiring special handling.** "Fluid requiring special handling" means fluid which is a "highly toxic substance" or a "toxic substance" as defined by paragraphs 191.1(e) and (f) of the federal Hazardous Substances Labeling Act, regulations, part 191, chapter I, title 21(A); or fluid having a degree of flammability such that it is a "flammable substance" or an "extremely flammable substance" as defined by application of the Tagliabue Open Cup Flash Point Test (stated in the Hazardous Substances Act, Public Law 86-613, July 12, 1960).

Subp. 18. **Heat generated cooling.** "Heat generated cooling" means the use of thermal energy to operate an absorption refrigerating unit.

Subp. 19. **Heating degree days.** "Heating degree days" means the number of degrees that the daily mean temperature is below 18.3 degrees Celsius (65 degrees Fahrenheit).

Subp. 20. **Maximum "flow" temperature.** "Maximum 'flow' temperature" means the maximum temperature obtained in a component when the heat transfer fluid is flowing through the system.

Subp. 21. **Maximum "no flow" temperature.** "Maximum 'no flow' temperature" means the maximum temperature obtained in a component when the heat transfer fluid is not flowing through the system.

Subp. 22. **Maximum service temperature.** The "maximum service temperature" means the maximum temperature to which a component will be exposed in actual service, either with or without the flow of heat transfer fluid.

Subp. 23. **Operating energy.** "Operating energy" means the conventional energy required to operate the H, HC and HW systems, excluding any auxiliary energy which supplements the solar energy collected by the systems (e.g., the electrical energy required to operate the energy transport and control subsystems).

Subp. 24. **Outgassing.** "Outgassing" means the emission of gases by component materials usually during exposure to elevated temperature or reduced pressure.

Subp. 25. **Passive solar system.** "Passive solar system" (integral collector, storage, and building) means a passive system characterized by collector and storage components which are an integral part of the building. Auxiliary energy may be used for control purposes but heating is achieved by natural heat transfer phenomena. Roof ponds, modified walls, roof sections with skylights, or similar applications where solar energy is used to supply a measurable fraction of the building heating requirements are examples of passive systems.

Subp. 26. **Solar energy system.** "Solar energy system" means an assembly of subsystems and components which is designed to convert solar energy into thermal energy.

Subp. 27. **Transmittance.** "Transmittance" means the ratio of the radiant flux transmitted through and emerging from a body to the total flux incident on it.

Statutory Authority: *MS s 216C.25*

1325.1100 PURPOSE OF SOLAR ENERGY RULES.

Subpart 1. **Authority.** These rules are authorized by Minnesota Statutes 1976, sections 116H.127 and 16.85 and established through the rulemaking procedures set forth at Minnesota Statutes, chapter 14.

Subp. 2. **Scope.** These rules shall apply to solar energy systems which are used to satisfy space heating and/or space cooling and/or domestic or service hot water demands of buildings, and shall be used for all solar energy systems and subsystems as those terms are defined at part 1325.1000 herein. These rules are to be used in conjunction with existing building codes and standards and do not replace existing building codes.

Subp. 3. **Purpose.** The purpose of these rules is twofold: first, to establish standards for the evaluation of the performance, durability, reliability, and maintainability of solar energy systems and subsystems; and second, to require disclosure by the seller to each potential buyer of the extent to which the seller's solar energy system or subsystem meets or exceeds the standards set forth at parts 1325.1500 to 1325.2800.

Subp. 4. **Conformance with other standards.** The standards set forth in parts 1325.1500 to 1325.2800 are in reasonable conformance with Interim Performance Criteria for Commercial Solar Heating/Cooling Systems and Facilities (NASA), Interim Performance Criteria for Solar Heating and Combined Heating/Cooling Systems and Dwellings (NBS), and Intermediate Minimum Property Standards for Solar Heating and Domestic Hot Water Systems (HUD).

Subp. 5. **Standards not mandatory.** The standards set forth in parts 1325.1500 to 1325.2800 are intended to serve as a model for evaluating solar energy system or subsystem performance. These rules require that the seller determine and disclose the extent to which its system or subsystem meets or exceeds these standards. These rules do not require the seller to comply with the standards.

Statutory Authority: *MS s 216C.25*

History: *L 1987 c 384 art 2 s 1*

1325.1200 ENFORCEMENT.

Subpart 1. Building official's duties. The building official in each municipality shall enforce the rules set forth in part 1325.1300. The building official shall not issue any permits required for installation of the electrical, mechanical, or structural aspects of the solar energy system or subsystem until the seller has furnished the building official a copy of the completed disclosure statement form required by these rules. However, the building official shall not be required to determine the accuracy of the seller's disclosures or to otherwise determine the extent to which the seller's solar energy system or subsystem meets or exceeds the standards set forth in parts 1325.1500 to 1325.2800.

Subp. 2. Penalties. Any person who violates the provisions of these rules or knowingly submits false information in the required disclosure statement form shall be guilty of a misdemeanor and may be subject to a civil penalty of not more than \$10,000 for each violation. See Minnesota Statutes 1976, section 116H.15.

Statutory Authority: *MS s 216C.25*

1325.1300 SELLER'S DISCLOSURE.

Subpart 1. General requirement. Every seller of a solar energy system or subsystem shall inform every bona fide prospective buyer of the extent to which the seller's system or subsystem meets or exceeds the standards set forth at parts 1325.1500 to 1325.2800.

Subp. 2. Disclosure statement required. The information required by subpart 1 shall be provided on the disclosure statement form set forth at part 1325.1400, subparts 1 and 2.

Subp. 3. Operation manual. A copy of the operation and maintenance manual described at part 1325.2400 shall be available for review by a bona fide prospective buyer, and shall be provided to each buyer upon sale of the solar energy system or subsystem.

Subp. 4. Submitting form and copies. The seller of a solar energy system or subsystem shall complete the disclosure statement form, including part 1325.1400, subpart 3, and shall submit copies to the buyer at the time of sale and to the municipal building official prior to installation.

Subp. 5. ASHRAE Standard 93-77 required. Where the solar energy system or subsystem includes flat plate collectors, or any other collectors whose thermal performance is capable of being rated in accordance with ASHRAE Standard 93-77, Methods of Testing to Determine the Thermal Performance of Solar Collectors, such collectors shall be tested in accordance with the methods set forth at ASHRAE Standard 93-77. No other tests are required by these rules; however, the seller shall fully disclose on the disclosure statement form the basis for its determinations as required on the disclosure statement form, and where the determinations are not substantiated by testing, the seller shall so indicate.

Statutory Authority: *MS s 216C.25*

1325.1400 FORM OF DISCLOSURE STATEMENT.

Subpart 1. Purpose. The purpose of this statement is to disclose to the buyer the extent to which this system meets the standards for solar systems set forth in the State Building Code.

Subp. 2. How system meets standard. This system/subsystem/component meets or exceeds the standards set forth at parts 1325.1500 to 1325.2800 except as noted in subpart 3 below.

Subp. 3. Tests used. The seller's determination that these standards have or have not been met are based on the following tests, computations, and documentation, which are available for review by the buyer:

PART NUMBER
MINNESOTA RULES

TESTS, COMPUTATIONS,
AND DOCUMENTATION

Subp. 4. **How system does not meet standard.** This system (subsystem/component) does not meet or exceed the standards set forth at parts 1325.1500 to 1325.2800 in the following respects:

The seller may explain below any reasons for the system (subsystem or component) not meeting the standards set forth at Minnesota Rules, parts 1325.1500 to 1325.2800 and may indicate the extent to which the system does meet the standard.

Subp. 5. **Design life.** The manufacturer of solar energy systems shall outline herein the design life of systems and subsystems under anticipated design conditions. This is not a warranty or a guarantee of this life.

Design life of solar energy system, with normal maintenance as described by manufacturer _____.

Design life of subsystems and components, with normal maintenance as described by manufacturer.

- Collector subsystem _____
- Transport subsystem _____
- Storage subsystem _____
- Control subsystem _____

Subp. 6. **Solar energy system performance.** Sizing of the previously identified solar energy system is outlined below. All load calculations are performed in accordance with Minnesota Rules, part 1325.2900 or parts 1325.3000 to 1325.3600.

- Calculated facility heating consumption _____
- Calculated service hot water consumption _____
- Calculated facility cooling consumption _____
- Other calculated facility energy consumption _____
- as may be offset by solar energy system.
- Total calculated facility consumption _____

Solar contribution, as calculated in accordance with Minnesota Rules, parts 1325.3000 to 1325.3600, shall be provided as follows: (Calculations which have been substantiated by field testing of solar system/subsystems and components are an acceptable submission in lieu of calculation procedures, Minnesota Rules, parts 1325.3100 to 1325.3600.

- Calculated solar contribution to space heating consumption _____%
- Calculated solar contribution to service hot water consumption _____%
- Calculated solar contribution to facility cooling consumption _____%
- Calculated solar contribution to other consumption _____%
- Calculated solar contribution to total consumption _____%

Statutory Authority: *MS s 216C.25*

1325.1500 STANDARDS FOR EVALUATION OF SOLAR ENERGY SYSTEMS.

Subpart 1. **Scope.** Parts 1325.1500 to 1325.2400 contain design criteria for evaluation of performance and quality of solar systems.

Subp. 2. **Solar system performance.** The solar system shall be capable of collecting and converting solar energy into thermal energy. The thermal energy shall be used to meet the total energy needs for space heating, cooling, and water heating alone or in combination with storage and auxiliary energy, as required. The solar system shall supply more energy to the demand of the facility for which it is installed than is required for the solar systems.

Subp. 3. **Solar energy system sizing.** The solar system combination shall be

based upon monthly average heat loads determined by a degree day method using average monthly design temperature and conditions as the maximum analytical time interval. Building heat loss shall be determined by historical energy use data or calculation. Calculation of building heat loss for use in sizing solar energy systems shall be performed for the full heating and/or cooling season using the method described in parts 1325.3000 to 1325.3600.

Subp. 4. **Solar energy system contribution.** The average yearly contribution of solar energy to the operation of the solar systems shall be specified in the disclosure statement and shall result in a reduction in the annual consumption of conventional energy. The solar energy contribution shall be determined as a percentage of the average annual space conditioning and water heating energy requirements less solar system operating energy demand. Analytical simulations or correlations based upon simulations combining the building heating and cooling loads, solar system performance, and climatic conditions shall be utilized to predict the average monthly and annual energy contribution to be provided by solar energy, auxiliary energy, and electrical operating energy as illustrated in parts 1325.3000 to 1325.3600. (Calculations which have been substantiated by field testing of solar system/subsystems and components are an acceptable submission in lieu of parts 1325.3100 to 1325.3600.

Statutory Authority: *MS s 216C.25*

1325.1600 DURABILITY AND RELIABILITY OF SOLAR SYSTEMS.

The structural design of the solar system including connections and supporting structural elements shall be based on loads anticipated during the design life of the systems.

Statutory Authority: *MS s 216C.25*

1325.1700 SERVICE LOADS.

The following additional loads shall be used in the structural design of conventional and nonconventional elements and connections of H, HC and DHW systems:

A. Constraint loads caused by the environment, normal functioning of the system and time dependent changes within the materials of the system shall be taken as the most likely to be encountered during the design life.

B. Ice loads (I) shall be taken as those produced by the accumulation of ice on surfaces exposed to the natural environment. The thickness of ice shall be taken as a radial thickness of one-half inch.

C. Hail loads. System components and supporting structural elements that will be exposed to the natural environment in service shall be designed to resist, without excessive damage or major impairment of the functioning of the system, the perpendicular impact of falling hail having a particle diameter of three-fourths of an inch. "Excessive damage or major impairment" shall not include punching or local cracking of nonstructural elements such as glass cover plates of collector panels under hail impact, but shall include damage which creates a major curtailment in the functioning of the system, premature failure, or hazards created by excessive shattering of glazed elements.

Statutory Authority: *MS s 216C.25*

1325.1800 MECHANICAL STRESSES.

Subpart 1. **General.** Mechanical stresses that arise within the system shall not cause damage or malfunction of the system or its components.

Subp. 2. **Vibration stress levels.** Vibrations in collectors, piping, ducts, instrumentation lines, and control devices shall be controlled to reduce stress levels below those that could cause fatigue and subsequent component damage.

Subp. 3. **Components involving moving parts.** Components that involve mov-

ing parts shall be capable of performing their intended function without excessive wear or deterioration for their design lives with normal maintenance.

Subp. 4. Wear and fatigue. Check valves, pressure regulators, pumps, electrical switches, and similar components shall be capable of operating under in-use conditions for their design lifespans without exhibiting wear or fatigue to a degree that would affect the performance as declared in disclosure statement form.

Subp. 5. Flexible joints. All systems employing heat transfer fluids shall be designed to accommodate flexing of subsystems and components.

Statutory Authority: *MS s 216C.25*

1325.1900 TEMPERATURE AND PRESSURE RESISTANCE.

Subpart 1. General. Components shall be capable of performing their functions for their design lives when exposed to the temperatures and pressures that may develop in the system under both flow and no flow conditions.

Subp. 2. Thermal cycling stresses. The solar energy system shall be capable of withstanding the stresses induced by thermal cycling for their respective design lives.

Subp. 3. Thermal changes. The solar energy system shall be designed to allow for the thermal contraction and expansion that may occur over the service temperature range.

Subp. 4. Thermal degradation. Solar energy systems shall not thermally degrade to the extent that their function will be reduced to a degree that will affect the performance as declared in part 1325.2900.

Subp. 5. Relief valves and vents. As required for protection of a particular system design, combination temperature and pressure relief valves, vacuum relief valves, separate pressure relief valves, pressure reducing valves, and/or atmospheric vents shall be provided.

Statutory Authority: *MS s 216C.25*

1325.2000 MATERIALS COMPATIBILITY.

Subpart 1. General. All materials which are joined to or in contact with other materials shall have sufficient chemical compatibility with those materials to prevent deterioration that may impair their functions to a degree that would affect the performance as declared in disclosure statement form. Allowances shall be made for differences in the expansion of jointed materials.

Subp. 2. Corrosion of dissimilar materials. Nonisolated dissimilar materials with or without corrosion resistant finishes, where used either in contact with a transfer fluid, or without such contact, shall not be corroded to the extent that their function is or may be impaired under in-use conditions during their intended design lives. Dissimilar materials joined to form the transport system shall be electrically isolated from each other unless documentation is provided to demonstrate that the joints are sufficiently compatible to prevent corrosive wear and deterioration to the extent that their function would be impaired to a degree that would affect the performance as declared in disclosure statement form.

Subp. 3. Corrosion by leachable substances. Chemical substances that can be leached by moisture from any of the materials within the system shall not cause corrosive deterioration of any other components that may impair the ability of these components to perform their intended function as declared in disclosure statement form.

Subp. 4. Effects of decomposition products. Chemical decomposition products that are expelled from components under in-use conditions shall not cause the degradation of other components within the system to the extent that it would impair their ability to perform their intended functions to a degree that would affect the performance as declared in disclosure statement.

Statutory Authority: *MS s 216C.25*

1325.2100 EROSION, CORROSION.

The solar system and components shall not be adversely affected by erosive wear (such as by the flow of a liquid transfer medium) to an extent that will impair their functions during their intended design lives.

Statutory Authority: *MS s 216C.25*

1325.2200 HEAT OR HUMIDITY TRANSFER EFFECTS.

Heat or humidity transfer from the collector, thermal storage, piping, or other components of the solar system or subsystem shall not interfere with the efficient operation of the solar system or cause loss of control of temperature, humidity, or other controlled conditions.

Statutory Authority: *MS s 216C.25*

1325.2300 EFFECTS OF EXTERNAL ENVIRONMENT.

Subpart 1. **General.** The solar systems for heating (H) and combined heating and cooling (HC) and the hot water (HW) system/subsystem and their components shall not be affected by external environmental factors to an extent that will impair their performance as declared in disclosure statement form.

Subp. 2. **Solar degradation.** Components or materials that are exposed to sunlight shall not undergo changes in their properties during their design lives that would impair the function of the system to a degree that would affect the performance as declared in disclosure statement form. When components or materials are exposed to UV radiation in combination with an intermittent water spray at their maximum "no flow" temperature, there shall be no excessive deterioration such as cracking, crazing, embrittlement, etching, loss of adhesion, changes in permeability, loss in flexural strength, or any other changes that may affect the performance of the components in the system.

Subp. 3. **Soil corrosion.** Materials that are intended to be buried in soils shall not be degraded under in-use conditions to an extent that may impair their functions during their intended design lives.

Subp. 4. **Airborne pollutants.** Materials exposed under in-use conditions to airborne pollutants such as ozone, salt spray, sulfur dioxide, oxides of nitrogen and/or hydrogen chloride shall not be affected by those pollutants to an extent that may impair their functions during their intended design lives.

Subp. 5. **Growth of fungi.** Components and materials used in the solar systems shall not promote the growth of fungi, mold, or mildew.

Statutory Authority: *MS s 216C.25*

1325.2400 MAINTAINABILITY.

Subpart 1. **Accessibility for maintenance and servicing.** The solar system shall be designed, constructed, and installed to provide adequate access for general maintenance and convenient servicing.

Subp. 2. **Service personnel.** The solar systems shall be capable of being serviced by a trained service technician using a maintenance manual.

Subp. 3. **Replacement parts.** Parts, components, and equipment required for service, repair, or replacement shall be commercially available or available from the system or subsystem manufacturer or supplier.

Subp. 4. **Draining and filling of liquids.** To facilitate system or subsystem maintenance and repair, subsystems employing liquids shall be capable of being filled and drained.

Subp. 5. **Flushing of liquid subsystems.** Suitable connections shall be provided for the flushing (cleaning) of liquid energy systems and subsystems.

Subp. 6. **Installation, operation, and maintenance manual.** A manual shall be provided to the purchaser for the operation and maintenance of the solar energy system/subsystem. An installation manual shall be provided to the trained service technician for installation and repair of the solar energy system/subsystem.

Subp. 7. **Installation instructions.** The manual shall include physical, functional, and procedural instructions describing how the components of the solar energy system are to be installed. These instructions shall include descriptions of both interconnections among the system components and their connections with the facility and site.

Subp. 8. **Maintenance and operation instructions.** The manual shall completely describe the H, HC, and DHW systems, their breakdown into subsystems, their relationship to external systems and elements, their performance characteristics, and their required parts and procedures for meeting specified capabilities. The manual shall list all parts of the system, by subsystem, describing as necessary for clear understanding of operation, maintenance, repair, and replacement such characteristics as shapes, dimensions, materials, weights, functions, and performance characteristics. The manual shall include a tabulation of those specific performance requirements which are dependent upon specific maintenance procedures. The maintenance procedures, including ordinary, preventive, and minor repairs, shall be cross referenced for all subsystems and organized into a maintenance cycle. The manual shall fully describe operation procedures for all parts of the system including those required for implementation of specified planned changes in mode of operation. The manual shall include instructions for the inspection, treatment, and disposal of transfer fluids used in the system.

Subp. 9. **Maintenance plan.** The maintenance manual shall include a comprehensive plan for maintaining the specified performance of the solar system for its design life. The plan shall include all the necessary ordinary maintenance, preventive maintenance, minor repair work, and projections for equipment replacement.

Subp. 10. **Manual adjustment.** If manual control adjustments are required during normal operation of the system/subsystem, the operating instructions shall enumerate the time period over which these adjustments must be made and the environmental conditions requiring such adjustments.

Statutory Authority: *MS s 216C.25*

1325.2500 STANDARDS FOR EVALUATION OF SOLAR SUBSYSTEMS.

Parts 1325.2500 to 1325.2800 contain design criteria for evaluation of performance and quality of solar subsystems. Solar subsystems shall include but not be limited to the following: collector subsystems, energy transport subsystems, storage subsystems, and control subsystems.

Statutory Authority: *MS s 216C.25*

1325.2600 COLLECTOR SUBSYSTEMS.

Subpart 1. **Transmission losses due to outgassing.** Outgassing of volatiles that will reduce collector performance below specified design values shall not occur when the collector is exposed to the temperature and pressure that will occur in actual service.

Subp. 2. **Condensation.** Condensation formed on the underside of the cover plate(s) shall not reduce its transmittance during its design life to a degree that would affect the performance as declared in disclosure statement form.

Subp. 3. **Dirt retention.** The cover plate(s) under normal weather conditions shall not, with normal maintenance, collect or retain dirt to an extent that would reduce its ability to transmit sunlight to a degree that would affect the performance as declared in the disclosure statement form.

Subp. 4. **Damage by hail.** Refer to part 1325.1700, item C.

Statutory Authority: *MS s 216C.25*

1325.2700 TRANSPORT AND STORAGE SUBSYSTEMS.

Subpart 1. **Entrapped air.** When liquid heat transfer fluids are used, the system shall provide suitable means for air removal.

Subp. 2. Protection against blockage of fluid flow. The entire heat transport system shall be protected to prevent contamination by foreign substances that may impair the flow and quality of the heat transfer fluid to a degree that would affect the performance as declared in disclosure statement form. Dust and fan systems shall be protected against accumulations of deposits of dust, dirt, or fungi that reduce flow and efficiency.

Subp. 3. Automatic pressure and temperature relief valves for flammable or combustible fluids. The fluid transfer systems shall include a pressure relief valve. The valve and its discharge system shall not permit fluid discharge into occupied space. A holding tank shall be included in the system for collection of discharge expected from the relief valve. The pressure relief valve shall be designed based on maximum temperature criteria for abnormal operating conditions. ΔP must be limited to comply with temperature criteria. It shall prevent further increase in temperature and provide discharge in the same manner as the pressure relief valve. Maximum fluid temperature at which temperature relief valve shall operate: 37.8 degrees Celsius (100 degrees Fahrenheit) below firepoint of fluid.

Subp. 4. Detection of highly toxic and flammable fluids. If heat transfer fluids that are highly toxic and/or flammable are used, means shall be provided for the detection of leaks and the warning of occupants when leaks occur.

Subp. 5. System drainage. System designs incorporating automatic drainage of heat transfer fluid or storage to prevent freezing of the fluid in solar collectors shall not be constructed of materials which corrode in the presence of air or shall be suitably protected against such corrosion. Liquid systems, system components, piping, or storage tanks shall be designed for complete isolation and drainage for maintenance purposes.

Subp. 6. Heat transfer fluids. The heat transfer fluid shall not cause deleterious effects to those parts of the solar energy system with which it comes into contact. Except when such changes are allowed by the design of the system, the heat transfer fluid shall not freeze, give rise to excessive precipitation, otherwise lose its homogeneity, boil, change pH, or undergo large changes in viscosity when exposed to its intended service temperature and pressure range.

Subp. 7. Contamination. Thermal transfer system and storage materials, including any interior protective coatings and the heat storage medium used, shall not contaminate potable water nor ventilation air.

Statutory Authority: *MS s 216C.25*

1325.2800 CONTROL SUBSYSTEMS.

The control subsystem shall provide for the safe and efficient operation of the solar systems/subsystems. The solar energy system controls shall prevent major damage to system components in the event of power failure or other system malfunction. Main shutoff valves and switches shall be conspicuously marked and placed in readily accessible locations. The control subsystem shall include such provision for manual bypass, adjustment, or override of automatic controls as is required to facilitate installation, start-up, shut-down, and maintenance.

Statutory Authority: *MS s 216C.25*

1325.2900 REFERENCE STANDARDS AND TEST METHODOLOGY.

Subpart 1. Standards listed. The following standards have been excerpted from the documents referenced below. Use of these standards and tests is mandatory for evaluation of systems, subsystems, and components.

A. ASTM American Society for Testing and Materials, 1916 Race Street, Philadelphia, Pennsylvania 19103.

B. HUD NBSIR 76-1059 Intermediate Minimum Property Standards for Solar Heating and Domestic Hot Water Systems, April, 1976, 415 7th Street SW, Washington, D.C. 20410.

C. NASA 98M 10001 Interim Performance Criteria for Commercial Solar Heating and Combined Heating/Cooling Systems and Facilities, February 28, 1975 National Aeronautics & Space Administration, Solar Heating & Cooling Office, Marshall Space Flight Center, Huntsville, Alabama 35812.

D. NBS Interim Performance Criteria for Solar Heating and Combined Heating/Cooling Systems and Dwellings, January 1, 1975, U.S. Department of Commerce, Washington, D.C. 20234.

E. ASHRAE 93-77, Methods of Testing to Determine the Thermal Performance of Solar Collectors, ASHRAE Circulation Sales Department, 345 E 47th Street, New York, New York 10017.

Subp. 2. **Materials compatibility, solar systems.** Effects of decomposition products — NASA Chapter 5, Section 15.

Material compatibility test — NASA Chapter 5, Section 13.

Absorptive coatings, compatibility with heat transfer medium ASTM D-1308-57, 1973.

Transport subsystem, materials used for transporting fluids — HUD Appendix Table B-2. Materials/transfer fluid compatibility — ASTM D 2570-73 NBS Appendix Section 12.

Gaskets and sealants, chemical and physical compatibility — ASTM F82-67, 1973, Deterioration of gaskets and sealants — NASA Chapter 5, Section 10.

Subp. 3. **Effects of external environment, solar systems.** Growth of fungi, mold, or mildew Section 10, UL 181-74 Method 508 MIL-STD-810.

Solar degradation — NASA Chapter 5, Sections 01, 02, 03.

Soil corrosion — NASA Chapter 5, Section 04.

Airborne pollutants — NASA Chapter 5, Section 5.

Collector subsystem Cover plate, UV stability — ASTM E-424-71 Absorber plate, UV stability — ASTM D822-60, 1973 (modification of above) HUD 515 2.4.3 Moisture stability — ASTM D2247-68, 1973.

Organic coupling hoses UV stability — ASTM D750-68, 1974 Compatibility with heat transfer fluid — ASTM F82-67, 1973 Ozone degradation — ASTM D1149-64, 1970.

Subp. 4. **Temperature and pressure resistance, solar systems.** Thermal cycling stresses — NBS Appendix, Section 08.

Thermal degradation test — NASA Chapter 5, Appendix, Section 06.

Leakage — NBS Appendix, Section 09.

Absorptive coatings, thermal stability ASTM D660-44, 1970; D661-44, 1975; D714-56, 1974; D772-47, 1975.

Gaskets and sealing pressurized systems test — ASTM D1081-60, 1974.

Subp. 5. **Collector subsystems.** Collector thermal performance test — NBSIR 74-635. Durability and reliability of collector subsystems: outgassing, transmission losses due to — NASA Chapter 5, Section 11.

Durability/reliability of transport subsystems: deterioration of heat transfer fluids — NBS Appendix, Section 07.

Statutory Authority: *MS s 216C.25*

1325.3000 EXPLANATION OF SYMBOLS FOR CALCULATIONS.

Subpart 1. Table of symbols.

A_c	Collector aperture area (ft ²)(M ²)
(m_{c_p})	Min fluid capacitance (Btu/h°F)(Watts/°C)
c_p	Fluid capacitance (Btu/(lb°F))(Joules/Kg - °C)
D_1, D_2	Dimensionless parameters
Δt_d	Temperature difference for building design temperature conditions (°F)
Δt	Total number of hours in a particular month (h)

ϵ_c	Effectiveness of the collector-storage heat exchanger
ϵ_L	Effectiveness of the load heat exchanger
θ	Collector tilt ($^\circ$)
E	Solar energy supplied for a particular month (Btu/month)(Joule/month)
E_{total}	Solar energy supplied for an entire year (Btu/year)(Joules/year)
f	Monthly fraction of total heating load supplied by solar energy
F_{annual}	Yearly fraction of the total heating load supplied by solar energy
F_R	Collector heat removal factor
F_R'	Combined form of the collector heat exchanger effectiveness and the collector heat removal factor (F_R)
γ	Solar collector azimuth angle (for due south = 180°)
\bar{I}_H	Monthly average of the daily radiation incident on a horizontal surface (Btu/(day - ft ²)) (Joule/Day - M ²)
\bar{I}_T	Monthly average of the daily radiation incident on a tilted surface (Btu/(day - ft ²)) (Joule/Day - M ²)
\bar{K}_1	Ratio of the monthly averages of the daily radiation on a horizontal surface to the extraterrestrial radiation on a horizontal surface
K_1	Correction factor to correct f for various storage capacities other than 15 Btu/($^\circ\text{F}$ - ft ²)(306,620 Joule/ $^\circ\text{C}$ - M ²)
K_2	Correction factor to correct for $L_1(mc_p)$ min/UA other than 2
L	Total heating and hot water load for a particular month (Btu/month)(Joules/month)
L_{Total}	Total heating and hot water load for an entire year (Btu/year)(Joules/year)
m	Mass of domestic hot water used for a particular month (lb)(kg)
\dot{m}	Flow rate of the working fluid either air or liquid (lb/hr)(kg/hr)
M	Mass of thermal storage (lb)(kg)
N	Number of days in a particular month
ϕ	Latitude
Q_s	Space heating load for a particular month (Btu/month)(Joules/month)
Q_w	Domestic hot water heating load for a particular month (Btu/month)(Joules/month)
q_d	Building design rate of sensible heat loss (Btu/h)(Watts)
\bar{R}	Ratio of the monthly average daily radiation on a tilted surface to that on a horizontal surface

S	Monthly incident solar radiation on a tilted surface Btu/(Month - ft ²) (Joules/month - M ²)
—	
t _a	Average ambient air temperature for the particular month
t _s	Temperature of domestic hot water supply (°F)(°C)
t _m	Temperature of water main supply (°F)(°C)
t _{ref}	Reference temperature, 212°F (100°C)
Δtime	Total number of hours in each month
—	
γa	Average transmissivity-absorptivity product for design purposes
(γa) _n	Transmissivity-absorptivity product at normal incidence
U _L	Collector heat loss factor (Btu/hr - °F - ft ²) (Watt/°C - M ²)
UA	Building heat loss factor Btu/(h - °F)(Watt/°C)
f _n	Monthly fraction of heating load supplied by solar energy
f _c	Monthly fraction of cooling load supplied by solar energy
f _o	Monthly fraction of other load supplied by solar energy
P.F.	Proportionality factor used to refine heat load calculations based on the 65° degree-day method

Subp. 2. References cited. References cited:

A. Klein, S. A., Beckman, W. A., and Duffie, J. A. "Design Procedure for Solar Heating Systems," presented at the 1975 International Solar Energy Congress, UCLA, Los Angeles, California, July, 1975;

B. B. Y. H. Liu, R. C. Jordan, "Availability of Solar Energy for Flat Plate Solar Heat Collectors," Low Temperature Engineering Application of Solar Energy, ASHRAE, New York, 1967.

Statutory Authority: *MS s 216C.25*

1325.3100 CALCULATION PROCEDURES FOR SOLAR SYSTEMS.

Subpart 1. Outline. Performance measurements for a solar system shall be made using the following outline:

- A. Calculate the monthly energy load (heating, cooling).
- B. Calculate the monthly incident solar radiation on the collector array.
- C. Determine the component parameters, i.e., subsystem efficiencies, capacities, required operating energies, etc.
- D. Calculate the monthly fraction of load supplied by solar system.
- E. With the monthly loads and monthly fractions supplied by solar, calculate the annual fraction of load supplied by solar energy less solar system operating energy.

Subp. 2. References for procedures. Klein, S.A., Beckman, W.A., and Duffie, J.A., "Design Procedure for Solar Heating Systems," presented at the 1975 International Solar Energy Congress, UCLA, Los Angeles, California, July, 1975.

Statutory Authority: *MS s 216C.25*

1325.3200 MEASUREMENTS FOR SPECIFIC SYSTEMS.

Subpart 1. Requirement. Specifically, performance measurements for different solar systems shall be made as follows.

Subp. 2. **Combined collector and storage devices.** The system thermal performance is determined by the short-term (one to three days) collection and storage of thermal energy obtained from solar radiation and the amount of useful energy delivered to the load from storage for part and full load conditions. Experimental performance data, in terms of heat collected and stored or delivered to load, shall be provided for the design conditions including solar power density, heat transfer fluid temperature, ambient temperature, wind, solar radiation incident angle, and flow rates. The daily and average test period electrical operating requirements shall be reported with system performance.

Subp. 3. **Passive (integral) solar systems.** The thermal performance of an integral solar system shall be obtained from a detailed simulation analysis of the climate, building thermal properties, and occupancy thermal influence.

Subp. 4. **Active solar systems.** Where applicable, collector based solar systems shall use the calculation procedures outlined in part 1325.3300. When different procedures are used due to an incompatibility between the system (or subsystem) under study and the outlined procedures, the elected calculation procedure shall be representative of realistic demand, solar radiation, component capacities, efficiencies, required operating energies, etc.

Statutory Authority: *MS s 216C.25*

1325.3300 DETERMINING MONTHLY LOAD.

Subpart 1. **Monthly load defined.** The monthly load is comprised of heating, cooling, and other service loads that might be offset by the solar system.

Subp. 2. **Total heating load.** The total heating load is determined on a monthly basis for both space and hot water heating. The space and hot water heating loads are calculated separately and for combined systems, the monthly individual loads are added to get a monthly total load.

Subp. 3. **Hot water load.** Determine the required volume of domestic hot water (gal) required on a monthly basis. Then, knowing the volume, calculate the mass (m) using a value of 8.33 lb/gal (119.8 kg/M³). Determine the water main temperature (t_m) or assume t_m = 55 degrees Fahrenheit (12.8 degrees Celsius). Calculate the monthly domestic hot water heating load using the following equation:

$$Q_w = \left[\frac{\text{(lb or kg)}}{\text{DHW consumed}} \right] \left[\frac{\text{Specific Heat of Water}}{\text{(Month)}} \right] \left[\frac{\text{Joule}}{\text{(kg-}^\circ\text{C)}} \right] \left[\text{Temp. Supply} - \text{Temp. Water Main} \right]$$

For situations where the domestic hot water requirements cannot be reasonably estimated, a load of 1.6 x 10⁶ Btu/month may be assumed for a typical residence. This is equivalent to approximately 90 gallons of hot water use per day.

Subp. 4. **Space heating load.** The space heating load for each month shall be calculated using the degree day method. A P.F. value of 0.75 shall be used unless practical experience in the locality dictates the use of a different value.

To calculate space heating load:

A. Building heat loss shall be calculated according to methods described in the ASHRAE Handbook of Fundamentals or other recognized means. The loss calculations shall include:

Heat loss by transmission:

$$Q_{st} U A (t_i - t_o)$$

Heat loss by infiltration - use air change method, or crack method.

$$\text{In either case, } Q_{si} = .018 V (t_i - t_o)$$

B. Obtain the monthly total degree days from the ASHRAE Systems Handbook for the particular location for each month.

C. Add infiltration and transmission losses to obtain design total instantaneous loss. $Q_s = Q_{st} + Q_{si}$

D. Obtain Btu's per degree day for month.

$$P.F. \times Q_s \times 24 = \text{Btu/DD}$$

$$t_i - t_o$$

Q_s = Heat flow rate, Btu/Hr.

U = Heat transfer coefficient, Btu/(hr) (ft²) (F°)

A = Area of transfer surface, ft²

t_i = Design indoor temperature, °F

t_o = Design outdoor temperature

P.F. = Proportionality factor

V = Volume of air (c.f. per hour)

D.D. = Degree day

Subp. 5. **Calculation of cooling and other loads.** Calculations of cooling loads and/or other loads that might be offset by the solar system shall be according to the ASHRAE Handbook of Fundamentals or other recognized means.

Subp. 6. **Domestic hot water load.** Part 1325.9000 is included for tabulating loads.

Statutory Authority: *MS s 216C.25*

1325.3400 DETERMINING THE MONTHLY INCIDENT SOLAR RADIATION.

Part 1325.9100 is included for tabulating the incident solar radiation calculation.

Monthly average of the daily radiation incident on a horizontal surface I_H . For locations near Saint Cloud, I_H shall be taken from part 1325.9200.

For other locations, alternate means of determining I_H , such as interpolation from radiation maps, may be used.

Ratio of the monthly averages of the daily radiation on a horizontal surface to the extraterrestrial radiation, (K_i): for locations near Saint Cloud, K_i shall be taken from part 1325.9200. For other locations, alternate means may be used. (Donald G. Baker and John C. Klink, "Solar Radiation Reception, Probabilities and Areal Distribution in the North Central Region," Agricultural Experiment Station, University of Minnesota, Technical Bulletin 300 (1975); Donald G. Baker, "Climate of Minnesota," Part VI: Solar Radiation at St. Paul, Agricultural Experiment Station, University of Minnesota, Technical Bulletin 280 (1971).)

Ratio of the monthly average daily radiation on a tilted surface to that on a horizontal surface for collectors facing due south (R): using part 1325.9300 and knowing collector tilt (Θ), latitude (ϕ), and K_i , determine R for each month. K_i may be interpolated.

Monthly average daily radiation on a tilted surface, (I_T): Knowing I_H and R for each month, calculate I_T on a monthly basis using the equation: $I_T = (I_H)(R)$

Total monthly average daily radiation on a tilted surface, (S): (I_T), the monthly average daily radiation on a tilted surface, must be multiplied by the total days in each month, (N) to obtain total insolation for each month.

$$S = (I_T)(N).$$

Shading should not be neglected in calculating the incident solar radiation on a particular collector array. The amount of shading is strongly dependent on the collector site and orientation; thus, each case must be analyzed separately.

Statutory Authority: *MS s 216C.25*

1325.3500 PREDICTING SYSTEM PERFORMANCE.

Subpart 1. How procedure applies. This procedure does not apply to passive systems or to active systems that do not generally conform to the configuration of part 1325.9400, subpart 1 or 2 as appropriate. The procedure cannot be used for systems in latitudes farther north than 60 degrees. The procedure is intended to evaluate long-term performance of most solar heating systems using a simple desk calculator or slide rule. Since in most instances flat plate collectors are utilized for heating buildings, the collector component parameters are only valid for modeling flat plate collectors. Concentrating collectors or evacuated tubular collectors cannot be incorporated into the solar heating system evaluation as it is presently written in parts 1325.3100 to 1325.3600. The system evaluation procedure as outlined in parts 1325.3100 to 1325.3600 can only accurately predict system performance for systems using south facing collector arrays. Cases of different collector orientations must be analyzed using a different procedure.

Subp. 2. Component parameters. The component parameters characterize the various components that make up the system. In cases of design where several different solar heating systems may be considered for the same location and collector tilt, incident radiation on a tilted surface (I_T) need only be calculated once. In such a case, only the values of the component parameters need to be adjusted for the different systems.

Subp. 3. Solar collector. Using collector thermal performance efficiency curves provided by the manufacturer (as determined by test in accordance with NBSIR 74-635) range of operational temperature, insolation, tilt angles, and flow rates determine the collector parameters $F_R U_L$ and $F_R(\tau\alpha)$. The thermal efficiency collector curve must be plotted such that the y axis is the thermal efficiency (η) and the x axis, the temperature difference between the collector fluid inlet and the ambient air divided by the incident solar radiation ($t_i - t_a/I_T$). The thermal efficiency is the ratio of useful output thermal energy to the incident solar energy on the collector aperture area. To determine $F_R U_L$ calculate the slope of a linear curve fit for the efficiency curve. The y axis intercept is equal to $F_R(\tau\alpha)$.

Subp. 4. Collector storage heat exchanger. To simplify the number of input parameters, the collector storage heat exchanger effectiveness ϵ_c and the collector heat removal factor, F_R , can be combined in a single parameter F_R' . Determine F_R'/F_R by the following equation, or the graphical representation in part 1325.9400, subpart 3.

$$\frac{F_R'}{F_R} = \frac{1}{1 + \frac{F_R U_L A_c}{(m c_p)_c} \left[\frac{(m c_p)_c}{\epsilon_c (m c_p)_{\min}} - 1 \right]}$$

where A_c = aperture area of the collector array.

$(m c_p)_{\min}$ = minimum fluid capacitance rate of the working fluids across the collector storage heat exchanger.

$(m c_p)_c$ = fluid capacitance rate of the collector working fluid.

ϵ_c = effectiveness of the collector heat exchanger.

$$= \frac{\text{actual heat transfer}}{\text{maximum possible heat transfer}}$$

The water to water collector storage heat exchanger effectiveness (ϵ_c) is easily calculated from methods given in the ASHRAE Handbook of Fundamentals or from data supplied by the manufacturer.

Note: In systems that do not use a collector to storage heat exchanger, the ratio of F_R' to F_R is equal to one.

$$\frac{F_R'}{F_R} = 1$$

Subp. 5. **Storage.** In general for solar heating systems utilizing water or air as heat transfer fluids an average storage capacity of 15 Btu/degrees Fahrenheit per square foot of collector has been determined as near economic optimum. For storage capacities other than 15 a correction factor will be introduced later to correct the value of the predicted system thermal performance.

Subp. 6. **Load heat exchanger.** Determining from the manufacturer's specifications the load heat exchanger effectiveness (ϵ_L) and calculate minimum fluid capacitance (mc_p)_{min} rate across the exchanger. Where ϵ_L is not provided, values can be determined using procedures in the ASHRAE Handbook of Fundamentals.

Note: Since a load heat exchanger is not usually incorporated into a system using air collectors and air as the transport medium, the load heat exchanger effectiveness may be assumed equal to one.

Subp. 7. **Dimensionless parameters (D_1 , D_2).** The dimensionless parameters D_1 and D_2 characterize the entire solar heating system thermal effectiveness. Calculate the two dimensionless parameters for each month using the factors defined previously on a monthly basis according to the following equations:

$$D_1 = \frac{\text{energy absorbed by collector plate}}{\text{total heating load}}$$

$$= [A_c] \left[\left[F_R (a)_n \right] \left[\left(\frac{\overline{\tau a}}{\tau a} \right)_n \right] \left[\frac{F_R}{F_R} \right] \right] \frac{S}{L}$$

$$D_2 = \frac{\text{ref. collector plate energy losses}}{\text{total heating load}}$$

$$= [A_c] \left[F_R U_L \right] \left[\frac{F_R}{F_R} \right] \left[t_{\text{ref}} - \overline{t}_a \right] \frac{\Delta \text{ time}}{L}$$

$$t_{\text{ref}} = 212^\circ\text{F (arbitrarily chosen reference temperature)}$$

$$\overline{t}_a = \text{average ambient air temperature for the particular month.}$$

$$\Delta \text{ time} = \text{total number of hours in each month}$$

$$\left[\left(\frac{\overline{\tau a}}{\tau a} \right)_n \right] = 0.90 \text{ to account for the change in the value of the effective transmission-absorption product with incident angle throughout a day.}$$

Subp. 8. **Monthly fraction of total heating load supplied by solar energy (f_n).** The fraction of the heating load supplied by solar energy (f_n) can be determined from Figure as a function of the dimensionless parameters, D_1 and D_2 . Locate the two dimensionless parameters on part 1325.9400, subparts 4 and 5 and determine the fraction of total heating load supplied by solar energy (f_n) on a monthly basis.

Statutory Authority: *MS s 216C.25*

1325.3600 ANNUAL FRACTION OF THE TOTAL HEATING LOAD SUPPLIED BY SOLAR ENERGY (F_{ANNUAL}).

Subpart 1. **General.** It was mentioned earlier that the procedure was intended to only provide an estimate of system performance for a particular month but a relatively good estimate for long-term performance (yearly basis). In order to

calculate f on a yearly basis, the following calculations must be performed. Part 1325.9500 has been included for tabulating and calculating f on a yearly basis.

Subp. 2. **Solar energy supplied.** The actual solar energy supplied for each month must be calculated as follows:

$$\begin{aligned} E_{Jan} &= f_{Jan} L_{Jan} \\ E_{Feb} &= f_{Feb} L_{Feb} \\ E_{Dec} &= f_{Dec} L_{Dec} \end{aligned}$$

Total the solar energy supplied for the entire year by summing the contributions from each month.

$$E_{Total} = E_{Jan} + E_{Feb} + E_{Dec}$$

Subp. 3. **Required operating energy.** Calculate the amount of operating energy required by the solar system, using standard engineering methods.

Subp. 4. **Yearly heating load.** Calculate the total heating load for the entire year (L_{Total})

Subp. 5. **Determining F_{annual} .** Knowing the total annual solar energy supplied by the heating system (E_{Total}) and the total annual heating load (L_{Total}), determine F_{annual} for the entire year from the following equation:

$$F_{annual} = \frac{E_{total} - \text{operating energy}}{L_{total}}$$

Subp. 6. **Correction factors.** Correction factors for F_{annual} :

A. To correct for various storage capacities other than 15 Btu/degrees Fahrenheit · ft², use part 1325.9400, subpart 6 to obtain the correction factor (K_1).

B. For cases where $L(mc_p)_{min}/UA$ is other than 2, use the figure in part 1325.9400, subpart 7 to obtain the correction factor (K_2).

C. Utilizing the correction factors K_1 and K_2 , the corrected and final value of F_{annual} may be calculated as follows:

$$F'_{annual} = (K_1)(K_2)F_{annual}$$

Subp. 7. **Calculation of fraction of cooling and other loads supplied by solar energy (f_c), (f_o).** Calculation of cooling and other solar contribution shall be determined in a manner similar to the process described for calculation of heating contribution.

Calculate cooling and/or other loads.

Apply the following parameters in the same manner as in subparts 5 and 6: monthly incident solar radiation; component parameters.

Calculate the monthly fraction of load (less operating energy) supplied by solar system.

Calculate the annual fraction of load supplied by solar energy. Calculations shall be performed with the same degree of accuracy and with the same completeness as those for determining solar heating contribution. Tables similar to parts 1325.9000, 1325.9100, and 1325.9500 may be used for data presentation.

Statutory Authority: MS s 216C.25

1325.9000 TABLE FOR CALCULATING LOADS.

SPACE HEATING LOAD		HEATING LOAD		TOTAL HEATING LOAD	
DEGREE DAYS	BTU MONTH Qs	DHW MONTH m* Cal/lbm	BTU MONTH Qw	BTU MONTH L = Qs + Qw	T _a (°F) Ambient Air Temperature
Jan.					
Feb.					
Mar.					
April					
May					
June					
July					
Aug.					
Sept.					
Oct.					
Nov.					
Dec.					

*1 gal = 8.3 lbm
 t_s = _____ °F
 t_m = _____ °F

q_d = _____ BTU/h
 ΔT_d = _____ (°F)
 UA = _____ BTU/h °F

1325.9100 TABLE FOR TABULATING INCIDENT SOLAR RADIATION CALCULATION.

Component Parameters

I.	<u>Collectors</u>	$FR_{UL} =$	$m =$
		$FR(\tau\alpha)_n =$	$c_p =$
II.	<u>Collector-Storage Heat Exchanger</u>	$FR'/FR =$	$\frac{(FR_{UL})A_c}{(m c_p)c} =$
		$\epsilon_c =$	$\frac{(m c_p)c}{\epsilon_c(m c_p)\text{min}} =$
III.	<u>Storage</u>	$M =$	$c_p M/A_c =$
IV.	<u>Load Heat Exchanger</u>	$\frac{\epsilon_L}{\epsilon_L} =$	$\frac{\epsilon_L(m c_p)\text{min}}{UA} =$
			$(m c_p)\text{min} =$

latitude = —

tilt = —

Incident Solar Radiation

	BTU Day ft ² I _H	K _t	R	BTU Day ft ² I _T = I _{HR}	BTU Month ft ² S
Jan.					
Feb.					
Mar.					
April					
May					
June					
July					
Aug.					
Sept.					
Oct.					
Nov.					
Dec.					

Statutory Authority: MS s 216C.25

MINNESOTA RULES 1989

1325.9200 MONTHLY AVERAGES OF DAILY RADIATION.

St. Cloud, MN Lat. 45° 35' N El. 1034 ft.

	I_H	K_t	t_q
January	632.8	0.595	13.6
February	976.7	0.629	16.9
March	1383	0.614	29.8
April	1598.1	0.534	46.2
May	1859.4	0.530	58.8
June	2003.3	0.533	68.5
July	2087.8	0.573	74.4
August	1828.4	0.570	71.9
September	1369.4	0.539	62.5
October	890.4	0.490	50.2
November	545.4	0.435	32.1
December	483.1	0.504	18.3

Values from "A Rational Procedure for Predicting a Long Term Average Performance of Flat Plate Collectors." Solar Energy, 17, No. 2, 1963. B.Y.H. Liu, R.C. Jordan.

Statutory Authority: *MS s 216C.25*

1325.9300 RATIO OF AVERAGE DAILY RADIATION ON TILTED SURFACE TO THAT ON HORIZONTAL SURFACE.

R for $K_T = .40$

Latitude	(Latitude - Tilt) = 15.0			(Latitude - Tilt) = .0		
	40	45	50	40	45	50
January	1.44	1.68	1.90	1.61	1.88	2.13
February	1.35	1.40	1.58	1.45	1.49	1.69
March	1.17	1.24	1.32	1.19	1.26	1.35
April	1.06	1.09	1.12	1.03	1.05	1.08
May	.99	1.00	1.01	.93	.93	.94
June	.97	.97	.97	.89	.89	.88
July	.98	.98	.99	.91	.91	.90
August	1.03	1.05	1.06	.98	.99	1.01
September	1.12	1.17	1.23	1.12	1.16	1.22
October	1.27	1.39	1.46	1.34	1.47	1.54
November	1.39	1.58	1.92	1.53	1.75	2.14
December	1.51	1.85	2.11	1.70	2.12	2.40

Latitude	(Latitude - Tilt) = -15.0			Vertical		
	40	45	50	40	45	50
January	1.68	1.98	2.24	1.51	1.84	2.13
February	1.48	1.51	1.72	1.25	1.30	1.54
March	1.15	1.22	1.30	.86	.96	1.08
April	.95	.96	.99	.61	.67	.74
May	.83	.83	.83	.48	.53	.58
June	.78	.77	.76	.44	.48	.52
July	.80	.80	.79	.46	.50	.54
August	.89	.90	.91	.55	.60	.66
September	1.06	1.10	1.16	.75	.83	.93
October	1.34	1.47	1.53	1.08	1.25	1.34

MINNESOTA RULES 1989

1325.9300 ENERGY

194

November	1.58	1.82	2.24	1.39	1.66	2.12
December	1.80	2.27	2.56	1.65	2.17	2.47

R for $K_T = .50$

Latitude	(Latitude - Tilt) = 15.0			(Latitude - Tilt) = .0		
	40	45	50	40	45	50
January	2.53	1.80	2.06	1.72	2.05	2.34
February	1.40	1.47	1.68	1.53	1.59	1.83
March	1.20	1.28	1.38	1.24	1.32	1.42
April	1.08	1.11	1.14	1.04	1.07	1.10
May	1.00	1.08	1.02	.93	.93	.94
June	.97	.97	.97	.88	.88	.88
July	.98	.98	.99	.90	.90	.91
August	1.04	1.06	1.08	.99	1.01	1.03
September	1.14	1.20	1.27	1.15	1.20	1.28
October	1.32	1.45	1.54	1.41	1.56	1.64
November	1.46	1.69	2.08	1.63	1.89	2.35
December	1.60	1.99	2.30	1.83	2.31	2.65

Latitude	(Latitude - Tilt) = -15.0			Vertical		
	40	45	50	40	45	50
January	1.82	2.18	2.48	1.66	2.05	2.37
February	1.58	1.62	1.87	1.35	1.42	1.70
March	1.20	1.28	1.38	.90	1.01	1.16
April	.96	.98	1.01	.61	.68	.76
May	.82	.83	.83	.46	.52	.57
June	.77	.76	.76	.41	.45	.50
July	.79	.79	.79	.43	.48	.53
August	.90	.91	.93	.54	.60	.67
September	1.10	1.15	1.21	.77	.86	.97
October	1.42	1.57	1.65	1.16	1.35	1.46
November	1.71	1.99	2.48	1.51	1.83	2.37
December	1.96	2.50	2.84	1.83	2.42	2.77

R for $K_T = .60$

Latitude	(Latitude - Tilt) = 15.0			(Latitude - Tilt) = .0		
	40	45	50	40	45	50
January	1.60	1.92	2.22	1.84	2.21	2.54
February	1.46	1.54	1.79	1.61	1.69	1.96
March	1.23	1.32	1.44	1.28	1.37	1.50
April	1.09	1.12	1.17	1.06	1.09	1.13
May	1.00	1.01	1.03	.93	.94	.95
June	.96	.97	.97	.88	.88	.88
July	.98	.99	.99	.90	.90	.91
August	1.05	1.07	1.10	1.00	1.02	1.05
September	1.17	1.23	1.32	1.18	1.25	1.33
October	1.37	1.52	1.63	1.47	1.65	1.75

MINNESOTA RULES 1989

195

ENERGY 1325.9300

November	1.53	1.79	2.24	1.73	2.03	2.55
December	1.68	2.13	2.49	1.96	2.50	2.90

(Latitude - Tilt) = -15.0

Vertical

Latitude	40	45	50	40	45	50
January	1.96	2.37	2.71	1.81	2.26	2.62
February	1.68	1.73	2.07	1.45	1.53	1.85
March	1.25	1.34	1.46	.94	1.07	1.23
April	.98	1.01	1.04	.61	.69	.78
May	.82	.83	.83	.44	.50	.56
June	.76	.75	.75	.38	.43	
July	.78	.78	.79	.40	.46	.52
August	.90	.92	.94	.53	.60	.67
September	1.13	1.19	1.27	.79	.90	1.02
October	1.50	1.68	1.77	1.23	1.45	1.58
November	1.83	2.16	2.72	1.64	2.01	2.61
December	2.12	2.73	3.13	2.00	2.66	3.07

R for $K_T = .70$

(Latitude - Tilt) = 15.0

(Latitude - Tilt) = .0

Latitude	40	45	50	40	45	50
January	1.66	2.01	2.34	1.92	2.34	2.70
February	1.50	1.60	1.87	1.68	1.76	2.07
March	1.26	1.36	1.49	1.31	1.42	1.55
April	1.10	1.14	1.19	1.07	1.11	1.16
May	1.00	1.02	1.03	.93	.94	.95
June	.96	.97	.97	.57	.67	.68
July	.98	.99	1.00	.89	.90	.91
August	1.05	1.08	1.11	1.00	1.03	1.06
September	1.19	1.26	1.35	1.21	1.28	1.37
October	1.40	1.57	1.69	1.52	1.71	1.83
November	1.58	1.87	2.36	1.80	2.14	2.71
December	1.75	2.23	2.63	2.06	2.65	3.09

(Latitude - Tilt) = -15.0

Vertical

Latitude	40	45	50	40	45	50
January	2.07	2.52	2.89	1.92	2.42	2.81
February	1.75	1.82	2.14	1.52	1.61	1.96
March	1.29	1.39	1.53	.97	1.11	1.29
April	.99	1.02	1.07	.61	.70	.79
May	.81	.83	.84	.42	.49	.55
June	.75	.75	.75	.36	.41	.47
July	.78	.78	.79	.39	.45	.51
August	.91	.93	.96	.52	.59	.68
September	1.16	1.23	1.32	.81	.93	1.06
October	1.56	1.75	1.87	1.29	1.53	1.47
November	1.92	2.28	2.90	1.74	2.14	2.80
December	2.25	2.90	3.35	2.13	2.85	3.30

Statutory Authority: MS S 216C.25

1325.9400 ENERGY

1325.9400 FIGURES.

Subpart 1. Liquid system.

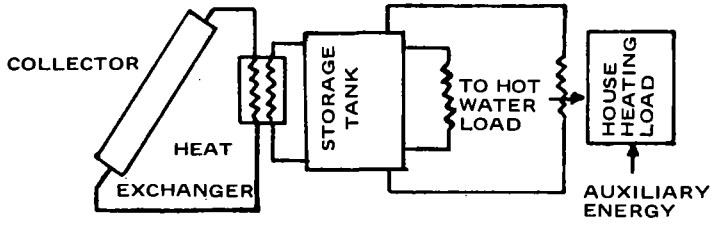

Subp. 2. Air system.

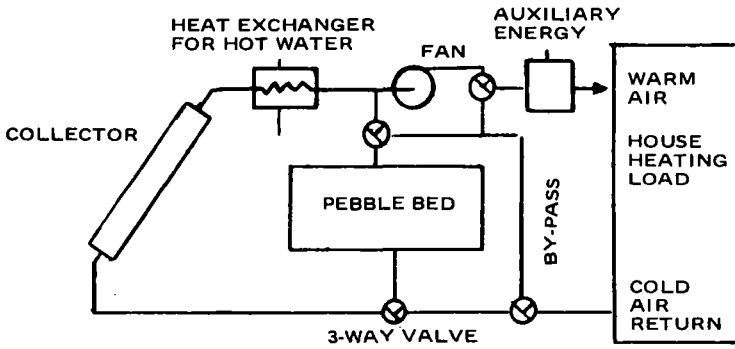

Subp. 3. Fluid capacitance ratios.

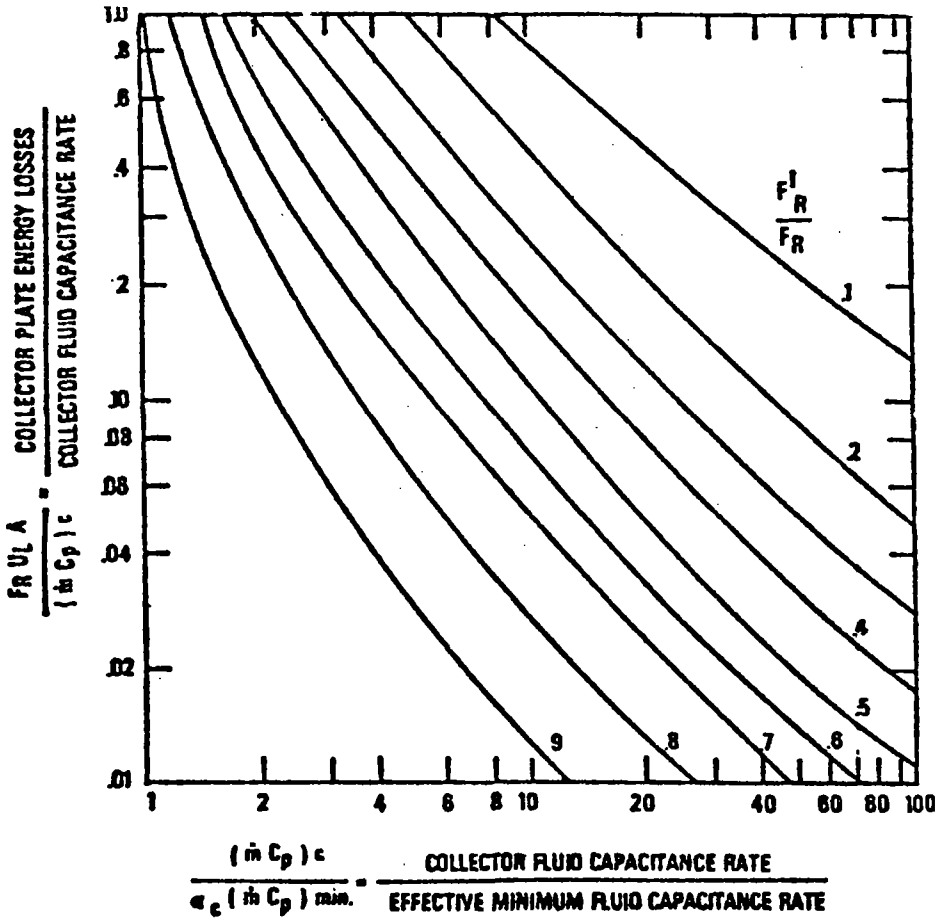

F_R' / F_R as a function of $F_R U_L A / (\dot{m} C_p)_c$ and $(\dot{m} C_p)_c / \epsilon_L (\dot{m} E_p)_{min}$.

Subp. 4. Liquid systems; relationship between solar fraction and dimensionless parameters.

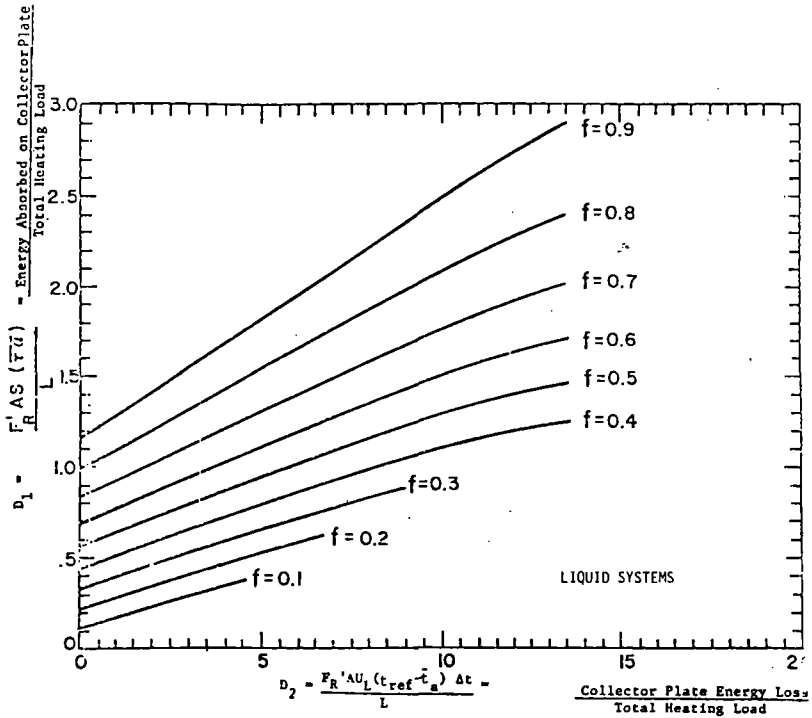

(Liquid systems) Relationship between solar fraction and dimensionless parameters D_1 and D_2 .

Subp. 5. Air systems; relationship between solar fraction and dimensionless parameters.

$$D_1 = \frac{F'_R AS (\overline{\tau\alpha})}{L} = \frac{\text{Energy Absorbed on Collector Plate}}{\text{Total Heating Load}}$$

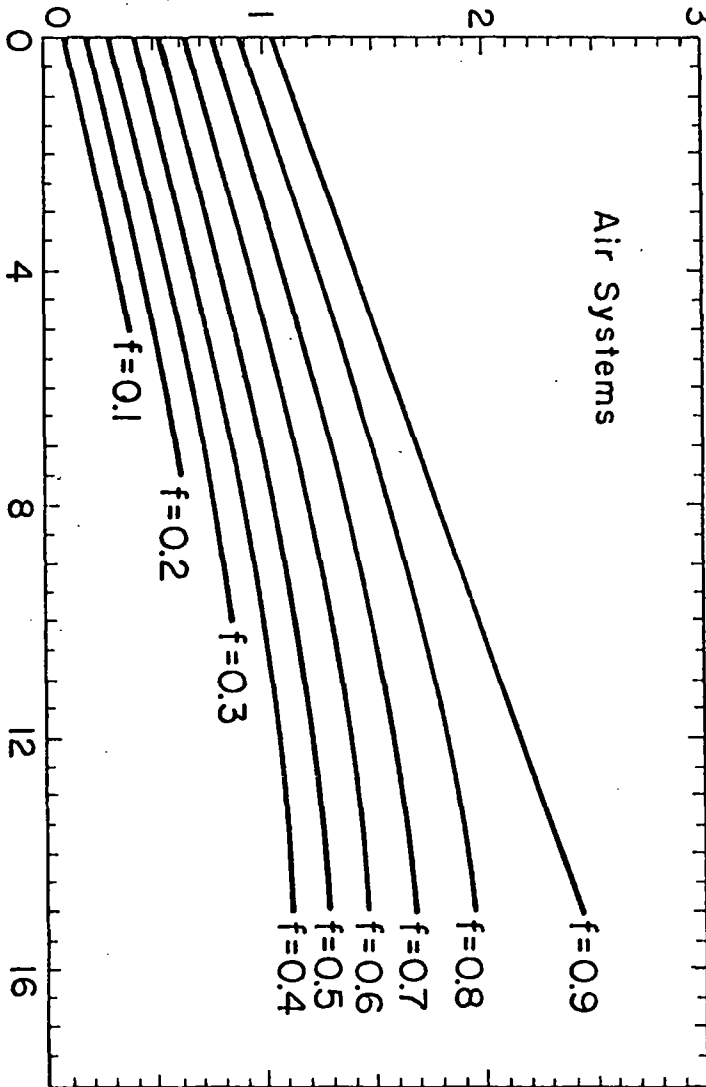

(Air Systems) Relationship between solar fraction and dimensionless parameters D_1 and D_2 .

Subp. 6. Correction factor.

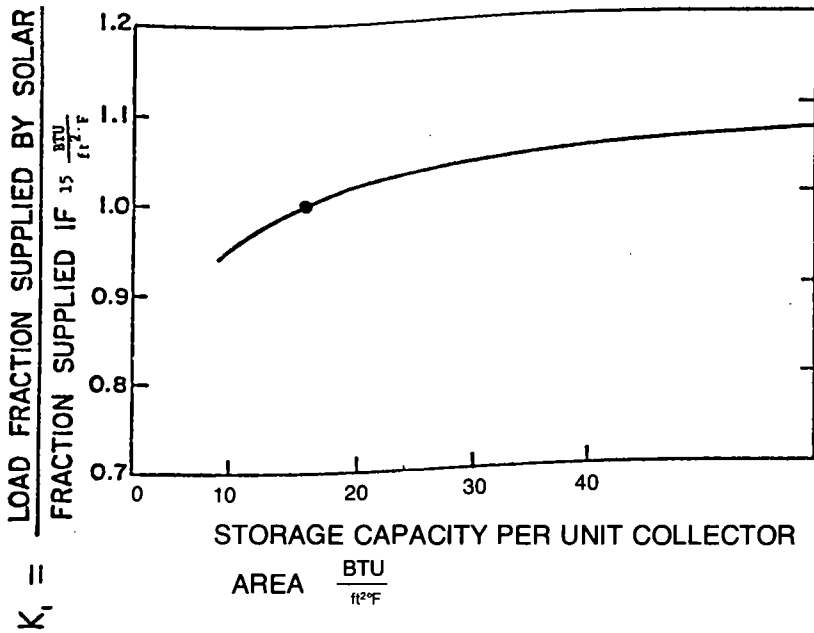

Correction factor (K_1) for storage capacities other than 15 BTU/ft²·F.

Subp. 7. Correction factor.

$$K_2 = \frac{\text{LOAD FRACTION SUPPLIED BY SOLAR}}{\text{FRACTION SUPPLIED IF } \frac{\epsilon_L (\dot{m}c_p)_{\min}}{UA} = 2}$$

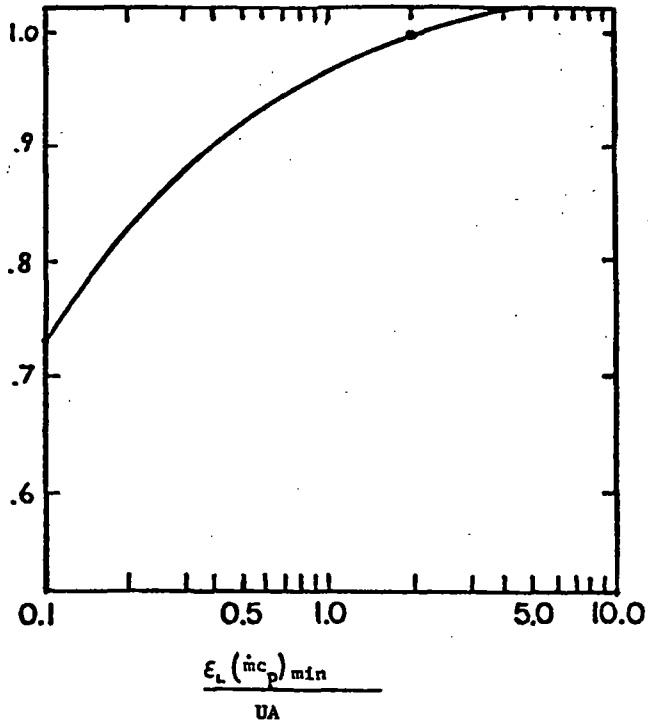

Correction factor (K_2) for various values of $L(\dot{m}c_p)_{\min}/UA$.

Statutory Authority: *MS s. 216C.25*

MINNESOTA RULES 1989

1325.9500 ENERGY

202

1325.9500 TABLE FOR CALCULATING FRACTION OF HEATING LOAD SUPPLIED BY SOLAR ENERGY.

DIMENSIONLESS PARAMETERS						FRACTION OF THE TOTAL HEATING LOAD SUPPLIED BY SOLAR ENERGY		
	BTU Month L	BTU Month ft ² S	HRS Month t	°F t _a	D ₁	D ₂	f	BTU Month E
Jan.			744					
Feb.			696					
Mar.			744					
April			720					
May			744					
June			720					
July			744					
Aug.			744					
Sept.			720					
Oct.			744					
Nov.			720					
Dec.			744					

E total =	_____	
L total =	_____	
F annual =	$\frac{E \text{ total}}{L \text{ annual}}$	
	=	_____
K ₁ =	_____	
K ₂ =	_____	
F' annual =	$(K_1) (K_2) F \text{ annual}$	
	=	_____

Statutory Authority: MS s 216C.25