

# MINNESOTA RULES 1985

141

NONMANDATORY BUILDING SECURITY RULES 1310.0300

## CHAPTER 1310 DEPARTMENT OF ADMINISTRATION STATE BUILDING CODE NONMANDATORY BUILDING SECURITY RULES

1310.0100	PURPOSE	1310.2800	REPORT
1310.0200	SCOPE.	1310.2900	TESTS FOR SECURITY OF WINDOW ASSEMBLIES; SCOPE.
1310.0300	LIMITATIONS.	1310.3000	DEFINITIONS.
1310.0400	DEFINITIONS.	1310.3100	TEST EQUIPMENT.
1310.0500	SWINGING DOORS.	1310.3200	DISASSEMBLY.
1310.0600	HORIZONTAL SLIDING DOORS.	1310.3300	SAMPLES FOR TESTING.
1310.0700	WINDOWS.	1310.3400	SAMPLE PREPARATION.
1310.0800	DISASSEMBLY.	1310.3500	TESTS FOR SLIDING WINDOWS.
1310.0900	ACCEPTANCE.	1310.3600	TESTS FOR HINGED WINDOW ASSEMBLIES.
1310.1000	ALTERNATE SECURITY PROVISIONS.	1310.3700	TESTS FOR PIVOTED WINDOW ASSEMBLIES.
1310.1100	TABLE OF TESTS FOR SWINGING DOOR ASSEMBLIES <sup>1</sup> .	1310.3800	MANIPULATION OF LOCKING DEVICE.
	<b>TEST STANDARDS</b>	1310.3900	PERFORMANCE REQUIREMENTS
1310.1200	TESTS FOR SWINGING DOORS.	1310.4000	REPORT.
1310.1300	DEFINITIONS.	1310.9000	DIRECTIONS AND POINTS OF LOAD APPLICATION FOR TESTING OF HORIZONTAL SLIDING DOORS.
1310.1400	SAMPLES FOR TESTING.	1310.9100	DIRECTIONS AND POINTS OF LOAD APPLICATION FOR TESTING OF TYPE A WINDOWS.
1310.1500	TEST EQUIPMENT PERFORMANCE.	1310.9200	DIRECTIONS AND POINTS OF LOAD APPLICATION FOR TESTING OF TYPES B AND C WINDOWS
1310.1600	CONSTRUCTION AND SIZE	1310.9300	DIRECTIONS AND POINTS OF LOAD APPLICATION FOR TESTING OF TYPE D WINDOWS
1310.1700	MOUNTING FOR TEST.		
1310.1800	CONDUCT OF TESTS.		
1310.1900	ACCEPTANCE CRITERIA.		
1310.2000	REPORT.		
1310.2100	TESTS FOR HORIZONTAL SLIDING DOORS; SCOPE.		
1310.2200	TEST EQUIPMENT.		
1310.2300	DISASSEMBLY.		
1310.2400	SAMPLES FOR TESTING.		
1310.2500	CONSTRUCTION AND SIZE		
1310.2600	TESTS		
1310.2700	PERFORMANCE REQUIREMENTS		

### 1310.0100 PURPOSE.

The purpose of this chapter is to provide minimum standards of design, construction, and quality of materials for all applicable buildings to safeguard life, property, and the public welfare from the perils of burglary and other unlawful trespasses.

**Statutory Authority:** *MS s 16B.59 to 16B.73*

### 1310.0200 SCOPE.

The provisions of this chapter shall apply to all accessible openings into dwelling units or guest rooms of Groups R-1, R-3, and R-4 occupancies.

**Statutory Authority:** *MS s 16B.59 to 16B.73*

### 1310.0300 LIMITATIONS.

Building security methods which will create a hazard to life by obstructing any means of egress or any opening which could be used as an emergency exiting facility shall be prohibited.

The provisions of this chapter shall not supersede the safety requirements relative to latching or locking devices on exit doors which would be contrary to the provisions of UBC chapter 33 nor shall the provisions of this chapter be construed to waive any other provisions of this code.

**Statutory Authority:** *MS s 16B.59 to 16B.73*

**1310.0400 DEFINITIONS.**

Subpart 1. **Scope.** For the purposes of this chapter, certain terms are defined as follows.

Subp. 2. **Accessible opening.** "Accessible opening" is any opening, or part thereof, in a wall defining the perimeter of a dwelling unit or guest room, which is located within 12 feet (3.63 m) vertically or six feet (1.83 m) horizontally of any surface or building appendage which would tend to supply access to said opening from either ground level or adjacent occupancies or structures. This definition also includes openings leading from breezeways, porches, or garage areas into dwelling units.

Subp. 3. **Horizontal sliding door assembly.** "Horizontal sliding door assembly" forms a closure for a passageway through a wall and consists of a frame, one or more operative panels that slide (roll) horizontally within the frame, and ancillary hardware such as rollers and locking devices. Such assemblies may also contain fixed panels which are fastened to the frame and/or to the wall in which the frame is installed.

Subp. 4. **Swinging door assembly.** "Swinging door assembly" is a unit composed of a group of parts or components that make up a closure for a passageway through a wall. For the purposes of this chapter, a door assembly consists of the following parts: door, hinges, locking device or devices, operation contacts (such as handles, knobs, push plates), miscellaneous hardware and closers, the frame, including the head and jambs, plus the anchorage devices to the surrounding wall.

Subp. 5. **Window assembly.** "Window assembly" is a unit composed of a group of parts or components that make up a closure for an opening in a wall to control light, air, and other elements, and which normally includes: glazed sash, hinges or pivots, sash lock, sash operator, window frame, miscellaneous hardware, and the anchorage between the window and the wall.

For additional definitions, see UBC Standards No. 41-1 and No. 41-2.

**Statutory Authority:** *MS s 16B.59 to 16B.73*

**1310.0500 SWINGING DOORS.**

Subpart 1. **General.** All accessible prime swinging door assemblies shall be designed, constructed, and installed so that, when in the locked position they shall not permit entry when subjected to the forces shown in parts 1310.9000 and tested in accordance with UBC Standard No. 41-1 Part A.

Subp. 2. **Entry vision.** All entry doors to dwelling units or guest rooms shall be arranged so that the occupant has a view of the area immediately outside the door without opening the door. Such view may be provided through approved view ports or glazed openings when provided in compliance with UBC Chapter 33, subpart 9 of this part, and part 1310.0700.

Subp. 3. **Frames; jambs.** Door jambs shall be installed with solid backing in such a manner that no voids exist between the strike jamb and the frame opening for a vertical distance of six inches (150 mm) each side of the strike.

Hollow metal frames shall be filled with concrete or similar noncrushable substance on the strike side of the frame.

In wood framing, horizontal blocking shall be placed between studs at door lock height for two stud spaces each side of the door opening. Trimmers shall be full length from the header to the floor with solid backing against sole plates.

Jambs for inswinging doors shall have the stop and jamb of one piece or equivalent construction.

Subp. 4. **Hinges.** Hinges for outswinging doors shall be equipped with nonremovable hinge pins or a mechanical interlock to preclude removal of the door from the exterior by removing the hinge pins. In wood framing, door frames shall be shimmed behind the hinges and such hinges shall be mounted

# MINNESOTA RULES 1985

143

## NONMANDATORY BUILDING SECURITY RULES 1310.0500

with a minimum of two No. 8 size screws, or equivalent, penetrating at least two inches (5 cm) into solid backing beyond the surface to which the hinge is attached.

Subp. 5. **Bolts and latches.** A minimum of one deadlocking bolt and one deadlocking latch, or equivalent, shall be provided for all accessible single swinging doors. Such bolts shall have minimum projections of one inch (25 mm) and such latches shall have minimum projections of one-half inch (12 mm).

Pairs of swinging doors shall have the inactive leaf secured by vertical throw bolts with a minimum projection of one-half inch (12 mm), or equivalent, and the active leaf shall be subject to the same provisions as for single swinging doors.

Exception: Doors connecting directly between dwelling units or guest rooms shall be equipped with a minimum of one deadlocking bolt which shall be key operated from both sides or equivalent.

Subp. 6. **Strikes.** Metal strikes shall be required for all locking devices and shall have a minimum thickness of .062 inches (1.5 mm). In wood framing, such strikes shall be mounted with a minimum of two No. 8 size screws, or equivalent, penetrating at least two inches (5 cm) into solid backing beyond the surface to which the strike is attached.

Strikes used for dead latches shall not allow the dead-latch plunger to enter the strike hole with the latch after installation.

Subp. 7. **Lock activating devices.** Lock cylinders shall be so designed or protected as to preclude disassembly from the exterior by twisting, prying, pulling, or other manipulation.

When key-in-knob locksets are constructed such that the deadbolt and dead latch are mechanically interconnected, such locksets shall be so designed or protected that the lock cannot be compromised by wrenching the knob from the exterior or knocking the knob off to gain access to the locking means and manipulating the bolt and latch by hand or with the aid of a screwdriver to gain access.

Subp. 8. **Keying requirements.** Keyed locks, other than master keyed locks, shall have a minimum of five tumblers or be of such design as to provide a minimum of 10,000 possible interchange-free combinations. Master-keyed locks shall provide a minimum of 1,000 interchange-free combinations.

A system of construction keying must be provided which will ensure that the use of construction keys will be precluded after occupancy by a new tenant or resident.

All dwelling units or guest rooms grouped within a building or complex shall have access locks keyed differently.

Subp. 9. **Door panels and glazing.** Door panels or glazing materials located within 36 inches (900 mm) of the inside lock activating device of an accessible swinging door assembly shall withstand the required impacts in accordance with the appropriate provisions of UBC Standard No. 41-1 Part A, Sec. 41.1007(h).

Exceptions: Openings in doors, when such openings do not exceed two inches (50 mm) in the smaller dimension.

When the glazing material is UL-listed burglary-resisting glazing material (UL Standard 972) installed in an approved manner according to manufacturer's specifications.

When the opening is protected by approved metal bars or grilles having a pattern such that the minimum dimension of any opening on the bars or grilles does not exceed two inches (50 mm).

**Statutory Authority:** *MS s 16B.59 to 16B.73*

# MINNESOTA RULES 1985

## 1310.0600 NONMANDATORY BUILDING SECURITY RULES

144

### 1310.0600 HORIZONTAL SLIDING DOORS.

All accessible prime horizontal sliding doors shall be designed, constructed, and installed so that, when in the locked position, they shall not permit entry when tested in accordance with UBC Standard No. 41-1 Part B.

**Statutory Authority:** *MS s 16B.59 to 16B.73*

### 1310.0700 WINDOWS.

All accessible prime windows assemblies shall be designed, constructed, and installed so that, when in the locked position, they shall not permit entry when tested in accordance with UBC Standard No. 41-2.

Exceptions: Fixed windows which are not designed to open; the glazing material of which may be installed in a sash, or may be installed directly into a window frame. Windows located more than 36 inches (900 mm) from the inside lock activating device of a swinging door assembly when such windows have a clear cross section of 96 inches<sup>2</sup> (600 cm<sup>2</sup>) or less and have as their smallest dimension a span of less than six inches (150 mm). Windows that are not emergency egress as regulated by UBC Sections 1304 and 1404, may be protected by approved metal bars or grilles having a pattern such that the minimum dimension of any opening in the bars or grilles shall not exceed two inches. The windows shall be equipped with a quick-acting release requiring no special knowledge or skill to operate.

**Statutory Authority:** *MS s 16B.59 to 16B.73*

### 1310.0800 DISASSEMBLY.

All accessible prime door and window assemblies and components shall incorporate no screws, bolts, nails, staples, or other mechanical fasteners which are accessible from the exterior and which could be removed by hand with the aid of a knife, screwdriver, or pliers within a period of five minutes, thus permitting entry by disassembly.

**Statutory Authority:** *MS s 16B.59 to 16B.73*

### 1310.0900 ACCEPTANCE.

The methods of installation and on-site assembly of swinging door units and other assemblies as described in this chapter shall be deemed to meet the standards of this chapter.

All assemblies and components which are otherwise subject to the standards of this chapter shall have a label or other identification indicating compliance with the applicable standards.

Exception: Such labeling requirements may be waived and the subject products deemed to qualify where proof of compliance satisfactory to the building official is submitted as per American National Standard Practice for Certification by Producer or Supplier, ANSI Z34.2-1969.

**Statutory Authority:** *MS s 16B.59 to 16B.73*

### 1310.1000 ALTERNATE SECURITY PROVISIONS.

The provisions of this chapter are not intended to prevent the use of any device or method of construction not specifically prescribed by this chapter when such alternate provides equivalent security and has been approved as provided by UBC 106 and UBC 107.

**Statutory Authority:** *MS s 16B.59 to 16B.73*

# MINNESOTA RULES 1985

145

## NONMANDATORY BUILDING SECURITY RULES 1310.1200

### 1310.1100 TABLE OF TESTS FOR SWINGING DOOR ASSEMBLIES<sup>1</sup>.

Test	Measure	Level
Static Bolt Lead <sup>2</sup>	Resistance	150 lbf (670 N)
Hinge Pin Tensile Lead <sup>3</sup>	Resistance	50 lbf (225 N)
Jamb/Wall Stiffness <sup>4</sup>	Force to Spread Increase in lock- front to strike space	1350 lbf (6000 N) 0.375 In.(9.5mm)
Knob Torque <sup>5</sup>	Resistance (25 N-m)	18.5 lbf-ft
Cylinder Core Lead	Resistance	290 lbf (1300 N)
Knob Impact <sup>5</sup>	Resistance	One blow of 74 ft- lbf(100 J)
Door Impact	Impact resistance at center and panel Impact resistance at glazing <sup>6</sup>	2 blows of 59 ft-lbf(80 J) One blow of 74 ft-lbf(100 J)
Hinge Impact	Impact resistance at hinge	2 blows of 59 ft-lbf(80 J)
Bolt impact	Impact resistance at bolt	2 blows of 59-lbf(80 J)

<sup>1</sup> For test methods see UBC Standard No. 41-1, part A.

<sup>2</sup> Minimum projection of 1 In. (25 mm) for bolts and 1/2 In. (12 mm) for latches.

<sup>3</sup> Applies to outswinging doors only.

<sup>4</sup> Bolt of latch must remain in strike.

<sup>5</sup> Applies to key-in-knob locksets where the bolt and the latch are mechanically interconnected such that a single action projects or retracts both.

<sup>6</sup> Does not apply when the glazing starts at a distance of 36 In. (900 mm) or more from the lock.

Note: lbf = pounds force.

**Statutory Authority:** *MS s 16B.59 to 16B.73*

### TEST STANDARDS

#### 1310.1200 TESTS FOR SWINGING DOORS.

See part 1310.0500.

Parts 1310.1200 to 1310.2000 cover test methods for swinging door assemblies that are required for building security by the State Building Code.

The wall assembly described in part 1310.1600 is considered suitable for the scope of these methods of test. Wall construction different in dynamic response from that described in part 1310.1600 may require testing according to part 1310.1800, subpart 4.

**Statutory Authority:** *MS s 16B.59 to 16B.73*

**1310.1300 DEFINITIONS.**

Subpart 1. **Bolt.** "Bolt" is a metal bar which, when actuated, is projected (or "thrown") either horizontally or vertically into a retaining member, such as a strike plate, to prevent a door from moving or opening.

Subp. 2. **Bolt projection.** "Bolt projection" (or "bolt throw") is the distance from the edge of the door, at the bolt center line, to the farthest point on the bolt in the projected position, when subjected to end pressure.

Subp. 3. **Component.** "Component," as distinguished from a part, is a subassembly which combines with other components to make up a total door assembly. The prime components of a door assembly include: door, lock, hinges, jamb/wall, jamb/strike, and wall.

Subp. 4. **Cylinder.** "Cylinder" is the cylindrical subassembly of a lock containing the cylinder core, tumbler mechanism, and the keyway. A double cylinder lock is one which has a key-actuated cylinder on both the exterior and interior of the door.

Subp. 5. **Cylinder core (or cylinder plug).** "Cylinder core" (or "cylinder plug") is the central part of a cylinder containing the keyway, which is rotated by the key to operate the lock mechanism.

Subp. 6. **Deadbolt.** "Deadbolt" is a lock bolt which does not have a spring action as opposed to a latch bolt, which does. The deadbolt must be actuated by a key and/or knob or thumb turn and when projected becomes locked against return by end pressure.

Subp. 7. **Dead latch (or deadlocking latch bolt).** "Dead latch" (or "deadlocking latch bolt") is a spring-actuated latch bolt having a beveled end and incorporating a plunger which, when depressed, automatically locks the projected latch bolt against return by end pressure.

Subp. 8. **Door assembly.** "Door assembly" is a unit composed of a group of parts or components which make up a closure for an opening to control passageway through a wall. For the purposes of this standard, a door assembly consists of the following parts: door; hinges; locking device or devices; operation contacts (such as handles, knobs, push plates); miscellaneous hardware and closers; the frame, including the head and jambs plus the anchorage devices to the surrounding wall, and a portion of the surrounding wall extending 36 inches (900 mm) from each side of the jambs and 16 inches (400 mm) above the head.

Subp. 9. **Jamb.** "Jamb" is a vertical member of a door frame to which the door is secured.

Subp. 10. **Jamb/strike.** "Jamb/strike" is that component of a door assembly which receives and holds secure the extended lock bolt; the strike and jamb used together are considered a unit.

Subp. 11. **Jamb/wall.** "Jamb/wall" is that component of a door assembly to which a door is attached and secured; the wall and jamb, used together, are considered a unit.

Subp. 12. **Key-in-knob.** "Key-in-knob" is a lockset having the key cylinder and other lock mechanisms such as a push or turn button contained in the knobs.

Subp. 13. **Latch (or latch bolt).** "Latch" (or "latch bolt") is a beveled, spring-actuated bolt, which may or may not have a deadlocking device.

Subp. 14. **Lock (or lockset).** "Lock" (or "lockset") is a keyed device (complete with cylinder, latch, or deadbolt mechanism, and trim such as knobs, levers, thumb turns, escutcheons, etc.) for securing a door in a closed position against forced entry. For the purposes of this standard, a lock does not include the strike plate.

# MINNESOTA RULES 1985

147

## NONMANDATORY BUILDING SECURITY RULES 1310.1500

Subp. 15. **Lock front.** "Lock front" is the outer plate through which the locking bolt projects and which is usually flush with the edge of the door.

Subp. 16. **Part.** "Part," as distinguished from component, is a unit (or subassembly) which combines with other units to make up a component.

Subp. 17. **Strike.** "Strike" is a metal plate attached to, or mortised into, a door or door jamb to receive and to hold a projected latch bolt and/or deadbolt in order to secure the door to the jamb.

Subp. 18. **Swinging door.** "Swinging door" is a stile- (side-) hinged door.

**Statutory Authority:** *MS s 16B.59 to 16B.73*

### 1310.1400 SAMPLES FOR TESTING.

Specimens shall be representative and the construction shall be verified by assembly drawings and bill of materials. Complete manufacturer or fabricator installation instructions and full-size or accurate scale templates for all items or hardware shall be included.

**Statutory Authority:** *MS s 16B.59 to 16B.73*

### 1310.1500 TEST EQUIPMENT PERFORMANCE.

Subpart 1. **Door ram.** The door ram shall be a pendulum system with a cylindrical weight capable of delivering horizontal impacts of 59 ft-lbf (80 J). The striking end of the weight shall be hemispherical and have a diameter of approximately six inches (150 mm). The impact nose may be made of any durable impact-resistant material such as epoxy polyamide resin.

Subp. 2. **Component ram.** The component ram shall be a pendulum system capable of delivering horizontal impacts of 74 ft-lbf (100 J). The pendulum weight shall be cylindrical with a maximum diameter of three inches (7.6 cm) and a striking end consisting of a one-fourth inch (six mm) carriage bolt, or equivalent.

Subp. 3. **Vertical impactor.** The vertical impactor shall be a rigid pendulum system consisting of a weight with a flat rectangular striking surface capable of delivering downward impacts of 74 ft-lbf (100 J).

Subp. 4. **Torque applicator.** The portable torque applicator shall be capable of delivering and measuring up to 18.5 lbf-ft (25 N-m) of torque to door knobs. The torque-loading adapter shall be designed to grip the knob.

Subp. 5. **Tension-loading device.** The tension-loading device shall be capable of delivering and measuring tensile forces of up to 290 lbf (1300 N).

Subp. 6. **Compression-loading device.** The compression-loading device shall be capable of delivering and measuring compressive forces of up to 150 lbf (670 N).

Subp. 7. **Jamb-spreading device.** The jamb-spreading device shall be capable of delivering to door jambs and measuring spreading forces of up to 1,350 lbf (6000 N) with a means of measuring up to one-half inch (12 mm) of spread in the door opening. The device shall have on each end either a loading-bearing plate or pressure foot which provides a minimum contact surface of 1-1/2 inches by five inches (38 mm by 125 mm).

Subp. 8. **Instrument accuracy.** All test monitoring equipment shall be calibrated to an accuracy of plus or minus five percent. The impact energy of each pendulum system shall be controlled to within plus or minus one percent.

Subp. 9. **Manipulation tools.** Tools used for manipulation tests of this standard shall consist of the following: a knife or spatula with a thin blade approximately 1/32 inch (0.8 mm) thick, not more than one inch (25 mm) wide and no longer than six inches (150 mm); slotted and Phillips type screwdrivers not exceeding ten inches (250 mm) in length; common hand and needle nose

# MINNESOTA RULES 1985

## 1310.1500 NONMANDATORY BUILDING SECURITY RULES

148

pliers not exceeding eight inches (200 mm) in length; and a piece of stiff steel wire with a diameter of approximately 1/16 inch (1.6 mm) and length of not in excess of three feet (900 mm).

**Statutory Authority:** *MS s 16B.59 to 16B.73*

### 1310.1600 CONSTRUCTION AND SIZE.

The construction and size of the test door assemblies, consisting of single doors, doors in pairs, special-purpose doors (such as Dutch doors), jambs and headers, and all hardware components shall be representative of that for which acceptance is desired.

The test fixture for door, door jamb, hinge, lock strike, and other components shall consist of a vertical wall section constructed from two by four wood studs, 16 inches (410 mm) on center with double studding around the rough openings and outer edges of the fixture. The test fixture shall be covered with one-half inch (12 mm) exterior grade plywood sheathing on the exterior and one-half inch (12 mm) gypsum board on the interior and shall be secured to a supporting fixture and to the laboratory floor such as to simulate the rigidity normally provided to a door assembly in a building by the ceiling, floor, and walls.

An alternate test fixture for lockset components consisting of a small door assembly may be used. The frame shall be fabricated from steel angle and plate at least 3/16 inch (5 mm) thick. The test panel shall be 24 inches (600 mm) square and 1-3/4 inches (45 mm) thick, made by bonding three pieces of plywood together or by cutting a section from 1-3/4 inch (45 mm) solid wood core door. A two by two by one-eighth inch (50 by 50 by 3 mm) steel angle shall be bolted to the hinge edge of the door panel, and a removable steel strike plate shall be bolted to the frame at the lock position of the door panel.

The test fixture for static bolt load tests shall consist of a vertical panel fabricated from wood attached to a stable horizontal base. The top edge shall be about 1-3/4 inches (45 mm) thick and the top edge shall be prepared to permit the lockset which is being tested to be mounted in the panel in accordance with the manufacturer's instructions.

**Statutory Authority:** *MS s 16B.59 to 16B.73*

### 1310.1700 MOUNTING FOR TEST.

Prepare doors and door jambs for the installation of locksets and hinges in conformance with the manufacturer's instructions. Follow the manufacturer's instructions for fastening the jamb to the test fixture described in part 1310.1600.

To test doors, door jambs, hinges, and jamb/strikes as components, install them in the component test fixture described in part 1310.1600. Except when testing hinges, hinge the door with 1-1/2 pair of 4-1/2 inch (115 mm) steel butt hinges, and fix it in the closed-locked position (at the normal lock point) with a real or simulated latch bolt having sufficient strength and stiffness to prevent it from failing during test. In the absence of other construction specifications, make the clearances on the lock side, hinge side, and top of the door 1/8 plus or minus 1/64 inch (3.2 plus or minus .04 mm). Clearance at the threshold is not considered critical in these tests.

To test locksets as components, install them in the alternate component test fixture described in part 1310.1600. Fix the test panel in the closed-locked position at the normal locking point. Hinge the test panel with two 4-1/2 inch (115 mm) steel butt hinges.

To test locksets for static bolt load, install them in the test fixture described in part 1310.1600.

**Statutory Authority:** *MS s 16B.59 to 16B.73*



# MINNESOTA RULES 1985

149

## NONMANDATORY BUILDING SECURITY RULES 1310.1800

### 1310.1800 CONDUCT OF TESTS.

Subpart 1. **Test sequence.** Perform tests in the same sequence as presented below, as appropriate for the item under test, using new components for each destructive test.

Subp. 2. **Static bolt load test.** To test locks as components, mount the lock in the test fixture described in part 1310.1700. Lock the door lock with the deadbolt and dead latch in the fully projected position. If the lock incorporates a dead latch plunger, attach a one-fourth inch (6.5 mm) spacer to the lock front. Allow the dead latch plunger to project flush with the top of the spacer, and hold it in that position with a piece of tape or by other suitable means.

Place the test fixture and lock in a compression-testing machine, or mount it on a firm, level surface with the compression-loading device directly above it, the loading face parallel to the lock front, and the axis of the hydraulic ram perpendicular to the lock front. Apply an increasing compressive load to the end of the latch bolt or the deadbolt to the required resistance load and note the bolt or latch projection (the distance between the lock front surface to the farthest point on the bolt or latch at the center line). Such projection shall not be less than one-fourth inch (6.5 mm) while under load.

To test for bolt projection, apply end pressure to the projected deadbolt or latch and measure the distance from the lock front surface to the farthest point on the bolt or latch at the center line.

Following the test of a lock incorporating a dead latch, place the strike plate over the latch of a dead latch to determine whether it is possible for both the dead latch and the dead latch plunger to enter the hole in the strike simultaneously.

Subp. 3. **Hinge pin tensile load.** Drill a hole into the end of the exposed hinge pin with a No. 21 drill, centered on and aligned with the axis of the pin to a depth of 0.5 inch (12 mm). Tap the hole with a 10-32 tap and attach the tensile-loading adapter to it with a hardened cap screw. Clamp one leaf of the hinge in a vise so that the hinge pin is in the horizontal plane. Attach the tensile-loading device to a rigid load-bearing support in front of the hinge and align the pulling axis with the axis of the hinge pin. Attach the tensile-loading adapter to the tensile device and apply the required load.

Subp. 4. **Jamb; wall stiffness test.** Prepare the test specimen in accordance with part 1310.1700 using the full-size test fixture. Position the jamb-spreading device between the door jambs at lock height. Apply increasing force as required and measure the space between the lock front and strike.

While the required load is being applied, or the lock front-to-strike distance increased, push or pull on the door to determine whether the deadbolt or dead latch is engaged with the strike.

Subp. 5. **Knob torque test.** Prepare the test specimen in accordance with part 1310.1700 and lock the door or test panel in the closed position. Attach the torque-loading adaptor to the knob and connect the torque applicator to it. Alternately subject the knob to a torque of up to the required torque once in both the clockwise and counter-clockwise directions, applying the torque as rapidly as possible. Inspect the lock to determine whether the bolt is retracted from the strike when the torque is applied. If the knob is broken off, attempt to open the door or test panel by manipulating the lock mechanism by hand or with the aid of manipulation tools as described in part 1310.1500, subpart 9 (such lock mechanism shall resist manipulation for a period of not less than five minutes).

With the door or test panel open, and the deadbolt or dead latch in the projected, locked position, attempt to:

- A. depress the deadbolt by applying hand pressure to its end; or
- B. depress latch and dead latch plunger fully, allow the latch to extend, then slowly allow the plunger to project until the last point of dead locking is reached.

# MINNESOTA RULES 1985

## 1310.1800 NONMANDATORY BUILDING SECURITY RULES

150

Subp. 6. **Cylinder core tension test.** Prepare the test specimen in accordance with part 1310.1700 and lock the door or test panel in the closed position. Using a No. 21 drill, drill a hole in the cylinder core adjacent to the keyway to a minimum depth of one-half inch (12 mm). Tap this hole with a 10-32 thread. Attach the tensile-loading device to a rigid load-bearing support in front of the cylinder and align the pulling axis with a 10-32 hardened cap screw fully threaded into the tapped hole. Connect the cylinder tensile-loading device to the adaptor and apply the required tensile force to the cylinder. Following this test, release the load and attempt to open the door or test panel by manipulating an exposed lock mechanism for a period of five minutes by hand or with the aid of manipulation tools as described in part 1310.1500, subpart 9. If the core or cylinder is not damaged, open the door and test the dead latch and deadbolt for end pressure resistance as in subpart 5.

Subp. 7. **Knob impact test.** Prepare the test specimen in accordance with part 1310.1700 and lock door or test panel in the closed position. Position the vertical impactor so that the pendulum arm is horizontal when the striking weight contacts the top of the door knob, and its center of gravity is in the vertical center line through the knob. Raise the weight to the height necessary to deliver the required impact and release it. Deliver the required number of impacts to the knob. After each impact, attempt to open the door or test panel by turning the knob, and if the knob is broken off, by manipulating the exposed lock mechanism by hand or with the aid of manipulation tools as described in part 1310.1500, subpart 9. Such lock mechanism shall resist manipulation for a period of not less than five minutes. Open the door and test the dead latch and deadbolt for end pressure resistance as in subpart 5.

Subp. 8. **Door impact test.** Prepare the test specimen in accordance with part 1310.1700, using the full-size test fixture, and lock the door in the closed position. Set up the door ram pendulum weight so that its axis is horizontal, and perpendicular to the face of the door at a point defined by the intersection of the vertical center line of the door and a line of the door and a line from the center of the bolt to the center of the mid-height hinge (or the midpoint between hinges, when the door is hung with two hinges).

Attach to the door, centered on the impact point, a rigid foamed polystyrene impact buffer which has a diameter of six inches (150 mm), a thickness of two inches (50 mm) and a density of two pounds per cubic foot (32 kilograms per cubic meter). Position the door ram such that its striking nose just touches the surface of the buffer when at rest. Pull back the pendulum weight to the height necessary to produce the required impact, and release it. Subject the door to two impacts at each required impact level, attaching a new buffer for each impact. If the door is forced open by the test, without damaging the jamb/strike or lock component, the door specimen fails the test. If the door surface is broken, attempt to reach inside the door and unlock it from the inside.

If the door has one or more recessed panels, subject the one closest to the lock to two impacts at each required impact level. Locate the impact point on the corner of the panel closest to the lock, three inches (75 mm) in from the vertical and horizontal edges of the panel. Perform the test as described above, attaching a new impact buffer for each impact. If the panel is broken, attempt to open the door by reaching through the opening and unlocking the door from the inside.

To test glazing panels, set up the component ram pendulum weight so that, at rest, its striking nose just touches the front surface at a point located along a line from the center of the inside lock activating device through the closest point on the perimeter of the glazing panel, which is within 36 inches (900 mm), and just far enough onto the panel to ensure that the impactor clears the edge of the door and the panel. Pull back the pendulum weight to the height necessary to produce the required impact and release it. If the panel is broken, reach

# MINNESOTA RULES 1985

151

## NONMANDATORY BUILDING SECURITY RULES 1310.1900

through the opening and attempt to open the door by unlocking it from the inside.

Following the door impact test, inspect the door to determine whether there is enough damage to invalidate the subsequent tests; if there is, replace it.

Subp. 9. **Hinge impact test.** Prepare the test specimen in accordance with part 1310.1700 using the full-size test fixture and lock the door in a closed position. When testing hinges incorporating a mechanical interlock between the leaves in the closed position and door assemblies using such hinges, remove the hinge pin during this test. Set up the door ram pendulum weight so that its axis is horizontal, and perpendicular to the exterior face of the door at a point eight inches (200 mm) from the bottom hinge on a horizontal line through the midpoint of the hinge.

Attach an impact buffer as described in subpart 8 to the face of the door, centered on the impact point, and position the pendulum so that its striking nose just touches the surface of the buffer when at rest. Pull back the pendulum weight to the height necessary to produce the required impact and release it. Subject the door to two impacts at each required impact level, attaching a new buffer for each impact. After each impact, try to open the door.

A door component failure consists of any splitting or fracture of the door which allows it to be opened; a jamb component failure consists of any splitting, fracture, or pullout of the attachment screws which allows the door to be opened; a hinge component failure consists of any damage to the leaves or pin of the hinge which allows the door to be opened.

Following the hinge impact test, inspect the components to determine whether there is sufficient damage to invalidate the subsequent test; if there is, replace those damaged.

Subp. 10. **Bolt impact test.** Prepare the test specimen in accordance with part 1310.1700 and lock the door in the closed position. Set up the door ram pendulum weight so that its axis is horizontal, and perpendicular to the face of the door at a point defined by the intersection of a vertical line eight inches (200 mm) from the lock edge, and a line from the center of the bolt to the center of the mid-height hinge (or the midpoint between hinges when the door is hung with two hinges).

Attach an impact buffer as described in subpart 8 to the face of the door, centered on the impact point, and position the pendulum so that it just touches the surface of the buffer when at rest. Pull back the pendulum weight to the height necessary to produce the required impact and release it. Subject the door to two impacts at each required impact level, attaching a new buffer for each impact. After each impact, try to open the door or test panel by turning the knob, and test the deadbolt and dead latch for end pressure resistance as in subpart 5.

**Statutory Authority:** *MS s 16B.59 to 16B.73*

### 1310.1900 ACCEPTANCE CRITERIA.

Subpart 1. **General.** An item shall fail a test if an individual can open the door from the outside by pushing or pulling on it, by turning the knob, by manipulating an exposed lock mechanism, by reaching through damaged portions of the door and unlocking it from the inside; or can enter through damaged portions of the door even though it might not be possible to open the door; or if the dead latch or deadbolt can be depressed by a static load applied by hand after being subjected to the levels of energy set forth in the Uniform Building Code.

A jamb/strike component failure consists of a pullout or fracture of the strike attachment screws or any splitting, bending, or fracture of the door jamb at the strike which permits the door to be opened; a door component failure consists of any splitting or fracture of the door which allows it to be opened; a

# MINNESOTA RULES 1985

## 1310.1900 NONMANDATORY BUILDING SECURITY RULES

152

lock component failure consists of any damage to the lock mechanism or bolt which allows the door to be opened after being subjected to the levels of energy set forth in the Uniform Building Code.

Subp. 2. **Disassembly.** Door assemblies and components shall incorporate no screw, bolt, nail, staple, or other mechanical fastener which is accessible from the outside and which could be removed by hand or with the aid of manipulation tools as described in part 1310.1500, subpart 9 within a period of five minutes thus permitting entry by disassembly.

Subp. 3. **Strike hole size.** For locks incorporating dead latches, the size of the latch retaining hole in the strike shall be such that it shall not be possible for both the dead latch and dead latch plunger to enter the hole together when the latch is fully extended.

Subp. 4. **Bolt pressure resistance.** When locks are tested, the force required to depress the latch or deadbolt from the locked and projected position shall not be less than specified in the Uniform Building Code.

**Statutory Authority:** *MS s 16B.59 to 16B.73*

### 1310.2000 REPORT.

The test report shall include:

A. name and address of the facility or laboratory performing these tests and issuing the report as well as the dates of testing and issuance of the report;

B. identification of the sample tests (e.g., name of manufacturer, model, and/or series number of product, and other information as may be pertinent);

C. final assembly drawing(s) and components list relative to type, size, location, and number of anchors, locking devices, and mounting screws used;

D. statement indicating that specimen either passed or failed these tests; and

E. statement that all tests were conducted in accordance with these procedures.

**Statutory Authority:** *MS s 16B.59 to 16B.73*

### 1310.2100 TESTS FOR HORIZONTAL SLIDING DOORS; SCOPE.

See part 1310.0600.

Parts 1310.2100 to 1310.2800 cover test methods for sliding door assemblies that are required for building security by the Uniform Building Code.

**Statutory Authority:** *MS s 16B.59 to 16B.73*

### 1310.2200 TEST EQUIPMENT.

Four tension-loading devices capable of delivering and measuring tensile forces of up to 300 lbf (1340 N) with an accuracy of plus five percent for each applied load level are required for these tests.

Manipulation tools shall consist of: a knife or spatula with a thin blade approximately 1/32 inch (0.8 mm) thick, not more than one inch (25 mm) wide and no longer than six inches (150 mm); slotted and Phillips type screwdrivers not exceeding ten inches (250 mm) in length; common hand and needle nose pliers not exceeding eight inches (200 mm) in length; and a piece of stiff steel wire with a diameter of approximately 1/16 inch (1.6 mm) and a length of not in excess of three feet (900 mm).

**Statutory Authority:** *MS s 16B.59 to 16B.73*

# MINNESOTA RULES 1985

153

NONMANDATORY BUILDING SECURITY RULES 1310.2600

## 1310.2300 DISASSEMBLY.

Door assemblies and components shall incorporate screw, bolt, nail, staple, or other mechanical fastener which is accessible from the outside and which could be removed by hand or with the aid of manipulation tools as described in part 1310.2200 within a period of five minutes thus permitting entry by disassembly.

**Statutory Authority:** *MS s 16B.59 to 16B.73*

## 1310.2400 SAMPLES FOR TESTING.

Specimens shall be representative, and the construction shall be verified by assembly drawings and bill of materials. Complete manufacturer or fabricator installation instructions and full-size or accurate scale templates for all items and hardware shall be included.

**Statutory Authority:** *MS s 16B.59 to 16B.73*

## 1310.2500 CONSTRUCTION AND SIZE.

The construction and size of the test door assemblies, jambs and headers, and all hardware components shall be representative of that for which acceptance is desired.

The door assembly and mounting in the support fixture shall simulate the rigidity normally provided to a door assembly in a building by the ceiling, floor, and walls.

**Statutory Authority:** *MS s 16B.59 to 16B.73*

## 1310.2600 TESTS.

Subpart 1. **Preparation.** Sample doors submitted for testing shall be glazed. Panels shall be closed and locked. Holes may be drilled at convenient locations on the assembly to attach load adapter brackets and the glazing may be taped to prevent possible injury from shattering under load. Loads may be applied from either the interior or exterior side of the door.

Prior to testing, remove from the sliding door assembly all mechanical fasteners which can be removed from the exterior by hand or with the aid of manipulation tools, as described in part 1310.2200, within a period of five minutes.

Tests shall be performed in the following order.

Subp. 2. **Test I.** With the panels in the normal position, a concentrated load of 300 pounds (1340 N) shall be applied separately to each vertical stile incorporating a locking device, at a point on the stile within six inches (150 mm) of the locking device, in the direction parallel to the plane of the glass that would tend to open the door. Remove the load and determine if the locking device can be unlocked by manipulation as described in Test VIII.

Subp. 3. **Test II.** With panels in the normal position, a concentrated load of 300 pounds (1340 N) shall be applied separately to each vertical pull stile incorporating a locking device, at a point on the stile within six inches (150 mm) of the locking device, in the direction parallel to the plane of the glass that would tend to open the door while, simultaneously, an additional concentrated load of 150 pounds (670 N) is applied to the same area of the same stile in a direction perpendicular to the plane of glass toward the interior side of the building. Remove the load and determine if the locking device can be unlocked by manipulation as described in Test VIII.

Subp. 4. **Test III.** With the panels in the normal position, a concentrated load of 300 pounds (1340 N) shall be applied separately to each vertical pull stile incorporating a locking device, at a point on the stile within six inches (150 mm) of the locking device, in the direction parallel to the plane of the glass that would tend to open the door while, simultaneously, an additional concentrated load of 150 pounds (670 N) is applied to the same area of the same stile in the

direction perpendicular to the plane of the glass toward the exterior side of the door. Remove the load and determine if the locking device can be unlocked by manipulation as described in Test VIII.

Subp. 5. **Test IV.** With the movable panel lifted upward to its full limit within the confines of the door frame (a force of 150 pounds or 670 N, plus the weight of the panel, shall be divided equally and applied to the bottom rail within six inches (150 mm) of the corners to move panels upward), a concentrated load of 300 pounds (1340 N) shall be applied separately to each vertical pull stile incorporating a locking device, at a point on the stile within six inches (150 mm) of the locking device, in the direction parallel to the plane of the glass that would tend to open the door. With the loads applied, determine if the locking device can be unlocked by manipulation as described in Test VIII.

Subp. 6. **Test V.** With the movable panel lifted upward to its full limit within the confines of the door frame as described in Test IV, a concentrated load of 300 pounds (1340 N) shall be applied separately to each vertical pull stile incorporating a locking device, at a point on the stile within six inches (150 mm) of the locking device, in the direction parallel to the plane of the glass that would tend to open the door while, simultaneously, an additional concentrated load of 150 pounds (670 N) is applied to the same area of the same stile in the direction perpendicular to the plane of the glass toward the interior side of the door. With the loads applied, determine if the locking device can be unlocked by manipulation as described in Test VIII.

Subp. 7. **Test VI.** With the movable panel lifted upward to its full limit within the confines of the door panel as described in Test IV, a concentrated load of 300 pounds (1340 N) shall be applied separately to each vertical stile incorporating a locking device, at a point on the stile within six inches (150 mm) of the locking device, in the direction parallel to the plane of the glass that would tend to open the door while, simultaneously, an additional concentrated load of 150 pounds (670 N) is applied to the same area of the same stile in the direction perpendicular to the plane of the glass toward the exterior side of the door. With the loads applied, determine if the locking device can be unlocked by manipulation as described in Test VIII.

Subp. 8. **Test VII.** For inside sliding doors, repeat Test V while simultaneously applying a concentrated load of 50 pounds (220 N) at the end of the movable bottom rail near the interlock stiles and inward. For outside sliding doors, repeat Test VI while simultaneously applying a concentrated load of 50 pounds (220 N) at the end of the movable bottom rail near the interlock stiles and outward.

Subp. 9. **Test VIII.** Examine the assembly and determine a method and position for inserting a tool through the door assembly from the outside so as to contact the locking device or the latch. Determine whether it is possible to insert or manipulate with any of the manipulation tools described in part 1310.2200 so as to unlock the door. Such assemblies shall resist manipulation for a period of not less than five minutes.

Subp. 10. **Test IX.** Repeat Tests I, II, and III for fixed panels locating the load point at the midpoint of the stile opposite the meeting stile of the panel under test.

**Statutory Authority:** *MS s 16B.59 to 16B.73*

### 1310.2700 PERFORMANCE REQUIREMENTS.

A sliding door assembly shall fail these tests if at any time during or after the test the sliding door assembly does not remain engaged, intact, and in the closed and locked position; or if one can enter by manipulating an exposed component or through displaced or damaged portions.

**Statutory Authority:** *MS s 16B.59 to 16B.73*

# MINNESOTA RULES 1985

155

## NONMANDATORY BUILDING SECURITY RULES 1310.3000

### 1310.2800 REPORT.

See part 1310.2000.

**Statutory Authority:** *MS s 16B.59 to 16B.73*

### 1310.2900 TESTS FOR SECURITY OF WINDOW ASSEMBLIES; SCOPE.

Parts 1310.2900 to 1310.4000 cover test methods for window assemblies that are required for building security by the Uniform Building Code. For the purpose of parts 1310.2900 to 1310.4000 windows are classified as follows.

Type A window assemblies incorporate one or more sashes that open by sliding in the plane of the wall in which the window is installed.

Type B window assemblies incorporate one or more framed sashes which are hinged at or near two corners of the individual sash and open toward the exterior of the wall.

Type C are window assemblies which incorporate one or more sashes which open toward the interior and are hinged at or near two corners of the sash.

Type D are window assemblies which incorporate one or more sashes which are hinged or pivot near the center so that part of the sash opens into the interior wall and part opens toward the exterior.

**Statutory Authority:** *MS s 16B.59 to 16B.73*

### 1310.3000 DEFINITIONS.

Subpart 1. **Jamb.** See "window frame."

Subp. 2. **Locking device.** "Locking device" is a part of a window assembly which is intended to prevent movement of the movable sash, which may be the sash lock or sash operator.

Subp. 3. **Mullion.** "Mullion" is a window frame member which meets with and provides structural support to a pair of adjacent sashes at their meeting edges.

Subp. 4. **Muntin.** "Muntin" is a structural member of a sash which extends either horizontally between the stiles or vertically between the rails to support individual panes of glazing material when the sash incorporates two or more panes.

Subp. 5. **Rail.** "Rail" is a horizontal member of a sash frame. A meeting rail is one which mates with a rail of another sash or a framing member of the window frame when the sash is in the closed position.

Subp. 6. **Sash.** "Sash" is an assembly of stiles, rails, and sometimes muntins assembled into a single frame which supports the glazing material. A fixed sash is one which is not intended to be opened. A movable sash is intended to be opened.

Subp. 7. **Sill.** "Sill" is the lowest horizontal member of a window frame.

Subp. 8. **Stile.** "Stile" is a vertical framing member of a sash. A meeting stile is one which mates with a stile of another sash, or a vertical framing member of the window frame when the sash is in the closed position.

Subp. 9. **Window assembly.** "Window assembly" is a unit which includes a window and the anchorage between the window and the wall.

Subp. 10. **Window frame.** "Window frame" is that part of a window which surrounds and supports the sashes and is attached to the surrounding wall. The members include side jambs (vertical), head jamb (upper, horizontal), sill, and mullions.

**Statutory Authority:** *MS s 16B.59 to 16B.73*

**1310.3100 TEST EQUIPMENT.**

Four tension-loading devices capable of delivering and measuring tensile forces of up to 150 lbf (670 N) with an accuracy of plus or minus five percent for each applied load level are required for these tests.

Manipulation tools shall consist of: a knife or spatula with a thin blade approximately 1/32 inch (0.8 mm) thick, not more than one inch (25 mm) wide and no longer than six inches (150 mm); slotted and Phillips type screwdrivers not exceeding ten inches (250 mm) in length; common hand and needle nose pliers not exceeding eight inches (200 mm) in length; and a piece of stiff steel wire with a diameter of approximately 1/16 inch (1.6 mm) and length of not in excess of three feet (900 mm).

**Statutory Authority:** *MS s 16B.59 to 16B.73*

**1310.3200 DISASSEMBLY.**

Window assemblies and components shall not include screws, bolts, nails, staples, or other mechanical fasteners which are accessible from the exterior and which could be removed by hand or with the aid of manipulation tools as described in part 1310.3100 within a period of five minutes thus permitting entry by disassembly.

**Statutory Authority:** *MS s 16B.59 to 16B.73*

**1310.3300 SAMPLES FOR TESTING.**

Specimens shall be representative, and the construction shall be verified by assembly drawings and bill of materials. Complete manufacturer or fabricator installation instructions and full-size or accurate scale templates for all items and hardware shall be included.

**Statutory Authority:** *MS s 16B.59 to 16B.73*

**1310.3400 SAMPLE PREPARATION.**

Following the manufacturer's installation instructions, install the window assembly in a rigid test fixture which simulates the rigidity normally provided to a window assembly in a building. The unit shall be fully glazed. Holes may be drilled in the sash at convenient locations to attach load adapter brackets and the glazing may be taped to prevent possible injury from shattering under load. Loads may be applied from either the interior or exterior side of the window.

Before performing any test, remove from the window assembly all screws, bolts, hinge pins, rigid snap glazing beads, or other mechanical fasteners which can be removed from the exterior by hand or with the aid of manipulation tools as described in part 1310.3100. Sashes shall be closed and locked.

**Statutory Authority:** *MS s 16B.59 to 16B.73*

**1310.3500 TESTS FOR SLIDING WINDOWS.**

Subpart 1. **General.** Tests for Type A window assemblies shall be performed in the following order.

Subp. 2. **Test I.** With each sliding sash in the normal position, a concentrated load of 150 pounds (670 N) shall be applied separately to each sash member incorporating a locking device, at a point on a sash member within six inches (150 mm) of the locking device, in a direction parallel to the plane of the glass that would tend to open the window. Remove the load and apply the manipulation test described in part 1310.3800.

Subp. 3. **Test II.** With each sliding sash in the normal position, a concentrated load of 150 pounds (670 N) shall be applied separately to each sash member incorporating a locking device, at a point on a sash member within six inches (160 mm) of the locking device, in the direction parallel to the plane of the glass that would tend to open the window while, simultaneously, an additional concentrated load of 75 pounds (340 N) is applied in the same area of



# MINNESOTA RULES 1985

157

## NONMANDATORY BUILDING SECURITY RULES 1310.3500

the same sash member in the direction perpendicular to the plane of the glass toward the interior side of the window. Remove the load and apply the manipulation test described in part 1310.3800.

Subp. 4. **Test III.** With each sliding sash in the normal position, a concentrated load of 150 pounds (670 N) shall be applied separately to each sash member incorporating a locking device, at a point on the sash member within six inches (150 mm) of the locking device, in a direction parallel to the plane of the glass that would tend to open the window while, simultaneously, an additional concentrated load of 75 pounds (340 N) is applied to the same sash member in a direction perpendicular to the plane of the glass toward the exterior side of the window. Remove the load and apply the manipulation test described in part 1310.3800.

Subp. 5. **Test IV.** For horizontal sliding windows, move the sliding sash upward by applying a force of 75 pounds, plus the weight of the sash, divided equally between the lower corners of the sash. For vertical sliding or hung type windows, move the sash toward the side offering the least resistance by applying a force of 75 pounds (340 N) to the side corners opposite the frame member towards which the window is being moved. Simultaneously, apply a concentrated load of 150 pounds (670 N) to each sash member incorporating a locking device, at a point on the sash within six inches (150 mm) of the locking device, in the direction parallel to the plane of the glass that would tend to open the window. With the assembly under load, apply the manipulation test described in part 1310.3800.

Subp. 6. **Test V.** With the sliding sash moved upward (for horizontal sliding windows) or to the side (for vertical or hung-type windows) within the confines of the window frame as described in Test IV, a concentrated load of 150 pounds (670 N) shall be applied separately to each sash member incorporating a locking device, at a point on the sash within six inches (150 mm) of the locking device, in a direction parallel to the plane of the glass that would tend to open the window while, simultaneously, an additional concentrated load of 75 pounds (340 N) is applied to the same area of the same sash in the direction perpendicular to the plane of the glass toward the interior side of the window. With the assembly under load, apply the manipulation test described in part 1310.3800.

Subp. 7. **Test VI.** With the sliding sash moved upward (for horizontal sliding windows) or to the side (for vertical sliding or hung-type windows) within the confines of the window frame as described in Test IV, a concentrated load of 150 pounds (670 N) shall be applied separately to each sash member incorporating a locking device, at a point on the sash member within six inches (150 mm) of the locking device, in the direction parallel to the plane of the glass that would tend to open the window while, simultaneously, an additional concentrated load of 75 pounds (340 N) is applied to the same sash member in the direction perpendicular to the plane of the glass toward the exterior side of the window. With the assembly under load, apply the manipulation test described in part 1310.3800.

Subp. 8. **Test VII.** For inside sliding windows, repeat Test V while simultaneously applying a concentrated load of 25 pounds (110 N) at the end of the movable sash member located opposite the frame member toward which the sash is either moved or lifted and near the corner which is furthest from the locking device; such load shall be applied perpendicular to the sash and toward the interior. For outside sliding windows, repeat Test VI while simultaneously applying a concentrated load of 25 pounds (110 N) located in the same manner as for inside sliding windows, but applied in the opposite direction or toward the exterior.

Subp. 9. **Test VIII.** Repeat Tests I, II, and III for fixed sashes, which are part of a Type A window assembly, locating the load point at the midpoint of the stile or rail opposite the meeting stile or rail of the sash under test.

**Statutory Authority:** *MS s 16B.59 to 16B.73*

### 1310.3600 TESTS FOR HINGED WINDOW ASSEMBLIES.

Subpart 1. **General.** Tests for Types B and C window assemblies shall be performed in the following order. The manipulation test described in part 1310.3800 shall be applied after Tests I and II while the sash is under load and after Test IV with the loads removed.

Subp. 2. **Test I.** With the swinging sash in the normal position, simultaneously apply a concentrated load of 75 pounds (340 N) within three inches (75 mm) of each end of the rail or stile which is opposite the hinged side, in the direction perpendicular to the plane of the glass that would tend to open the window.

Subp. 3. **Test II.** Repeat Test I and simultaneously apply a load of 75 pounds (340 N) on the outside within one inch (25 mm) of each end of the stile or rail which is opposite the hinge side, in a direction parallel to the plane of the glazing which would tend to disengage the lock. Remove the loads.

Subp. 4. **Test III.** With the swinging sash in the normal position, apply a concentrated load of 150 pounds (670 N) on the rail or stile containing the locking device within six inches (150 mm) of the lock in a direction perpendicular to the plane of the glass that would tend to open the window.

Subp. 5. **Test IV.** Repeat Test III and simultaneously apply a load of 75 pounds (340 N) on the outside within one inch (25 mm) of each end of the stile or rail which is opposite the hinge side, in a direction parallel to the plane of the glazing which would tend to disengage the lock.

**Statutory Authority:** *MS s 16B.59 to 16B.73*

### 1310.3700 TESTS FOR PIVOTED WINDOW ASSEMBLIES.

Subpart 1. **General.** Tests for Type D window assemblies shall be performed in the following order. The manipulation test described in part 1310.3800 shall be applied after Tests I and II while the sash is under load and after Test IV with the loads removed.

Subp. 2. **Test I.** With the sash in the normal position, simultaneously apply a concentrated load of 37.5 pounds (170 N) within three inches (75 mm) of both ends of each rail or stile which is perpendicular to the pivot sides in the direction that would tend to open the sash. Remove the loads.

Subp. 3. **Test II.** With the sash in the normal position, apply a concentrated load of 75 pounds (340 N) on a rail or stile containing a pivot within one inch (25 mm) of the pivot in a direction parallel to the pivots tending to disengage the pivot under test.

Subp. 4. **Test III.** Repeat Test II, applying the load to the opposite rail or stile. Remove the load.

Subp. 5. **Test IV.** With the sash in the normal position, apply a concentrated load of 150 pounds (670 N) on the rail or stile containing the locking device within six inches (75 mm) of the lock in a direction perpendicular to the sash and tending to open the window.

Subp. 6. **Test V.** Repeat Test IV while simultaneously applying the load specified in Test II. Repeat Test IV while simultaneously applying the load specified in Test III.

**Statutory Authority:** *MS s 16B.59 to 16B.73*

# MINNESOTA RULES 1985

159

## NONMANDATORY BUILDING SECURITY RULES 1310.4000

### 1310.3800 MANIPULATION OF LOCKING DEVICE.

Examine the assembly and determine a method and position of insertion of a tool through the window assembly from the outside so as to contact the locking device. Determine whether it is possible to insert any of the manipulation tools as described in part 1310.3100 and manipulate with them so as to unlock the window. Such window assemblies shall resist manipulation for a period of not less than five minutes.

**Statutory Authority:** *MS s 16B.59 to 16B.73*

### 1310.3900 PERFORMANCE REQUIREMENTS.

A window assembly shall fail these tests if at any time during or after the tests the assembly does not remain engaged, intact, and in the closed and lock position such as to preclude human entry.

**Statutory Authority:** *MS s 16B.59 to 16B.73*

### 1310.4000 REPORT.

The test report shall include:

A. name and address of the facility or laboratory performing these tests and issuing the report as well as the dates of testing and issuance of the report;

B. identification of the sample tested (e.g., name of manufacturer, model, and/or series number of product and other information as may be pertinent);

C. final assembly drawing(s) components list relative to type, size, location, and number of anchors, locking devices, and mounting screws used;

D. statement indicating that specimen either passed or failed these tests; and

E. statement that all test were conducted in accordance with these procedures.

**Statutory Authority:** *MS s 16B.59 to 16B.73*

# MINNESOTA RULES 1985

## 1310.9000 NONMANDATORY BUILDING SECURITY RULES

160

### 1310.9000 DIRECTIONS AND POINTS OF LOAD APPLICATION FOR TESTING OF HORIZONTAL SLIDING DOORS.

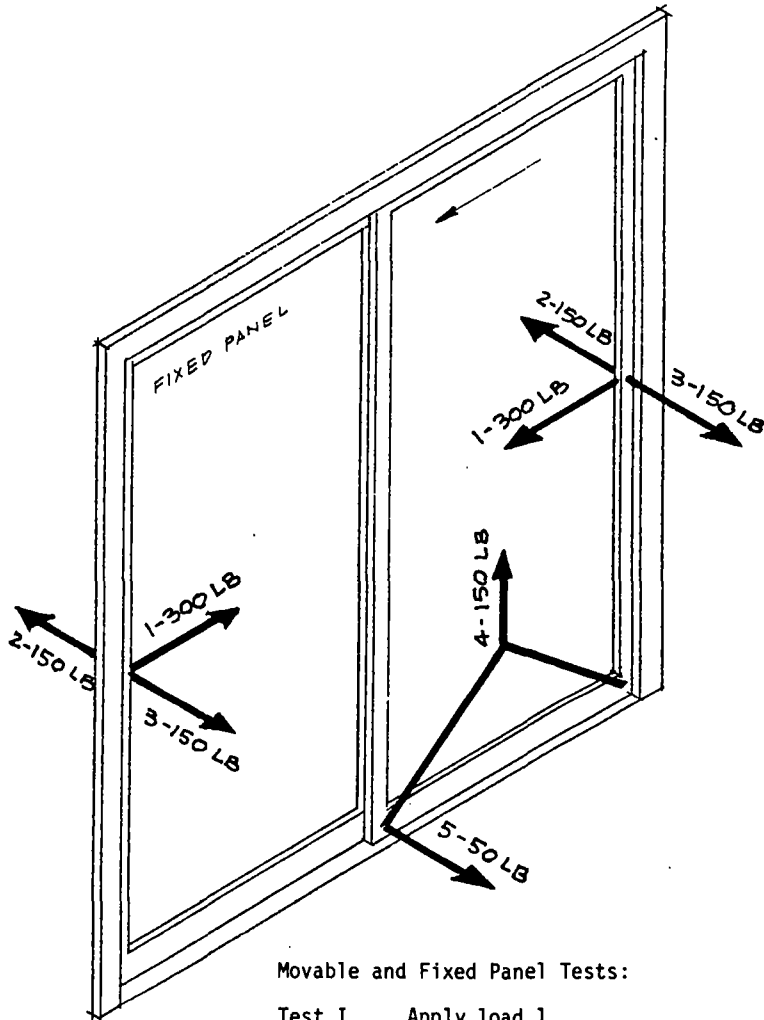

#### Movable and Fixed Panel Tests:

- |           |   |
|-----------|---|
| Test I    | Apply load 1  |
| Test II   | Apply loads 1 & 2   |
| Test III  | Apply loads 1 & 3   |
| Test IV   | Apply loads 4 & 1   |
| Test V    | Apply loads 4, 1 & 2  |
| Test VI   | Apply loads 4, 1 & 3  |
| Test VII  | Apply loads 4, 1, 3 & 5   |
| Test VIII | Manipulation Described  |
| Test IX   | For fixed panels repeat Tests I, II & III with the load point at the midpoint of the stile opposite the meeting stile of the door panel being tested. |

Statutory Authority: *MS s 16B.59 to 16B.73*

# MINNESOTA RULES 1985

161

## NONMANDATORY BUILDING SECURITY RULES 1310.9100

### 1310.9100 DIRECTIONS AND POINTS OF LOAD APPLICATION FOR TESTING OF TYPE A WINDOWS.

#### Sliding Sash Tests:

- Test I Apply load 1
- Test II Apply loads 1 & 2
- Test III Apply loads 1 & 3
- Test IV Apply loads 4 & 1
- Test V Apply loads 4, 1 & 2
- Test VI Apply loads 4, 1 & 3
- Test VII Apply loads 4, 1, 3 & 5
- Test VIII For fixed sashes locate the load point at the midpoint of the stile or rail opposite the meeting stile or rail of the sash under the test and apply loads as described in Tests I, II & III.

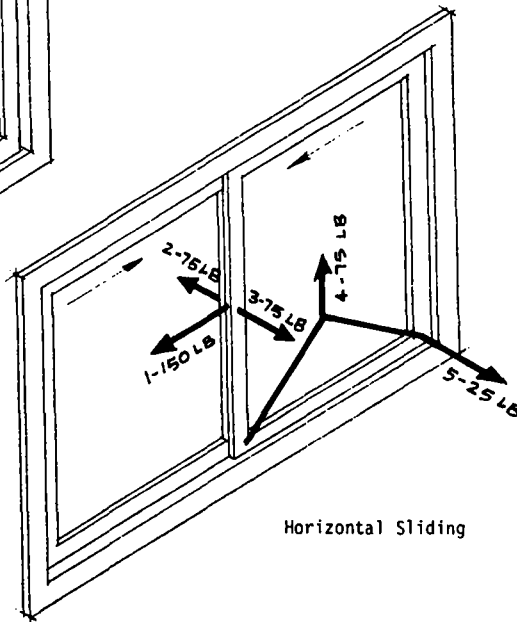
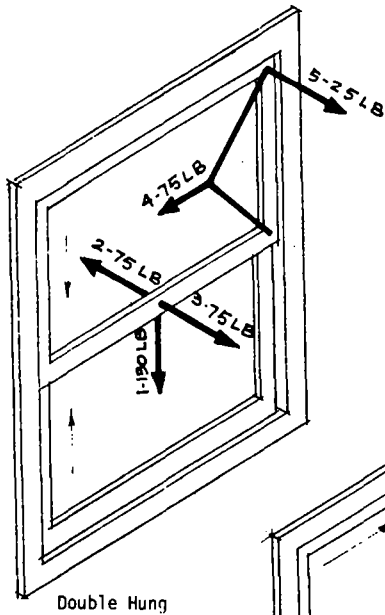

Statutory Authority: *MS s 16B.59 to 16B.73*

# MINNESOTA RULES 1985

## 1310.9200 NONMANDATORY BUILDING SECURITY RULES

162

### 1310.9200 DIRECTIONS AND POINTS OF LOAD APPLICATION FOR TESTING OF TYPES B AND C WINDOWS.

Tests for Hinged Sashes:

- |          |                        |
|----------|------------------------|
| Test I   | Apply load 1's         |
| Test II  | Apply load 1's and 2's |
| Test III | Apply load 3           |
| Test IV  | Apply load 3 and 2's   |

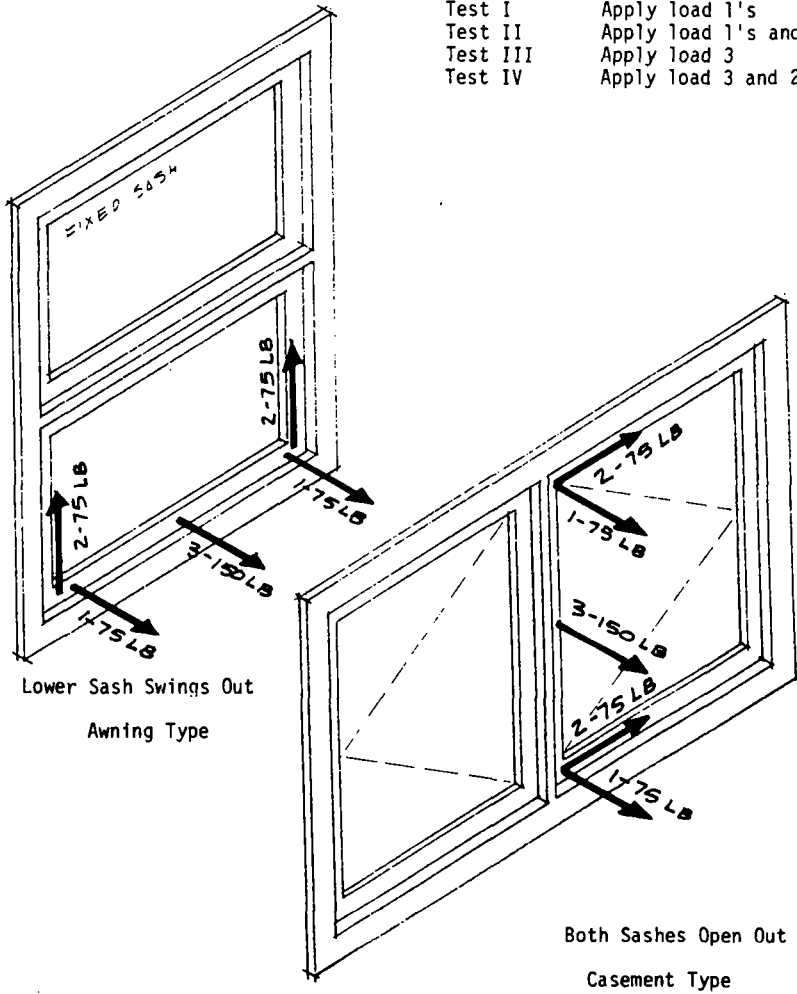

Statutory Authority: *MS s 16B.59 to 16B.73*

# MINNESOTA RULES 1985

163

NONMANDATORY BUILDING SECURITY RULES 1310.9300

## 1310.9300 DIRECTIONS AND POINTS OF LOAD APPLICATION FOR TESTING OF TYPE D WINDOWS.

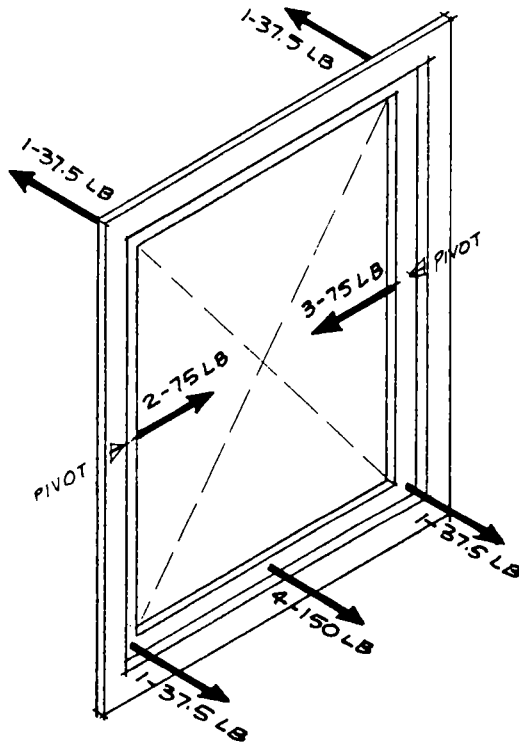

As shown, pivots are represented as triangles and sash pivots out from the bottom and in at the top.

### Pivoting Sash Tests:

Test I	Apply load 1's
Test II	Apply load 2
Test III	Apply load 3
Test IV	Apply load 4
Test V	Apply loads 4 & 2, then remove load 2 and apply loads 4 & 3.

Statutory Authority: *MS s 16B.59 to 16B.73*